

Applications

- Repeaters
- Mobile Infrastructure
- LTE / WCDMA
- General Purpose Wireless

Product Features

- 50–4000 MHz
- 15.3 dB Gain at 1.9 GHz
- 0.8 dB Noise Figure at 1.9 GHz
- <1.5:1 I/O VSWR (>14 dB I/O Return Loss)
- +34 dBm Output IP3
- +22.3 dBm P1dB
- 50 Ohm Cascadable Gain Block
- Unconditionally Stable
- High Input Power Capability
- Single Supply, 50 mA Current

General Description

The TQP3M9005 is a high linearity low noise gain block amplifier in a low-cost surface-mount package. At 1.9 GHz, the amplifier typically provides 15.3 dB gain, +34 dBm OIP3, and 0.8 dB Noise Figure while only drawing 50 mA current. The device is housed in a leadfree/green/RoHS-compliant industry-standard 16-pin 3x3 mm QFN package.

The TQP3M9005 has the benefit of having high linearity while also providing very low noise across a broad range of frequencies. This allows the device to be used in both receive and transmit chains for high performance systems. The amplifier is internally matched using a high performance E-pHEMT process and only requires an external RF choke and blocking/bypass capacitors for operation from a single supply. The internal active bias circuit also enables stable operation over bias and temperature variations.

The TQP3M9005 covers the 0.05–4 GHz frequency band and is targeted for wireless infrastructure or other applications requiring high linearity and/or low noise figure.

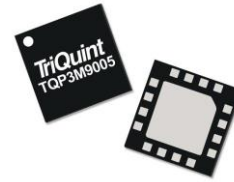

16-pin 3x3 mm QFN Package

Functional Block Diagram

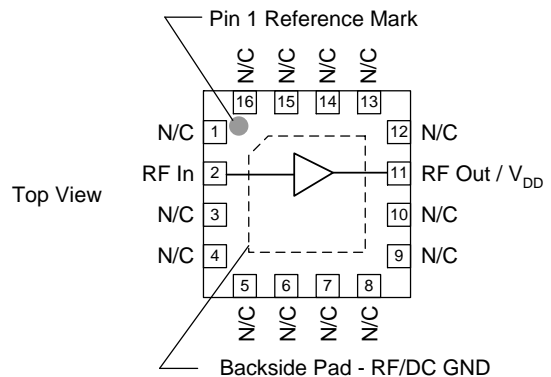

Pin Configuration

Pin No.	Label
2	RF In
11	RF Out / V _{DD}
All Other Pins	N/C
Backside Pad	RF/DC GND

Ordering Information

Part No.	Description
TQP3M9005	LNA Gain Block
TQP3M9005-PCB	0.5–4 GHz Evaluation Board

Standard T/R size = 2500 pieces on a 7" reel

Absolute Maximum Ratings

Parameter	Rating
Storage Temperature	-55 to 150 °C
RF Input Power, CW, 50Ω, T=25°C	+20 dBm
Device Voltage (V _{DD})	+7 V

Operation of this device outside the parameter ranges given above may cause permanent damage.

Recommended Operating Conditions

Parameter	Min	Typ	Max	Units
Device Voltage (V _{DD})	+3.0	+5.0	+5.25	V
T _{CASE}	-40		+105	°C
T _j for >10 ⁶ hours MTTF			+190	°C

Electrical specifications are measured at specified test conditions. Specifications are not guaranteed over all recommended operating conditions.

Electrical Specifications

Test conditions unless otherwise noted: V_{DD}=+5 V, Temp=+25 °C, 50 Ω system

Parameter	Conditions	Min	Typ	Max	Units
Operational Frequency Range		50		4000	MHz
Test Frequency			1900		MHz
Gain		13.9	15.3	16.9	dB
Input Return Loss			12		dB
Output Return Loss			14		dB
Output P1dB			+22.3		dBm
Output IP3	P _{out} =+2 dBm/tone, Δf=1 MHz	+30	+34		dBm
Noise Figure			0.8		dB
Current, I _{DD}		35	50	68	mA
Thermal Resistance, θ _{jc}	Junction to case		76.8		°C/W

Device Characterization Data

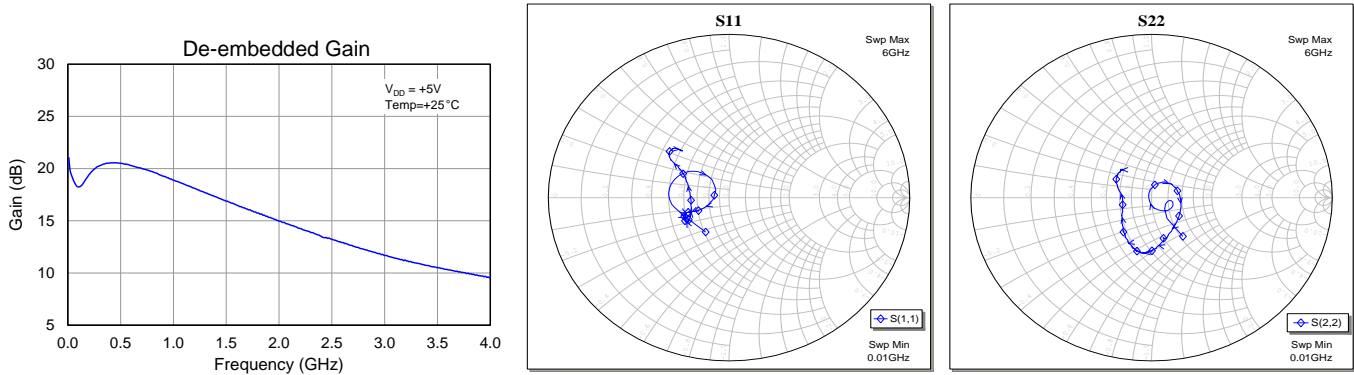

S-Parameters

Test Conditions: $V_{DD} = +5V$, $I_{DD} = 50mA$, $T = +25^{\circ}C$, 50 ohm system, calibrated to device leads

Freq (MHz)	S11 (dB)	S11 (ang)	S21 (dB)	S21 (ang)	S12 (dB)	S12 (ang)	S22 (dB)	S22 (ang)
50	-10.60	-165.03	18.97	169.37	-28.21	3.31	-20.93	-16.62
100	-9.49	175.55	18.25	174.21	-28.93	7.02	-18.17	-16.66
200	-10.87	147.24	19.40	177.58	-27.58	15.94	-20.08	-53.04
400	-17.37	131.91	20.53	160.55	-26.03	13.26	-35.69	161.57
800	-19.08	-162.95	19.71	130.50	-25.55	10.38	-18.59	54.50
1000	-16.31	-155.70	18.89	118.70	-25.42	10.64	-17.17	35.91
1200	-14.56	-155.11	18.10	108.64	-25.21	11.47	-16.62	16.88
1500	-13.21	-157.04	16.88	94.87	-24.85	13.11	-15.65	-9.94
1900	-12.17	-158.41	15.32	79.10	-24.31	13.69	-14.06	-43.51
2000	-11.91	-158.36	14.97	75.77	-24.10	13.71	-13.59	-50.29
2200	-11.68	-157.13	14.26	68.76	-23.87	13.48	-12.60	-62.64
2500	-11.30	-155.40	13.24	59.49	-23.35	12.97	-11.28	-75.63
2600	-11.23	-154.34	12.92	56.53	-23.20	12.81	-10.96	-79.40
3000	-11.03	-150.07	11.67	45.14	-22.54	11.37	-9.77	-89.57
3500	-11.47	-147.07	10.53	31.94	-21.61	7.86	-9.39	-100.67
4000	-13.13	-160.94	9.56	16.71	-20.66	1.90	-10.56	-116.49

TQP3M9005-PCB Evaluation Board

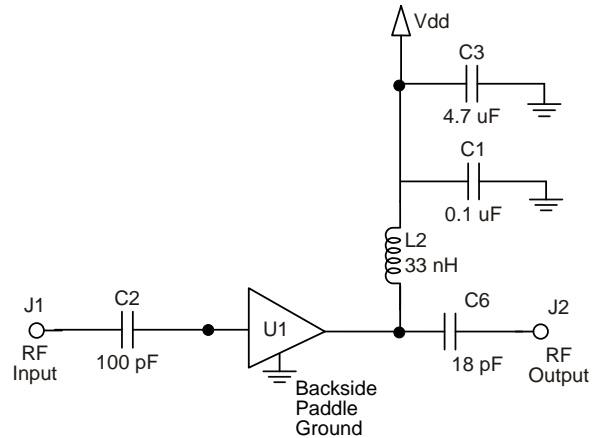
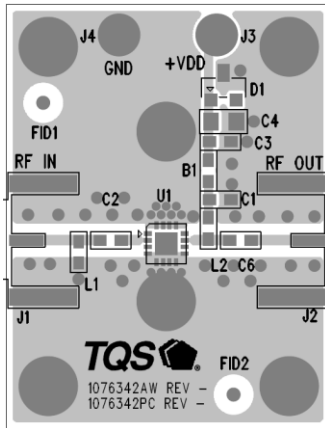

Notes:

1. See PC Board Layout in Applications section for more information.
2. Components shown on the silkscreen but not on the schematic are not used.
3. B1 (0 Ω jumper) may be replaced with copper trace in the target application layout.
4. All components are of 0603 size unless stated on the schematic.
5. C6 and L2 value are critical for linearity performance.

Bill of Material – TQP3M9005-PCB

Reference Des.	Value	Description	Manufacturer	Part Number
U1	n/a	High Linearity LNA Gain Block	Qorvo	TQP3M9005
C2	100 pF	Cap, Chip, 0603, 50V, NPO, 5%	various	
C6	18 pF	Cap, Chip, 0603, 50V, NPO, 5%	various	
C1	0.1 uF	Cap, Chip, 0603, 16V, X7R, 10%	various	
L2	33 nH	Ind, Chip, 0603, 5%	various	
C3	4.7 uF	Cap, Chip, 0603, 6.3V, X5R, 20%	various	
B1	0 Ω	Res, Chip, 0603, 1/16W, 5%	various	
L1, D1, C4	Do Not Place		various	

Typical Performance – TQP3M9005-PCB

Test conditions unless otherwise noted: $V_{DD}=+5V$, $I_{DD}=50mA$, $Temp=+25^{\circ}C$, 50 Ω system.

Parameter	Typical Value					Units
	500	900	1900	2100	2600	
Frequency	500	900	1900	2100	2600	MHz
Gain	20.6	19.4	15.3	14.5	12.8	dB
Input Return Loss	19	16	12	11	11	dB
Output Return Loss	17	16	14	13	11	dB
Output P1dB	+22.2	+22.2	+22.3	+22.5	+22.5	dBm
OIP3	+32	+32.9	+34.0	+33.6	+33.8	dBm
Noise figure	1.0	0.9	0.8	0.85	1.1	dB

Notes:

1. OIP3 measured with two tones at an output power of +2 dBm / tone separated by 1 MHz.
2. Noise figure data shown in the table above is corrected for PCB losses of 0.11 dB at 0.5 GHz, board loss of 0.08 dB at 0.9 GHz, board loss of 0.13 dB at 1.9 GHz, board loss of 0.14 dB at 2.1 GHz and board loss of 0.17dB at 2.6 GHz.

Performance Plots – TQP3M9005-PCB

Test conditions unless otherwise noted: $V_{DD}=+5\text{ V}$, $I_{DD}=50\text{ mA}$, $\text{Temp}=+25\text{ }^{\circ}\text{C}$, $50\ \Omega$ system.

Noise figure plot has been corrected for evaluation board loss of 0.13 dB at 1.9 GHz.

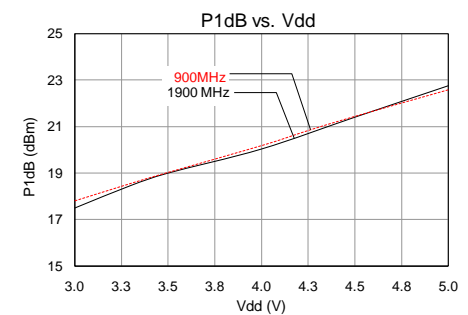
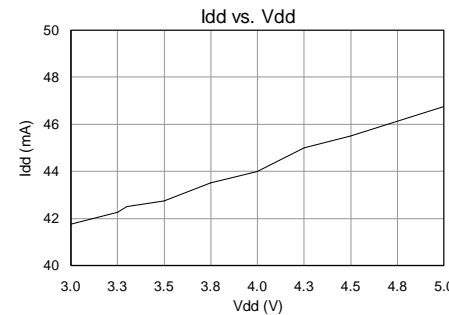
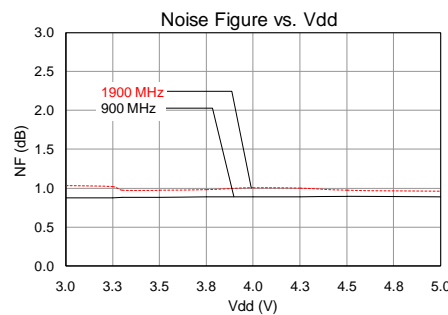
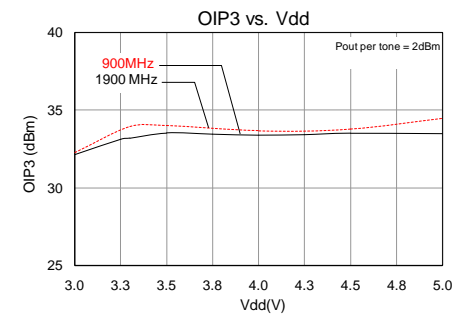
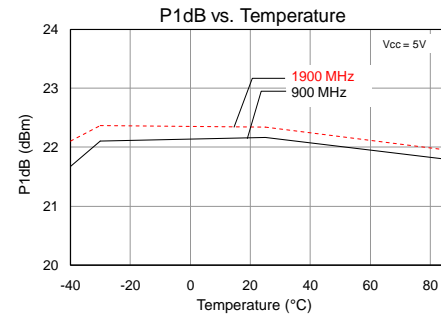
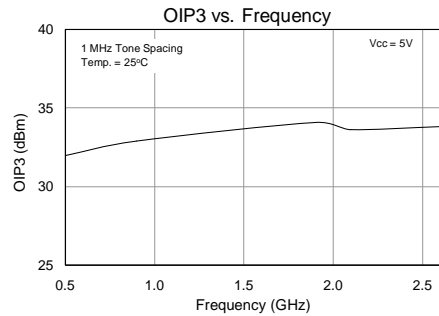
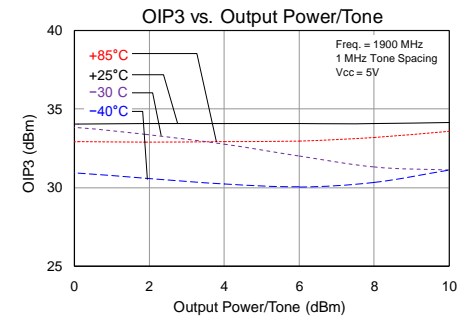
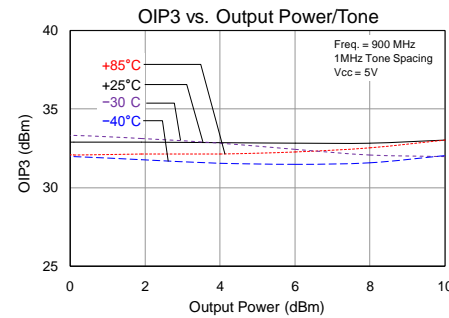
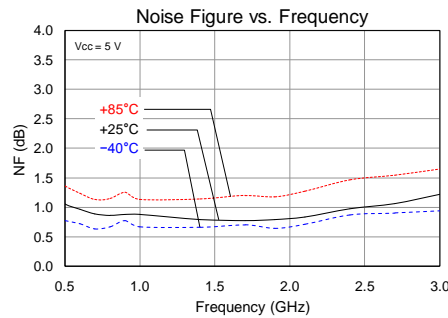
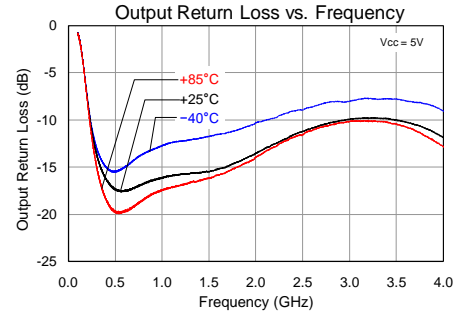
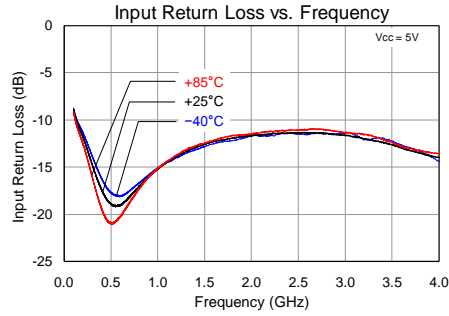
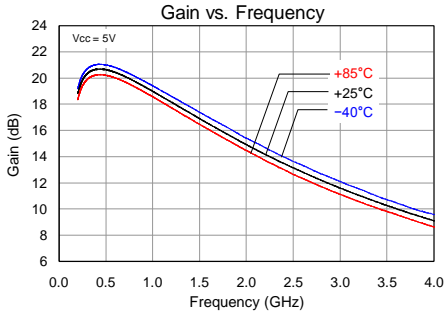

TQP3M9005 Low Frequency Performance

Test conditions unless otherwise noted: $V_{DD}=+5V$, $I_{DD}=50mA$, $Temp=+25^{\circ}C$, 50Ω system.

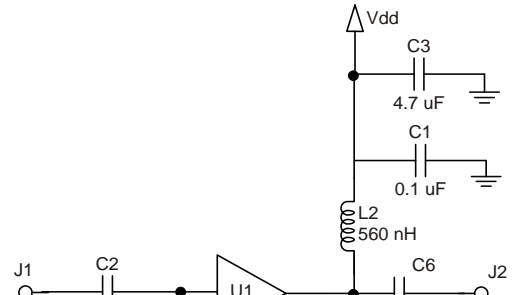
Parameter	Typical Value			Units	Schematic
Frequency	50	100	200	MHz	
Gain	18.9	18.3	19.4	dB	
Input Return Loss	10	9.7	11.5	dB	
Output Return Loss	16	18	22	dB	
Output P1dB	+18.7	+19.45	+21.4	dBm	
OIP3	+29.2	+29.7	+27.5	dBm	
Noise figure	6.6	5.1	2.9	dB	

Notes:

- OIP3 measured with two tones at an output power of +2 dBm / tone separated by 1 MHz.

Low Frequency Performance Plots

Test conditions unless otherwise noted: $V_{DD}=+5V$, $I_{DD}=50mA$, $Temp=+25^{\circ}C$, 50Ω system.

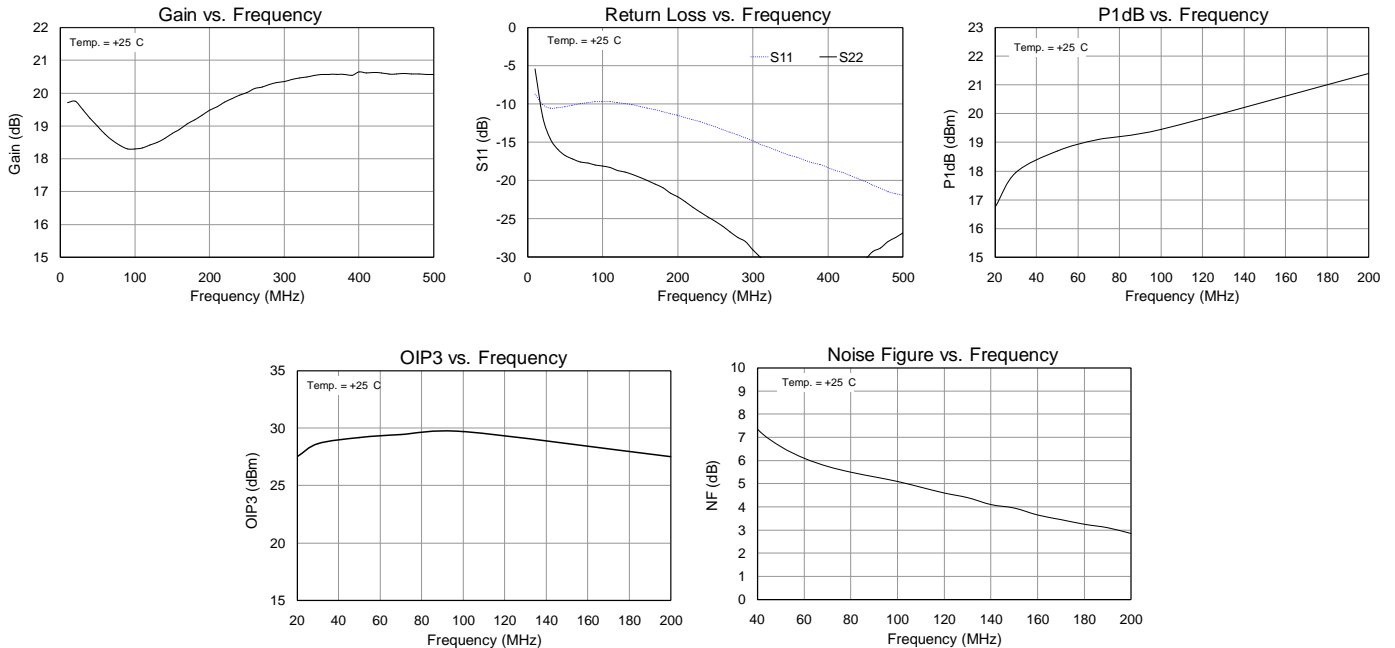

Pin Configuration and Description

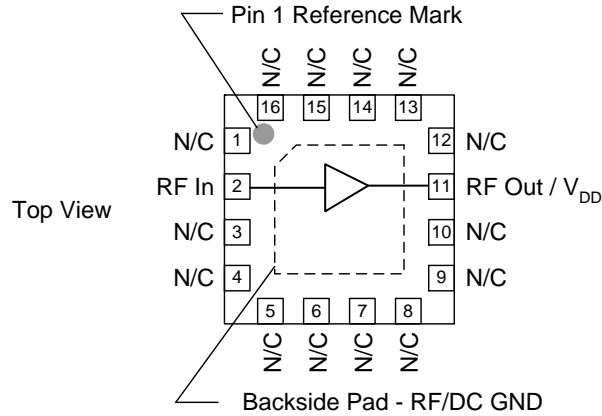

Pin No.	Label	Description
2	RF Input	Input, matched to 50 ohms. External DC Block is required.
11	Vdd / RFout	Output, matched to 50 ohms, External DC Block is required and supply voltage.
All other pins	N/C	No internal connection. Provide grounded pads on PCB land pattern for optimal isolation and mounting integrity..
Backside Pad	RF/DC GND	Backside Pad. Multiple vias should be employed to minimize inductance and thermal resistance; see PCB mounting pattern in Mechanical Information section.

Evaluation Board PCB Information

Qorvo PCB 1076342 Material and Stack-up

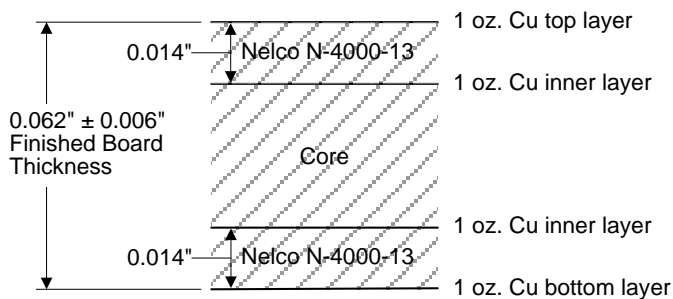

50 ohm line dimensions: width = .029", spacing = .035"

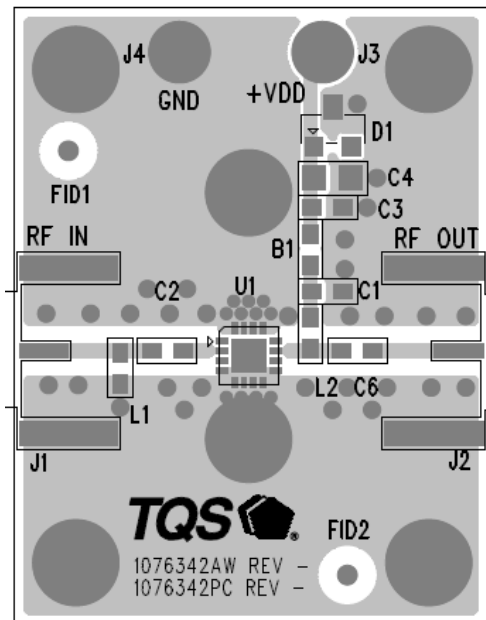

Package Marking and Dimensions

Package Marking:
 Part number – 9005
 Year, week code - YYWW
 Assembly code – aXXXX

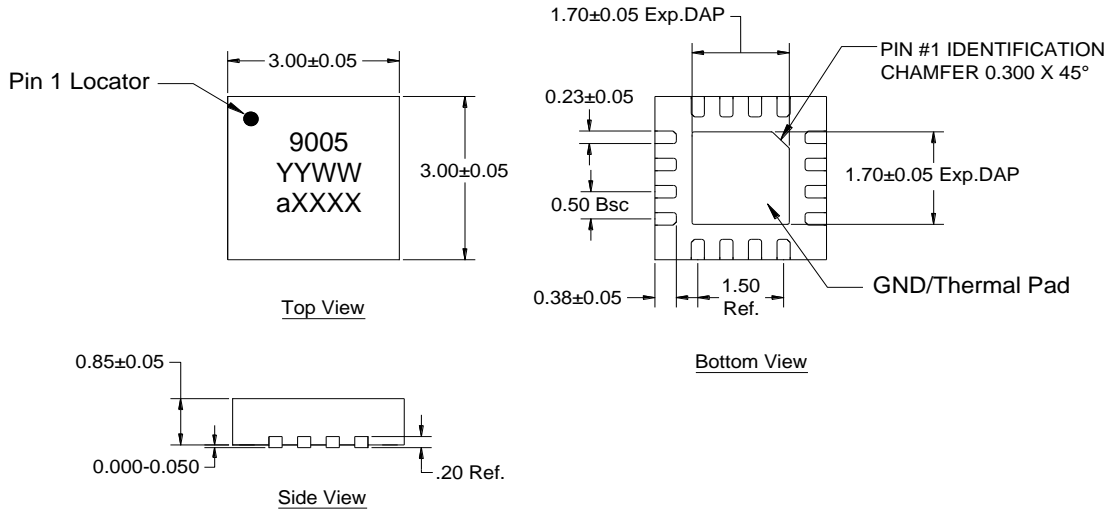

- Notes:
1. All dimensions are in millimeters. Angles are in degrees.
 2. Dimension and tolerance formats conform to ASME Y14.4M-1994.
 3. The terminal #1 identifier and terminal numbering conform to JESD 95-1 SPP-012.
 4. Contact plating: Annealed Matte Tin

PCB Mounting Pattern

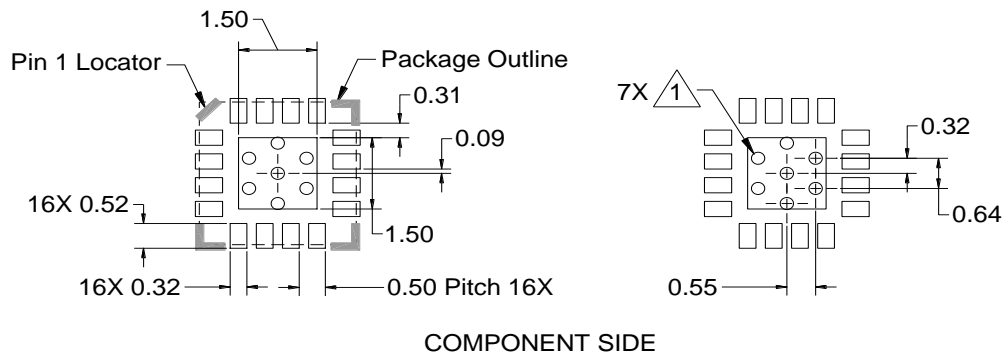

- Notes:
1. All dimensions are in millimeters. Angles are in degrees.
 2. Use 1 oz. copper minimum for top and bottom layer metal.
 3. Vias are required under the backside paddle of this device for proper RF/DC grounding and thermal dissipation.
 4. We recommend a 0.35mm (#80/.0135") diameter bit for drilling via holes and a final plated thru diameter of 0.25 mm (0.10").
 5. Ensure good package backside paddle solder attach for best electrical and thermal performance.

Product Compliance Information

ESD Sensitivity Ratings



Caution! ESD-Sensitive Device

ESD Rating: Class 1A
Value: $\geq 250\text{V}$ to $< 500\text{V}$
Test: Human Body Model (HBM)
Standard: JEDEC Standard JS-001-2012

ESD Rating: Class C3
Value: $\geq 1000\text{V}$
Test: Charged Device Model (CDM)
Standard: JEDEC Standard JESD22-C101F

MSL Rating

MSL Rating: Level 1
Test: 260°C convection reflow
Standard: JEDEC Standard IPC/JEDEC J-STD-020

Solderability

Compatible with both lead-free (260°C maximum reflow temperature) and tin/lead (245°C maximum reflow temperature) soldering processes.

Contact plating: Annealed Matte Tin

RoHS Compliance

This part is compliant with EU 2002/95/EC RoHS directive (Restrictions on the Use of Certain Hazardous Substances in Electrical and Electronic Equipment).

This product also has the following attributes:

- Lead Free
- Halogen Free (Chlorine, Bromine)
- Antimony Free
- TBBP-A ($\text{C}_{15}\text{H}_{12}\text{Br}_4\text{O}_2$) Free
- PFOS Free
- SVHC Free

Contact Information

For the latest specifications, additional product information, worldwide sales and distribution locations, and information about Qorvo:

Web: www.qorvo.com Tel: +1.503.615.9000
Email: info-sales@qorvo.com Fax: +1.503.615.8902

For technical questions and application information:

Email: sjcappliations.engineering@qorvo.com

Important Notice

The information contained herein is believed to be reliable. TriQuint makes no warranties regarding the information contained herein. TriQuint assumes no responsibility or liability whatsoever for any of the information contained herein. TriQuint assumes no responsibility or liability whatsoever for the use of the information contained herein. The information contained herein is provided "AS IS, WHERE IS" and with all faults, and the entire risk associated with such information is entirely with the user. All information contained herein is subject to change without notice. Customers should obtain and verify the latest relevant information before placing orders for TriQuint products. The information contained herein or any use of such information does not grant, explicitly or implicitly, to any party any patent rights, licenses, or any other intellectual property rights, whether with regard to such information itself or anything described by such information.

TriQuint products are not warranted or authorized for use as critical components in medical, life-saving, or life-sustaining applications, or other applications where a failure would reasonably be expected to cause severe personal injury or death.

Компания «Life Electronics» занимается поставками электронных компонентов импортного и отечественного производства от производителей и со складов крупных дистрибьюторов Европы, Америки и Азии.

С конца 2013 года компания активно расширяет линейку поставок компонентов по направлению коаксиальный кабель, кварцевые генераторы и конденсаторы (керамические, пленочные, электролитические), за счёт заключения дистрибьюторских договоров

Мы предлагаем:

- Конкурентоспособные цены и скидки постоянным клиентам.
- Специальные условия для постоянных клиентов.
- Подбор аналогов.
- Поставку компонентов в любых объемах, удовлетворяющих вашим потребностям.
- Приемлемые сроки поставки, возможна ускоренная поставка.
- Доставку товара в любую точку России и стран СНГ.
- Комплексную поставку.
- Работу по проектам и поставку образцов.
- Формирование склада под заказчика.
- Сертификаты соответствия на поставляемую продукцию (по желанию клиента).
- Тестирование поставляемой продукции.
- Поставку компонентов, требующих военную и космическую приемку.
- Входной контроль качества.
- Наличие сертификата ISO.

В составе нашей компании организован Конструкторский отдел, призванный помогать разработчикам, и инженерам.

Конструкторский отдел помогает осуществить:

- Регистрацию проекта у производителя компонентов.
- Техническую поддержку проекта.
- Защиту от снятия компонента с производства.
- Оценку стоимости проекта по компонентам.
- Изготовление тестовой платы монтаж и пусконаладочные работы.



Тел: +7 (812) 336 43 04 (многоканальный)

Email: org@lifeelectronics.ru