

High Power Ka-Band Absorptive SPDT Switch

TGS4304

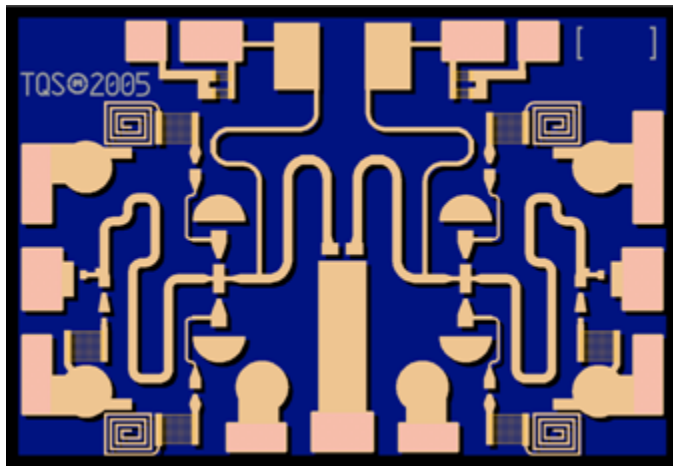

Key Features and Performance

- 32 - 40 GHz Frequency Range
- > 33 dBm Input P1dB @ $V_C = +10V$
- On Chip Biasing Resistors
- On Chip DC Blocks
- < 1.0 dB Midband Insertion Loss
- < 4ns Switching Speed
- VPIN Technology
- Chip Dimensions:
1.58 x 1.10 x 0.10 mm
(0.043 x 0.062 x 0.004 inches)

Description

The TriQuint TGS4304 is a GaAs absorptive single-pole, double-throw (SPDT) PIN monolithic switch designed to operate over the Ka-Band frequency range. This switch maintains a low insertion loss with high power handling of 33dBm or greater input P1dB at $V_C = +10V$. These advantages, along with the small size of the chip, make the TGS4304 ideal for use in communication and transmit/receive applications.

The TGS4304 is 100% DC & RF tested on-wafer to ensure performance compliance.

Lead free and RoHS compliant.

Primary Applications

- Ka-Band Transmit / Receive
- Point-to-Point Radio
- Point-to-Multipoint Radio

Measured Data

$V_A = +5V$, $I_A \approx 0mA$, $V_B = -4V$, $I_B = 30mA$

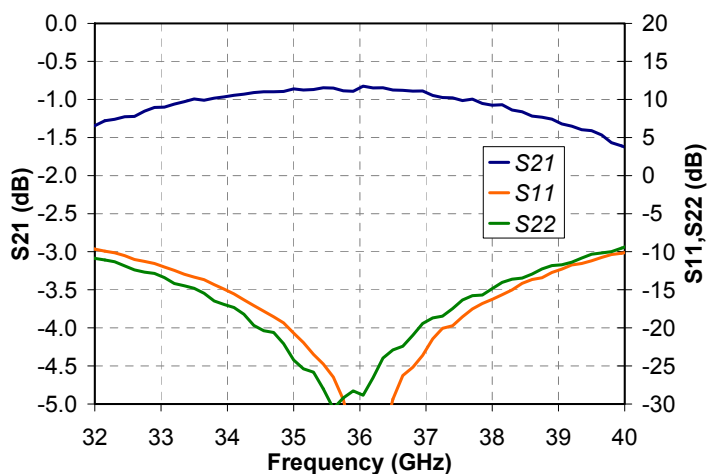

Note: This device is early in the characterization process prior to finalizing all electrical test specifications. Specifications are subject to change without notice.

**TABLE I
MAXIMUM RATINGS**

Symbol	Parameter 1/	Value	Notes
V _C	Control Voltage	-5V to +25V	2/
I _C	Control Current	34 mA	<u>2/</u>
P _{IN}	Input Continuous Wave Power	35 dBm	
T _M	Mounting Temperature (30 Seconds)	320 °C	
T _{STG}	Storage Temperature	-65 to 150 °C	

1/ These ratings represent the maximum operable values for this device.

2/ V_C and I_C are per bias pad.

3/ Operation above 30dBm requires control voltages above +7.5V.

**TABLE II
RF CHARACTERIZATION TABLE
(T_A = 25°C, Nominal)
(V_A = +5V, I_A = 0mA, V_B = -4V, I_B = 30mA)**

Symbol	Parameter	Test Conditions	Typ	Units	Notes
IL	Insertion Loss	F = 32 – 34 GHz F = 34 – 37 GHz F = 37 – 40 GHz	1.3 0.9 1.3	dB	
RL	Return Loss	F = 32 – 40 GHz	10	dB	
P1dB	Output Power @ 1dB Gain Compression	V _C = +5 V V _C = +7.5 V V _C = +10 V V _C = +20 V	31 33 34 34.5	dBm	<u>1/</u>

Note: Table II Lists the RF Characteristics of typical devices as determined by fixtured measurements.

1/ Frequency = 30GHz

**TABLE III
TRUTH TABLE**

Selected RF Output	V _A	V _B
RF Out A	≥ +5V @ ~0mA	-4V @ 30mA
RF Out B	-4V @ 30mA	≥ +5V @ ~0mA

Selected RF Output	I _A	I _B
RF Out A	≥ +5V @ ~0mA	30mA
RF Out B	30mA	≥ +5V @ ~0mA

Operation at RF power levels >30 dBm requires increasing the positive voltage level to put a larger reverse bias on the diodes while the negative voltage level remains at -4V with a current of approximately 30mA. If you are using -5V, use alternate assembly with off chip resistors.

Bond pads IA and IB bypass the on-chip series resistors to allow adjustment of the current to the diodes in their forward biased state.

**Measured Performance
On State**

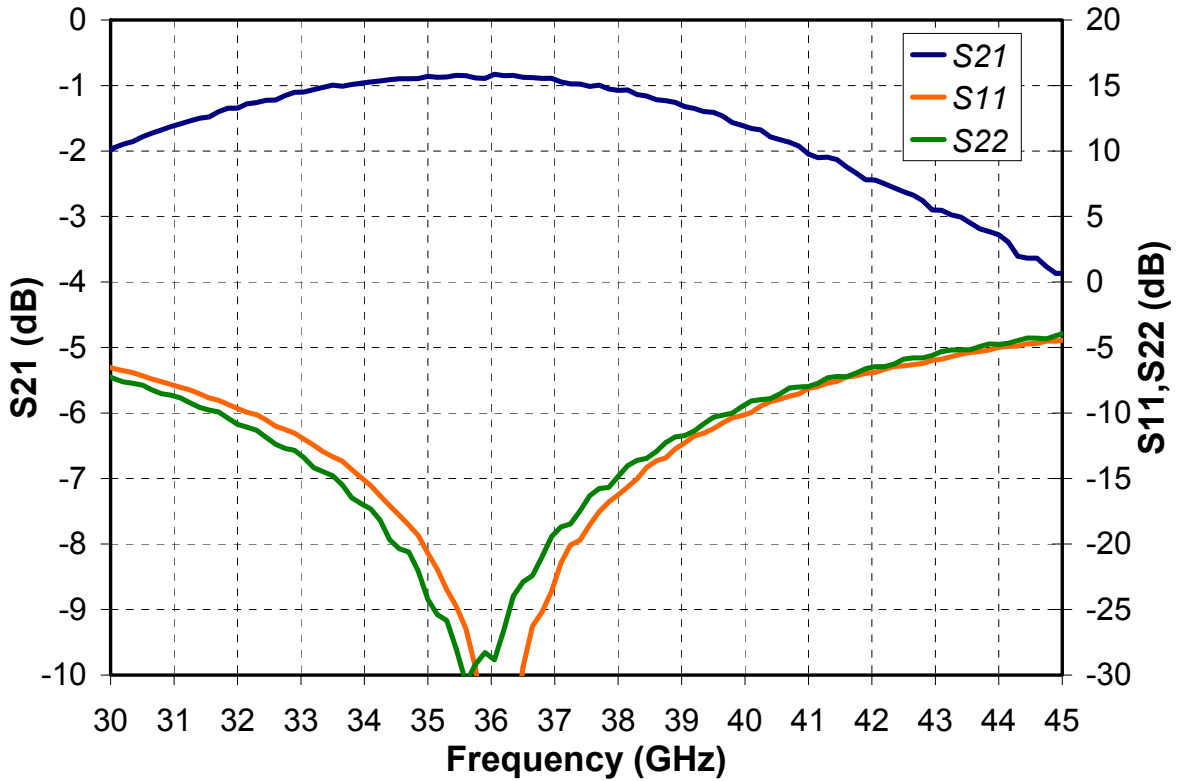

Off State

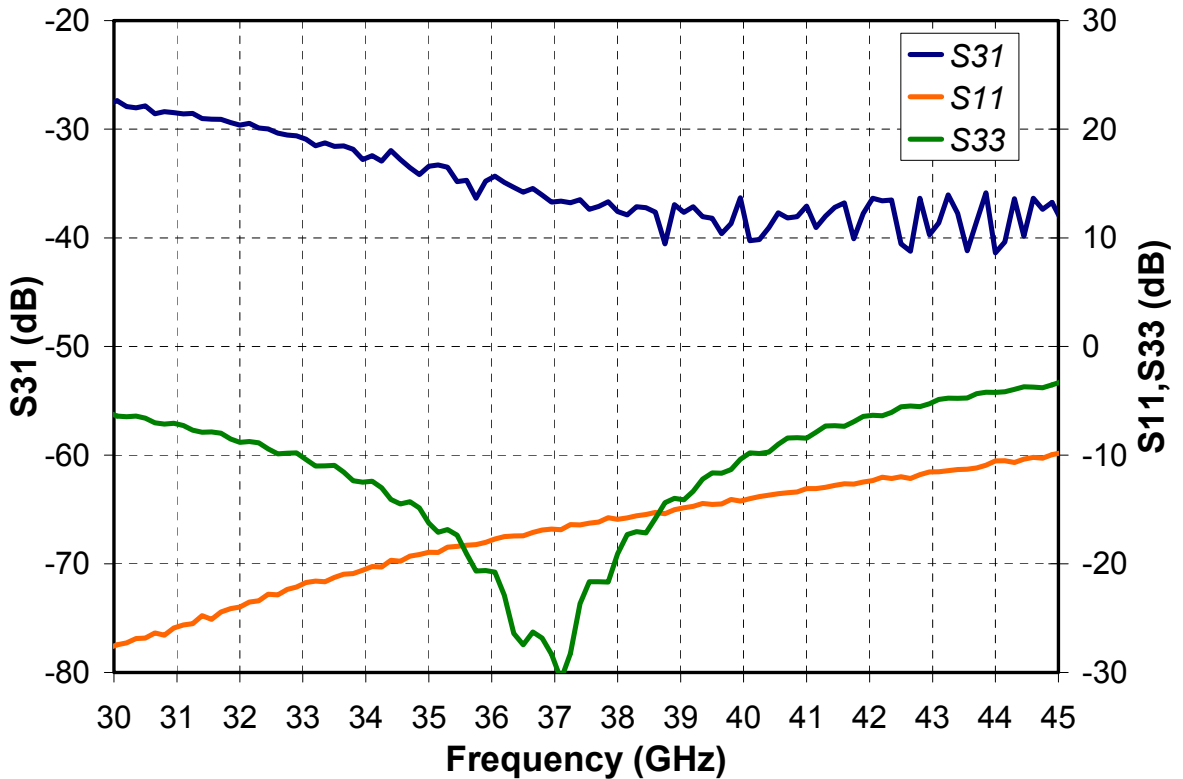

Measured Performance 30 GHz

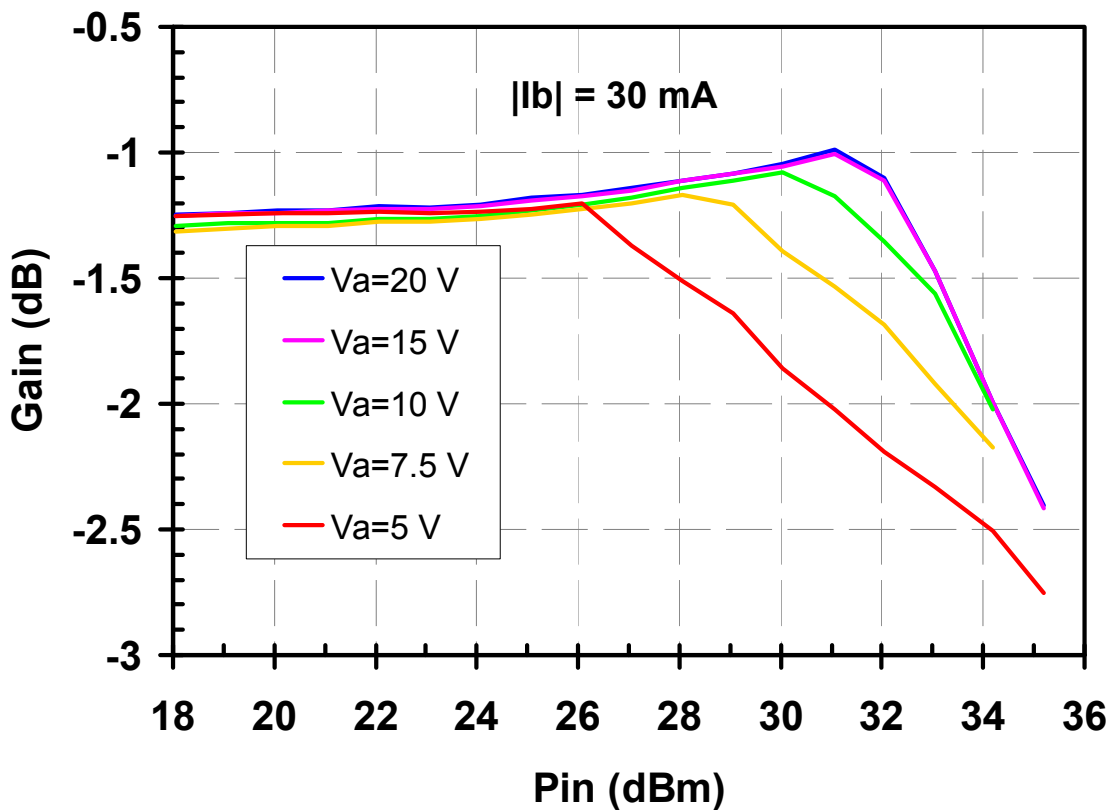

Measured Performance On State

Measurements include connector / fixture losses of ~ 1dB

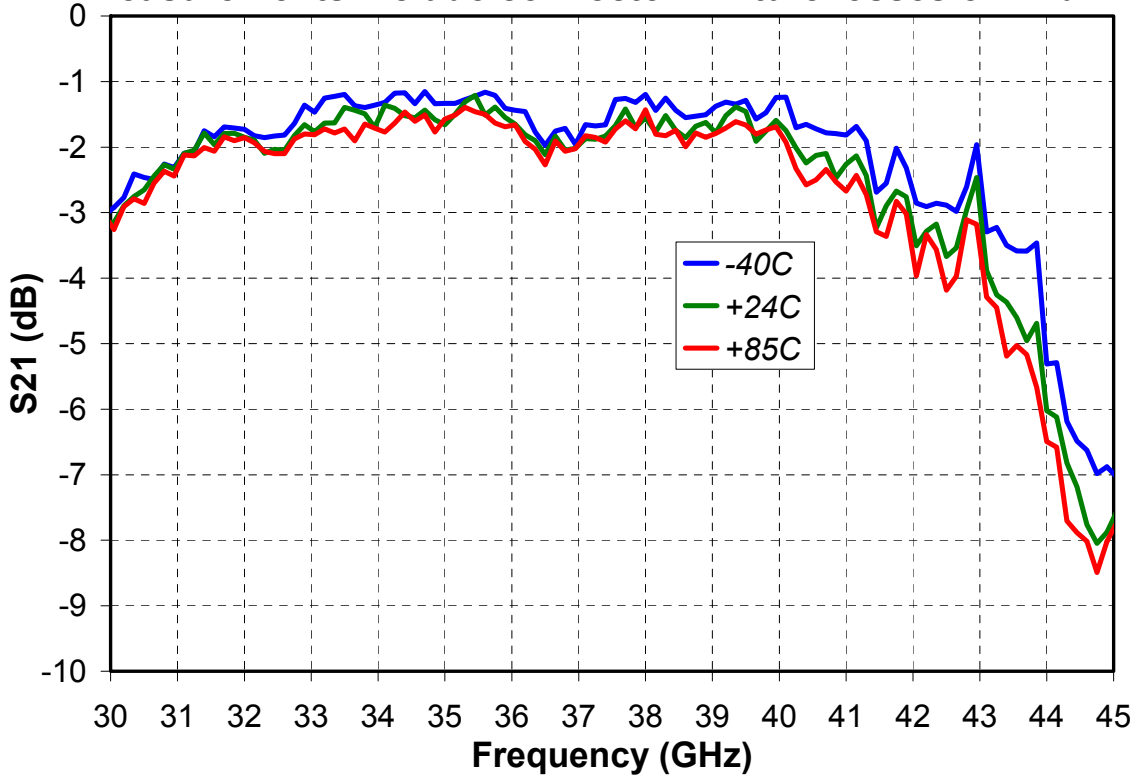

Off State

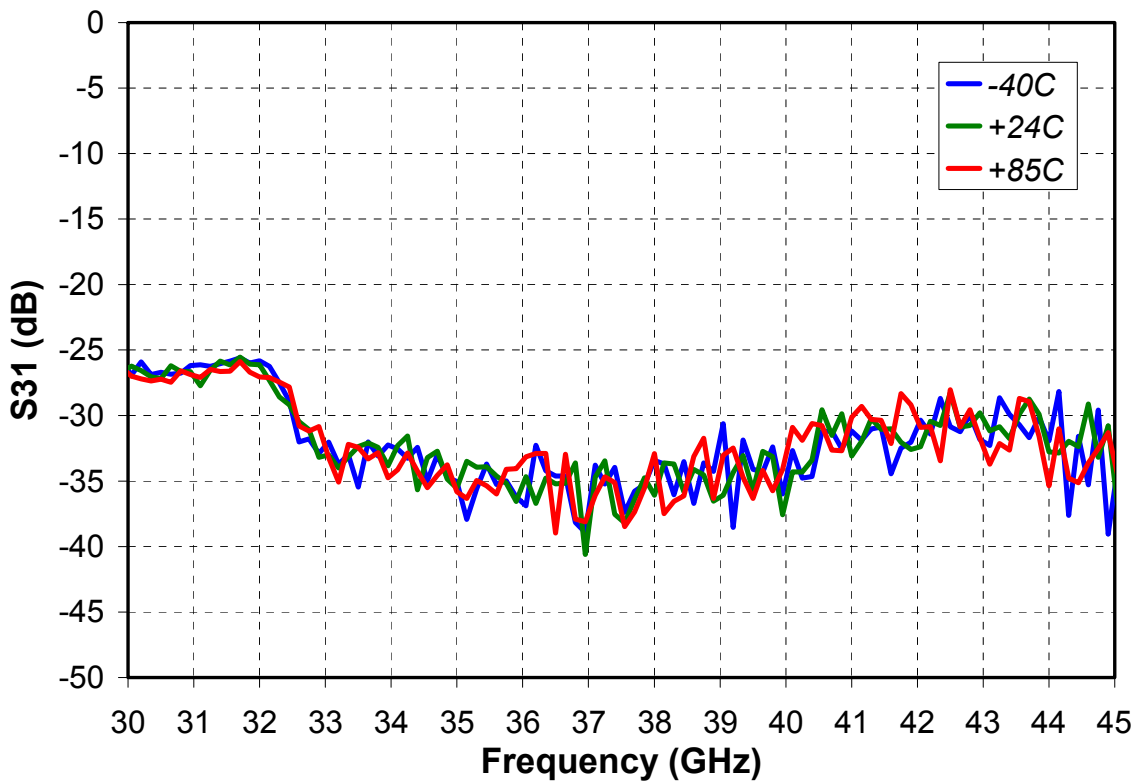

Mechanical Drawing

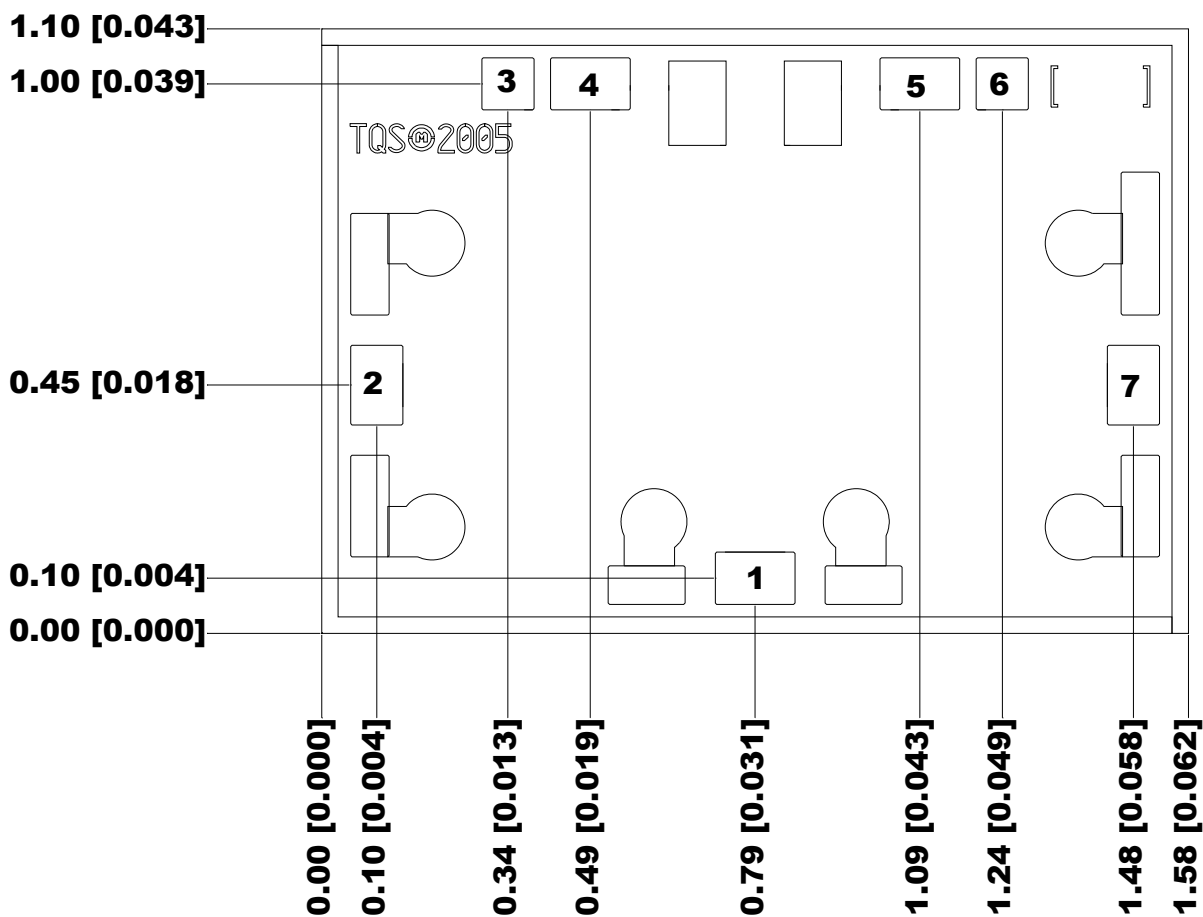

Units: millimeters (inches)

Thickness: 0.100 (0.004)

Chip edge to bond pad dimensions are shown to center of bond pad

Chip size tolerance: +/- 0.051 (0.002)

GND IS BACKSIDE OF MMIC

Bond Pad #1	(RF In)	0.15 x 0.10 (0.006 x 0.004)
Bond Pad #2	(RF Out A)	0.10 x 0.15 (0.004 x 0.006)
Bond Pad #3	(VA)	0.10 x 0.10 (0.004 x 0.004)
Bond Pad #4	(IA)	0.15 x 0.10 (0.006 x 0.004)
Bond Pad #5	(IB)	0.15 x 0.10 (0.006 x 0.004)
Bond Pad #6	(VB)	0.10 x 0.10 (0.004 x 0.004)
Bond Pad #7	(RF Out B)	0.10 x 0.15 (0.004 x 0.006)

Chip Assembly & Bonding Diagram

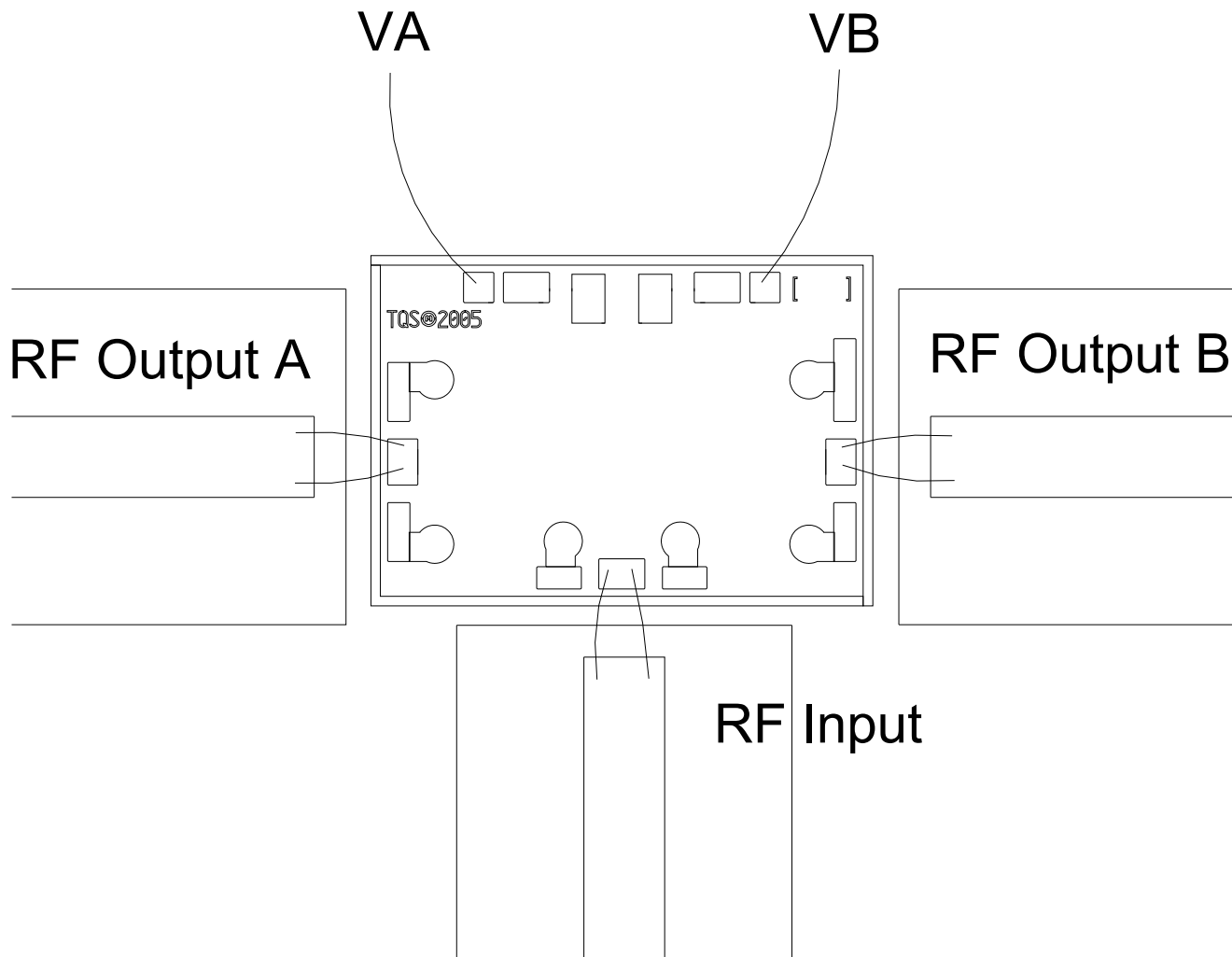

GaAs MMIC devices are susceptible to damage from Electrostatic Discharge. Proper precautions should be observed during handling, assembly and test.

Alternate Chip Assembly & Bonding Diagram TGS4304

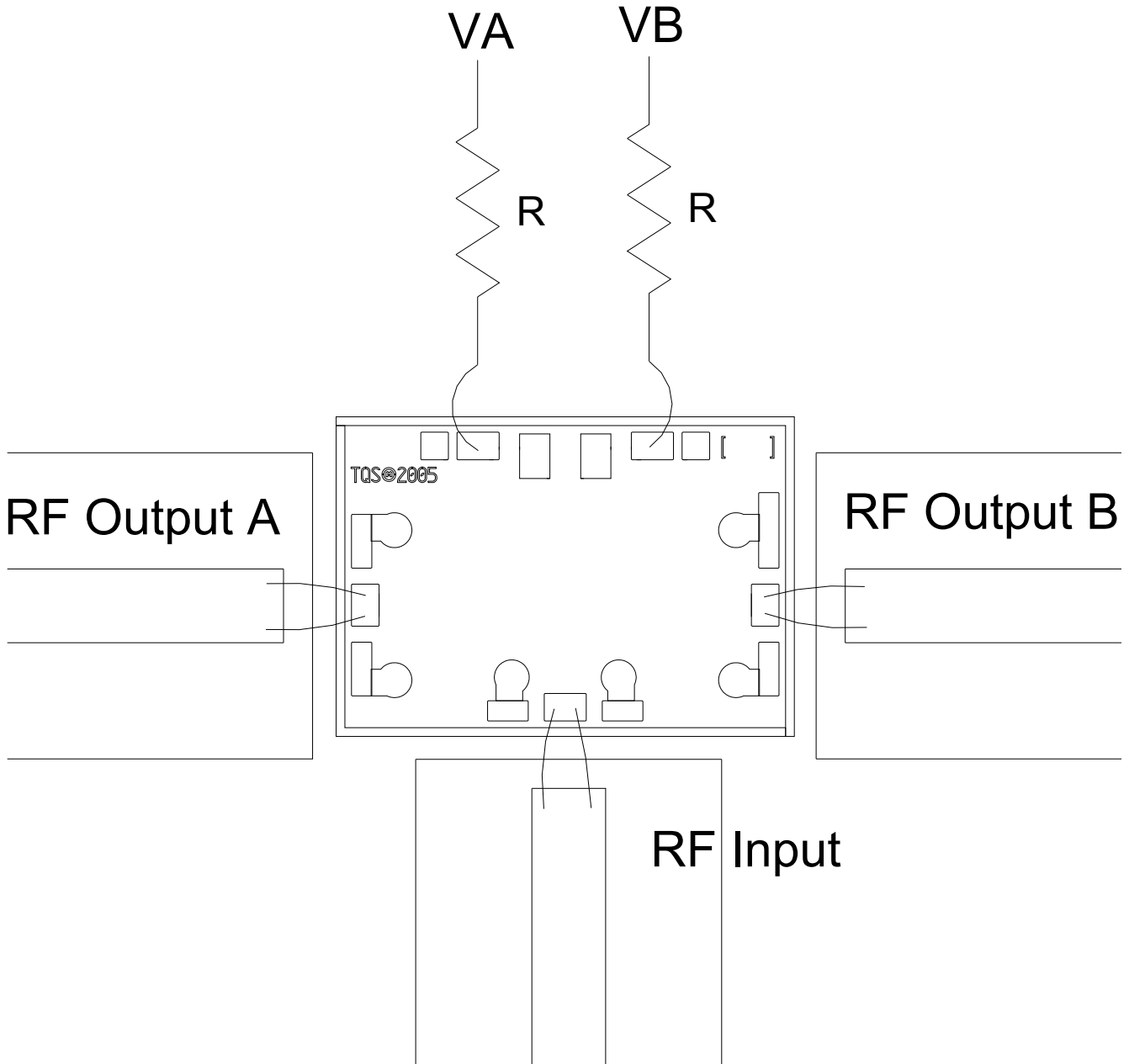

**TABLE IV
BIAS RESISTOR VALUES**

Maximum Negative Bias Voltage	R
-5V	33 Ohms
-7.5V	117 Ohms
-10V	200 Ohms
-15V	367 Ohms
-20V	533 Ohms

Assembly Process Notes

Reflow process assembly notes:

- Use AuSn (80/20) solder with limited exposure to temperatures at or above 300°C. (30 seconds maximum)
- An alloy station or conveyor furnace with reducing atmosphere should be used.
- No fluxes should be utilized.
- Coefficient of thermal expansion matching is critical for long-term reliability.
- Devices must be stored in a dry nitrogen atmosphere.

Component placement and adhesive attachment assembly notes:

- Vacuum pencils and/or vacuum collets are the preferred method of pick up.
- Air bridges must be avoided during placement.
- The force impact is critical during auto placement.
- Organic attachment can be used in low-power applications.
- Curing should be done in a convection oven; proper exhaust is a safety concern.
- Microwave or radiant curing should not be used because of differential heating.
- Coefficient of thermal expansion matching is critical.

Interconnect process assembly notes:

- Thermosonic ball bonding is the preferred interconnect technique.
- Force, time, and ultrasonics are critical parameters.
- Aluminum wire should not be used.
- Maximum stage temperature is 200°C.

GaAs MMIC devices are susceptible to damage from Electrostatic Discharge. Proper precautions should be observed during handling, assembly and test.

Компания «Life Electronics» занимается поставками электронных компонентов импортного и отечественного производства от производителей и со складов крупных дистрибьюторов Европы, Америки и Азии.

С конца 2013 года компания активно расширяет линейку поставок компонентов по направлению коаксиальный кабель, кварцевые генераторы и конденсаторы (керамические, пленочные, электролитические), за счёт заключения дистрибьюторских договоров

Мы предлагаем:

- Конкурентоспособные цены и скидки постоянным клиентам.
- Специальные условия для постоянных клиентов.
- Подбор аналогов.
- Поставку компонентов в любых объемах, удовлетворяющих вашим потребностям.
- Приемлемые сроки поставки, возможна ускоренная поставка.
- Доставку товара в любую точку России и стран СНГ.
- Комплексную поставку.
- Работу по проектам и поставку образцов.
- Формирование склада под заказчика.
- Сертификаты соответствия на поставляемую продукцию (по желанию клиента).
- Тестирование поставляемой продукции.
- Поставку компонентов, требующих военную и космическую приемку.
- Входной контроль качества.
- Наличие сертификата ISO.

В составе нашей компании организован Конструкторский отдел, призванный помогать разработчикам, и инженерам.

Конструкторский отдел помогает осуществить:

- Регистрацию проекта у производителя компонентов.
- Техническую поддержку проекта.
- Защиту от снятия компонента с производства.
- Оценку стоимости проекта по компонентам.
- Изготовление тестовой платы монтаж и пусконаладочные работы.



Тел: +7 (812) 336 43 04 (многоканальный)

Email: org@lifeelectronics.ru