

# NCP4303A, NCP4303B

## Secondary Side Synchronous Rectification Driver for High Efficiency SMPS Topologies

The NCP4303A/B is a full featured controller and driver tailored to control synchronous rectification circuitry in switch mode power supplies. Thanks to its versatility, it can be used in various topologies such as flyback, forward and Half Bridge Resonant LLC.

The combination of externally adjustable minimum on and off times helps to fight the ringing induced by the PCB layout and other parasitic elements. Therefore, a reliable and noise less operation of the SR system is insured.

The extremely low turn off delay time, high sink current capability of the driver and automatic package parasitic inductance compensation system allow to maximize synchronous rectification MOSFET conduction time that enables further increase of SMPS efficiency.

Finally, a wide operating  $V_{CC}$  range combined with two versions of driver voltage clamp eases implementation of the SR system in 24 V output applications.

### Features

- Self-Contained Control of Synchronous Rectifier in CCM, DCM, and QR Flyback Applications
- Precise True Secondary Zero Current Detection with Adjustable Threshold
- Automatic Parasitic Inductance Compensation Input
- Typically 40 ns Turn off Delay from Current Sense Input to Driver
- Zero Current Detection Pin Capability up to 200 V
- Optional Ultrafast Trigger Interface for Further Improved Performance in Applications that Work in Deep CCM
- Disable Input to Enter Standby or Low Consumption Mode
- Adjustable Minimum On Time Independent of  $V_{CC}$  Level
- Adjustable Minimum Off Time Independent of  $V_{CC}$  Level
- 5 A / 2.5 A Peak Current Sink / Source Drive Capability
- Operating Voltage Range up to 30 V
- Gate Drive Clamp of Either 12 V (NCP4303A) or 6 V (NCP4303B)
- Low Startup and Standby Current Consumption
- Maximum Frequency of Operation up to 500 kHz
- SOIC-8 Package
- These are Pb-Free Devices

### Typical Applications

- Notebook Adapters
- High Power Density AC/DC Power Supplies
- Gaming Consoles
- All SMPS with High Efficiency Requirements



ON Semiconductor®

<http://onsemi.com>

### MARKING DIAGRAM

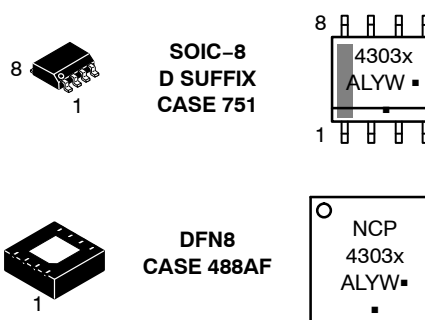

4303x = Specific Device Code  
 x = A or B  
 A = Assembly Location  
 L = Wafer Lot  
 Y = Year  
 W = Work Week  
 ■ = Pb-Free Package

(\*Note: Microdot may be in either location)

### PINOUT INFORMATION

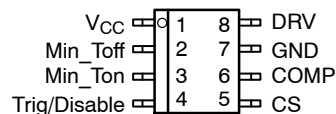

(NOTE: For DFN the exposed pad must be either unconnected or preferably connected to ground. The GND pin must be always connected to ground.)

### ORDERING INFORMATION

Device	Package	Shipping†
NCP4303ADR2G	SOIC-8 (Pb-Free)	2500 / Tape & Reel
NCP4303BDR2G	SOIC-8 (Pb-Free)	2500 / Tape & Reel
NCP4303AMNTWG	DFN8 (Pb-Free)	4000 / Tape & Reel
NCP4303BMNTWG	DFN8 (Pb-Free)	4000 / Tape & Reel

†For information on tape and reel specifications, including part orientation and tape sizes, please refer to our Tape and Reel Packaging Specifications Brochure, BRD8011/D.

# NCP4303A, NCP4303B

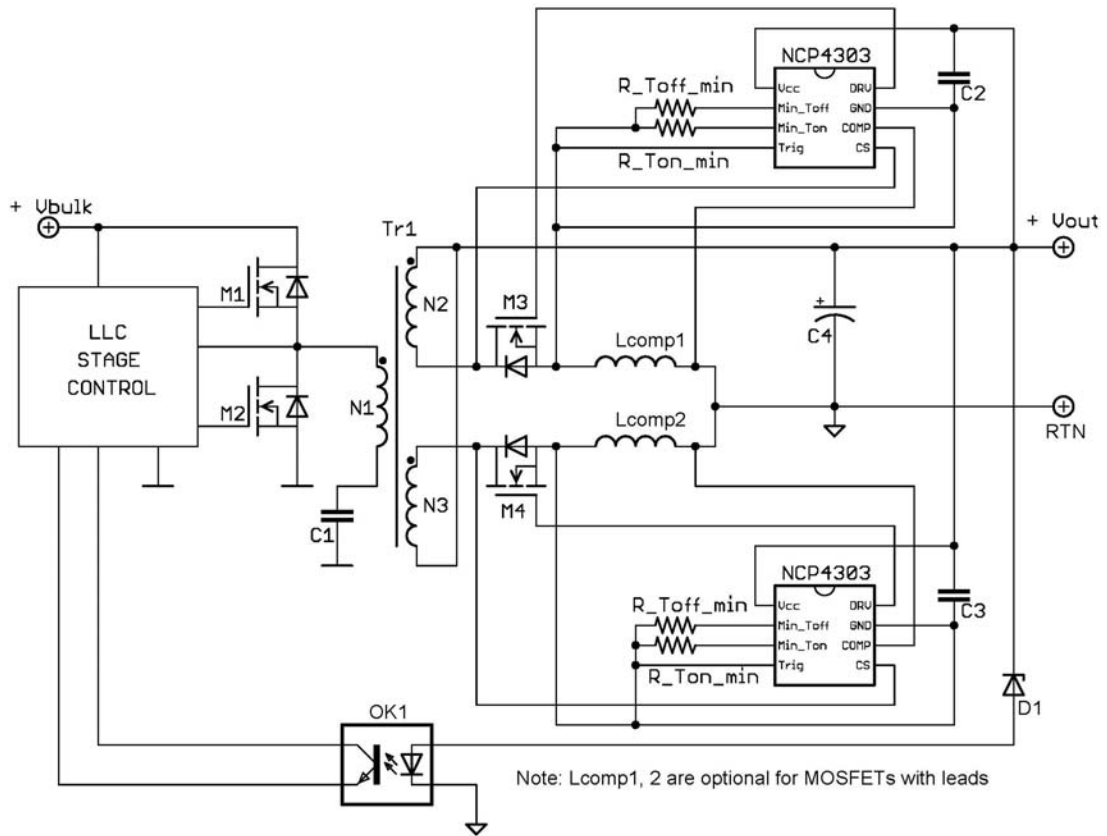

Figure 1. Typical Application Example – LLC Converter

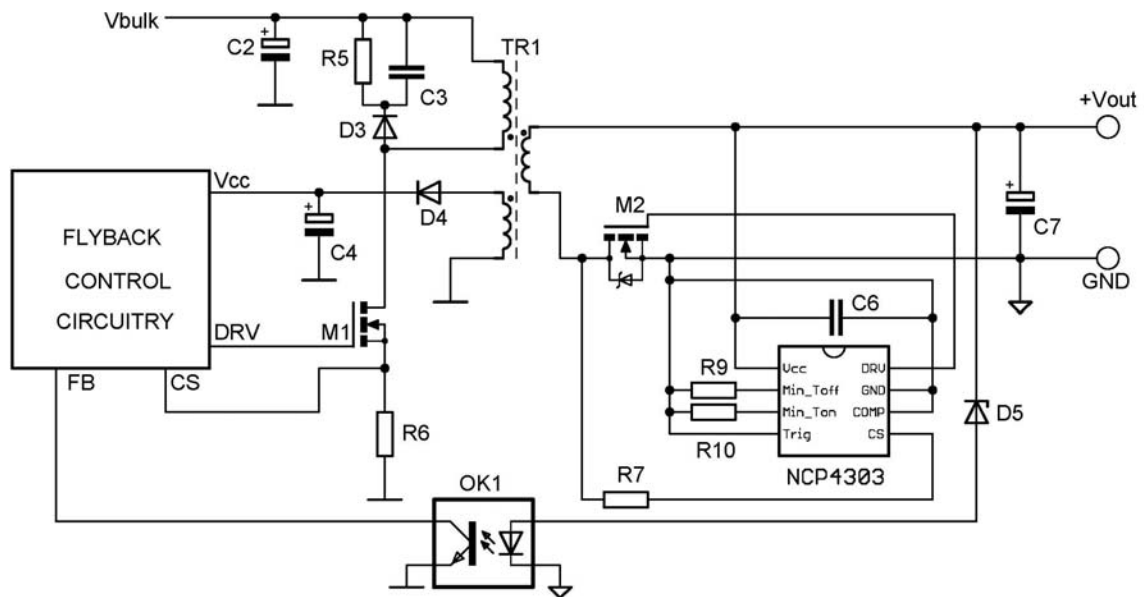

Figure 2. Typical Application Example – DCM, QR or CCM Flyback Converter

# NCP4303A, NCP4303B

## PIN FUNCTION DESCRIPTION

Pin No.	Pin Name	Function	Pin Description
1	VCC	Supplies the driver	V <sub>CC</sub> supply terminal of the controller. Accepts up to 30 V continuously.
2	Min_toff	Minimum off time adjust	Adjust the minimum off time period by connecting resistor to ground.
3	Min_ton	Minimum on time adjust	Adjust the minimum on time period by connecting resistor to ground.
4	TRIG/Disable	Forced reset input	This ultrafast turn-off input offers the possibility to further improve efficiency and performance in applications that work in deep Continuous Conduction Mode (CCM). Activates sleep mode if pulled up for more than 100 μs. Connect this pin to GND when not used.
5	CS	Current sense of the SR MOSFET	This pin detects if the current flows through the SR MOSFET and/or its body diode. Basic turn off detection threshold is 0 mV. A resistor in series with this pin can modify the turn off threshold if needed.
6	COMP	Compensation inductance connection	Use as a Kelvin connection to auxiliary compensation inductance. If SR MOSFET package parasitic inductance compensation is not used (like for SMT MOSFETs), connect this pin directly to GND pin.
7	GND	IC ground	Ground connection for the SR MOSFET driver and V <sub>CC</sub> decoupling capacitor. Ground connection for minimum ton, toff adjust resistors and trigger input. GND pin should be wired directly to the SR MOSFET source terminal/soldering point using Kelvin connection.
8	DRV	Gate driver output	Driver output for the SR MOSFET.

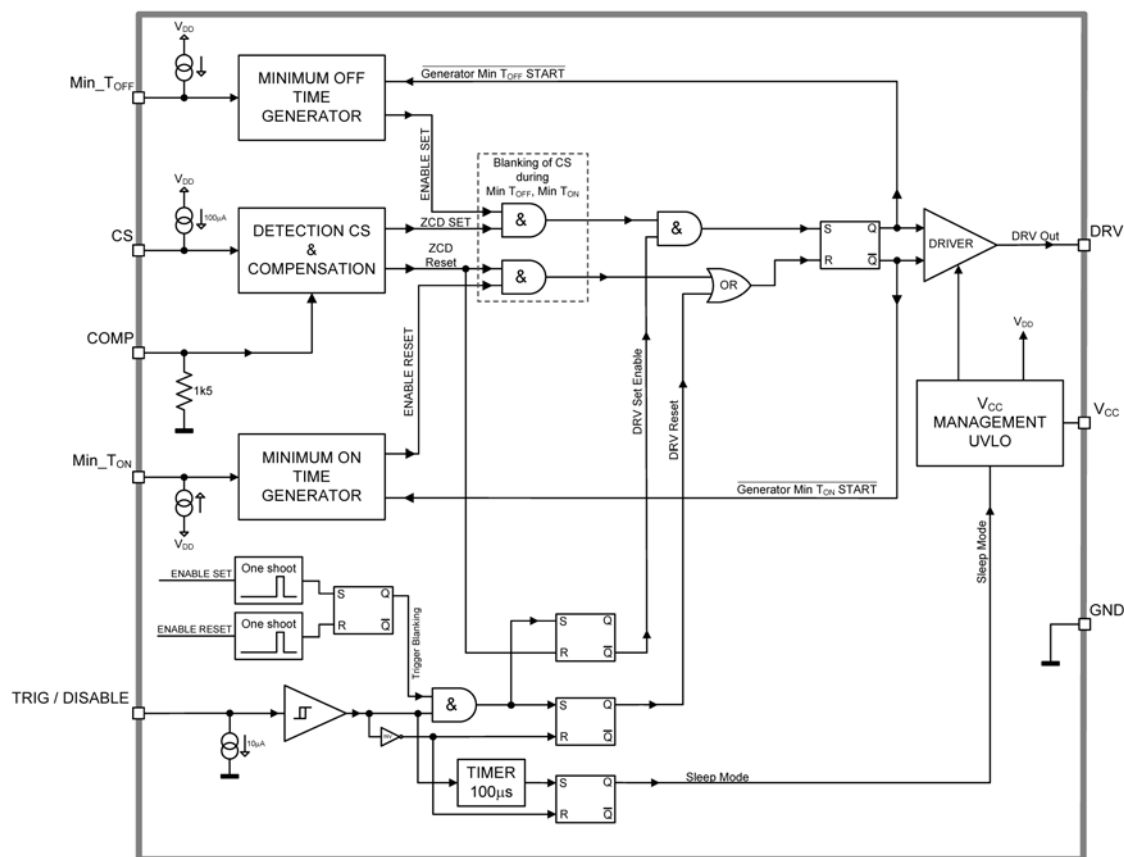

Figure 3. Internal Circuit Architecture

# NCP4303A, NCP4303B

## MAXIMUM RATINGS

Symbol	Rating	Value	Unit
$V_{CC}$	IC supply voltage	-0.3 to 30	V
$V_{DRV}$	Driver output voltage	-0.3 to 17	V
$V_{CS}$	Current sense input dc voltage	-4 to 200	V
$V_{Csdyn}$	Current sense input dynamic voltage ( $t_{pw} = 200$ ns)	-10 to 200	V
$V_{TRIG}$	Trigger input voltage	-0.3 to 10	V
$V_{Min\_ton}, V_{Min\_toff}$	Min_Ton and Min_Toff input voltage	-0.3 to 10	V
$I_{Min\_Toff}, I_{Min\_Toff}$	Min_Ton and Min_Toff current	-10 to +10	mA
VGND-COMP	Static voltage difference between GND and COMP pins (internally clamped)	-3 to 10	V
VGND-COMP_dyn	Dynamic voltage difference between GND and COMP pins ( $t_{pw} = 200$ ns)	-10 to 10	V
ICOMP	Current into COMP pin	-5 to 5	mA
$R_{\theta JA}$	Thermal Resistance Junction-to-Air, SOIC version, A/B version	180	°C/W
$R_{\theta JA}$	Thermal Resistance Junction-to-Air, DFN - A/B versions, 50 mm <sup>2</sup> - 1.0 oz. Copper spreader	180	°C/W
$R_{\theta JA}$	Thermal Resistance Junction-to-Air, DFN - A/B versions, 600 mm <sup>2</sup> - 1.0 oz. Copper spreader	80	°C/W
$T_{Jmax}$	Maximum junction temperature	150	°C
$T_{Smax}$	Storage Temperature Range	-60 to +150	°C
$T_{Lmax}$	Lead temperature (Soldering, 10 s)	300	°C
	ESD Capability, Human Body Model except pin $V_{CS}$ - pin 5, HBM ESD Capability on pin 5 is 650 V	2	kV
	ESD Capability, Machine Model	200	V

Stresses exceeding Maximum Ratings may damage the device. Maximum Ratings are stress ratings only. Functional operation above the Recommended Operating Conditions is not implied. Extended exposure to stresses above the Recommended Operating Conditions may affect device reliability.

- This device series contains ESD protection and exceeds the following tests:  
 Pin 1 - 8: Human Body Model 2000 V per JEDEC Standard JESD22-A114E.  
 Machine Model Method 200 V pre JEDEC Standard JESD22-A115-A
- This device meets latchup tests defined by JEDEC Standard JESD78.

# NCP4303A, NCP4303B

**ELECTRICAL CHARACTERISTICS** (For typical values  $T_J = 25^\circ\text{C}$ , for min/max values  $T_J = -40^\circ\text{C}$  to  $+125^\circ\text{C}$ , Max  $T_J = 150^\circ\text{C}$ ,  $V_{CC} = 12\text{ V}$ ,  $C_{load} = 0\text{ nF}$ ,  $R_{min\_ton} = R_{min\_toff} = 10\text{ k}\Omega$ ,  $V_{trig} = 0\text{ V}$ ,  $f_{CS} = 100\text{ kHz}$ ,  $DC_{CS} = 50\%$ ,  $V_{CS\_high} = 4\text{ V}$ ,  $V_{CS\_low} = -1\text{ V}$  unless otherwise noted)

Symbol	Rating	Pin	Min	Typ	Max	Unit
--------	--------	-----	-----	-----	-----	------

## SUPPLY SECTION

$V_{CC\_on}$	Turn-on threshold level ( $V_{CC}$ going up)	1	9.3	9.9	10.5	V
$V_{CC\_off}$	Minimum operating voltage after turn-on ( $V_{CC}$ going down)	1	8.3	8.9	9.5	V
$V_{CC\_hyste}$	$V_{CC}$ hysteresis	1	0.8	1.0	1.3	V
$I_{CC1\_A}$ $I_{CC1\_B}$	Internal IC consumption (no output load on pin 8, $F_{sw} = 500\text{ kHz}$ , $R_{Ton\_min} = R_{Toff\_min} = 5\text{ k}\Omega$ )	1	-	4.7 4	-	mA
$I_{CC2\_A}$ $I_{CC2\_B}$	Internal IC consumption ( $C_{load} = 1\text{ nF}$ on pin 8, $F_{sw} = 400\text{ kHz}$ , $R_{Ton\_min} = R_{Toff\_min} = 5\text{ k}\Omega$ )	1	-	9.3 6.4	-	mA
$I_{CC3\_A}$ $I_{CC3\_B}$	Internal IC consumption ( $C_{load} = 10\text{ nF}$ on pin 8, $F_{sw} = 400\text{ kHz}$ , $R_{Ton\_min} = R_{Toff\_min} = 5\text{ k}\Omega$ )	1	-	54 34	-	mA
$I_{CC\_SDM}$	Startup current consumption ( $V_{CC} = V_{CC\_on} - 0.1\text{ V}$ ) and consumption during light load (disable) mode, ( $F_{sw} = 500\text{ kHz}$ , $V_{trig} = 5\text{ V}$ )	1	-	390	550	$\mu\text{A}$
$I_{CC\_SDM\ NS}$	Startup current consumption ( $V_{CC} = V_{CC\_on} - 0.1\text{ V}$ ) and consumption during light load (disable) mode, ( $V_{cs} = 0\text{ V}$ , $V_{trig} = 5\text{ V}$ )	1	-	280	450	$\mu\text{A}$

## DRIVE OUTPUT

$t_{r\_A}$	Output voltage rise-time for A version ( $C_{load} = 10\text{ nF}$ ), (Note 3)	8	-	120	-	ns
$t_{r\_B}$	Output voltage rise-time for B version ( $C_{load} = 10\text{ nF}$ ), (Note 3)	8	-	80	-	ns
$t_{f\_A}$	Output voltage fall-time for A version ( $C_{load} = 10\text{ nF}$ ), (Note 3)	8	-	50	-	ns
$t_{f\_B}$	Output voltage fall-time for B version ( $C_{load} = 10\text{ nF}$ ), (Note 3)	8	-	35	-	ns
$R_{oh}$	Driver source resistance (Note 3)	8	-	1.8	7	$\Omega$
$R_{ol}$	Driver sink resistance	8	-	1	2	$\Omega$
$I_{DRV\_pk(source)}$	Output source peak current (Note 3)	8	-	2.5	-	A
$I_{DRV\_pk(sink)}$	Output sink peak current (Note 3)	8	-	5	-	A
$V_{DRV(H)\_A}$	Driver high level output voltage on A version ( $C_{load} = 1\text{ nF}$ )	8	10	-	-	V
$V_{DRV(H)\_A}$	Driver high level output voltage on A version ( $C_{load} = 10\text{ nF}$ )	8	11.8	-	-	V
$V_{DRV(H)\_B}$	Driver high level output voltage on B version ( $C_{load} = 1\text{ nF}$ )	8	5	-	-	V
$V_{DRV(H)\_B}$	Driver high level output voltage on B version ( $C_{load} = 10\text{ nF}$ )	8	6	-	-	V
$V_{DRV(min)\_A}$	Minimum drive output voltage for A version ( $V_{CC} = V_{CC\_off} + 200\text{ mV}$ )	8	8.3	-	-	V
$V_{DRV(min)\_B}$	Minimum drive output voltage for B version ( $V_{CC} = V_{CC\_off} + 200\text{ mV}$ )	8	4.5	-	-	V
$V_{DRV(CLMP)\_A}$	Driver clamp voltage for A version, ( $12\text{ V} < V_{CC} < 28\text{ V}$ , minimum $C_{load} = 1\text{ nF}$ )	8	-	12	16	V
$V_{DRV(CLMP)\_B}$	Driver clamp voltage for B version, ( $12\text{ V} < V_{CC} < 28\text{ V}$ , minimum $C_{load} = 1\text{ nF}$ )	8	-	7	8.3	V

## CS INPUT

$T_{pd\_on}$	The total propagation delay from CS input to DRV output turn on ( $V_{CS}$ goes down from $4\text{ V}$ to $-1\text{ V}$ , $t_{f\_CS} = 5\text{ ns}$ , COMP pin connected to GND)	5, 8	-	60	90	ns
$T_{pd\_off}$	The total propagation delay from CS input to DRV output turn off ( $V_{CS}$ goes up from $-1\text{ V}$ to $4\text{ V}$ , $t_{r\_CS} = 5\text{ ns}$ , COMP pin connected to GND), (Note 3)	5, 8	-	40	55	ns
$I_{shift\_CS}$	Current sense input current source ( $V_{CS} = 0\text{ V}$ )	5	95	100	105	$\mu\text{A}$
$V_{th\_cs\_on}$	Turn on current sense input threshold voltage	5, 8	-120	-85	-50	mV
$V_{th\_cs\_off}$	Current sense pin turn off threshold voltage, COMP pin connected to GND (Note 3)	5, 8	-1	-	0	mV
$G_{comp}$	Compensation inverter gain (Note 3)	5, 6, 8	-	-1	-	-

3. Guaranteed by design.

## NCP4303A, NCP4303B

**ELECTRICAL CHARACTERISTICS** (For typical values  $T_J = 25^\circ\text{C}$ , for min/max values  $T_J = -40^\circ\text{C}$  to  $+125^\circ\text{C}$ , Max  $T_J = 150^\circ\text{C}$ ,  $V_{CC} = 12\text{ V}$ ,  $C_{load} = 0\text{ nF}$ ,  $R_{min\_ton} = R_{min\_toff} = 10\text{ k}\Omega$ ,  $V_{trig} = 0\text{ V}$ ,  $f_{CS} = 100\text{ kHz}$ ,  $DC_{CS} = 50\%$ ,  $V_{CS\_high} = 4\text{ V}$ ,  $V_{CS\_low} = -1\text{ V}$  unless otherwise noted)

Symbol	Rating	Pin	Min	Typ	Max	Unit
--------	--------	-----	-----	-----	-----	------

### CS INPUT

$I_{CS\_Leakage}$	CS input leakage current, $V_{CS} = 200\text{ Vdc}$	5	-	-	1	$\mu\text{A}$
-------------------	---	---	---	---	---	---------------

### TRIGGER/DISABLE INPUT

$T_{trig\_pw}$	Minimum trigger pulse duration	4	30	-	-	ns
$V_{trig}$	Trigger input threshold voltage ( $V_{trig}$ goes up)	4	1.5	-	2.5	V
$t_{p\_trig}$	Propagation delay from trigger input to the DRV output ( $V_{trig}$ goes up from 0 to 5 V $t_{r\_trig} = 5\text{ ns}$ )	4	-	-	30	ns
$t_{trig\_light\_load}$	Light load turn off filter duration	4	-	100	-	$\mu\text{s}$
$t_{trig\_light\_load\_rec}$	IC operation recovery time when leaving light load disable mode ( $V_{trig}$ goes down from 5 to 0 V $t_{f\_trig} = 5\text{ ns}$ )	4	-	-	550	ns
$I_{trig}$	Trigger input pull down current ( $V_{trig} = 5\text{ V}$ )	4	-	10	-	$\mu\text{A}$

### MINIMUM $T_{on}$ AND $T_{off}$ ADJUST

$T_{on\_min}$	Minimum $T_{on}$ period ( $R_{T\_on\_min} = 0\ \Omega$ )	3	-	300	-	ns
$T_{off\_min}$	Minimum $T_{off}$ period ( $R_{T\_off\_min} = 0\ \Omega$ )	2	-	620	-	ns
$T_{on\_min}$	Minimum $T_{on}$ period ( $R_{T\_on\_min} = 10\text{ k}\Omega$ )	3	0.9	1.0	1.1	$\mu\text{s}$
$T_{off\_min}$	Minimum $T_{off}$ period ( $R_{T\_off\_min} = 10\text{ k}\Omega$ )	2	0.9	1.0	1.1	$\mu\text{s}$
$T_{on\_min}$	Minimum $T_{on}$ period ( $R_{T\_on\_min} = 50\text{ k}\Omega$ )	3	-	4.8	-	$\mu\text{s}$
$T_{off\_min}$	Minimum $T_{off}$ period ( $R_{T\_off\_min} = 50\text{ k}\Omega$ )	2	-	4.8	-	$\mu\text{s}$

3. Guaranteed by design.

# NCP4303A, NCP4303B

## TYPICAL CHARACTERISTICS

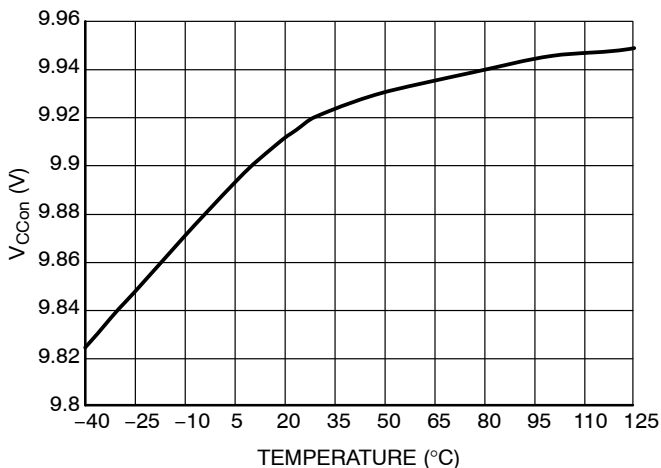

Figure 4. V<sub>CC</sub> Startup Voltage

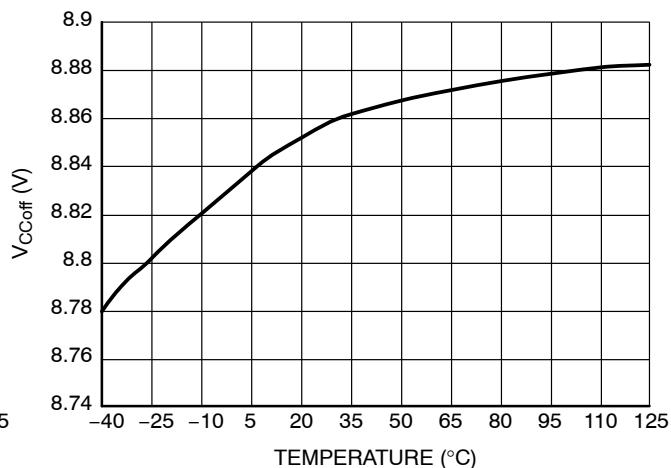

Figure 5. V<sub>CC</sub> Turn-off Voltage

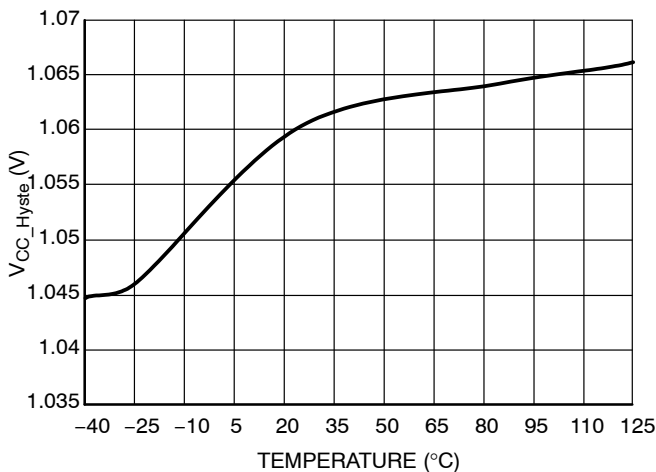

Figure 6. V<sub>CC</sub> Hysteresis

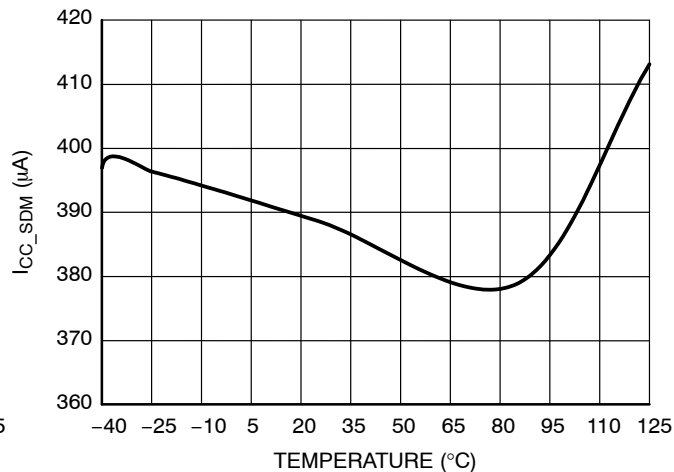

Figure 7. Startup Current

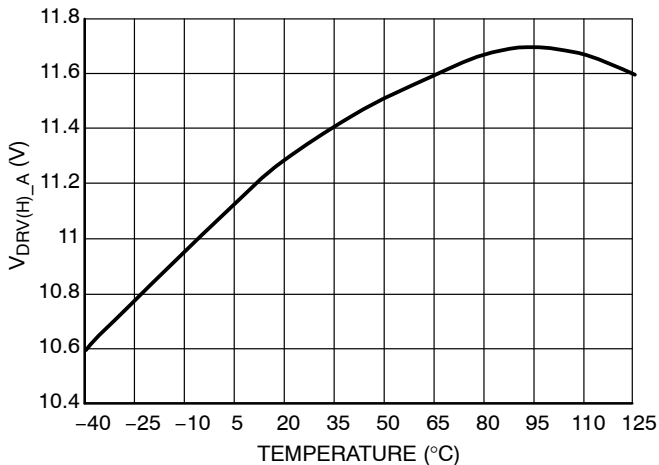

Figure 8. Driver High Level – A Version,  
V<sub>CC</sub> = 12 V and C<sub>load</sub> = 1 nF

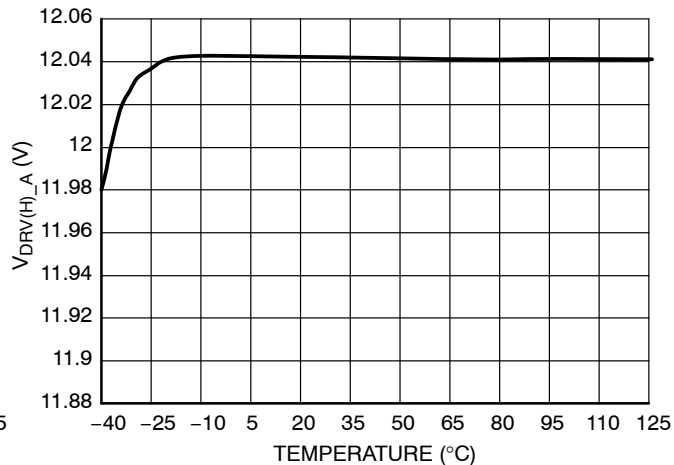

Figure 9. Driver High Level– A Version, V<sub>CC</sub> =  
12 V and C<sub>load</sub> = 10 nF

# NCP4303A, NCP4303B

## TYPICAL CHARACTERISTICS

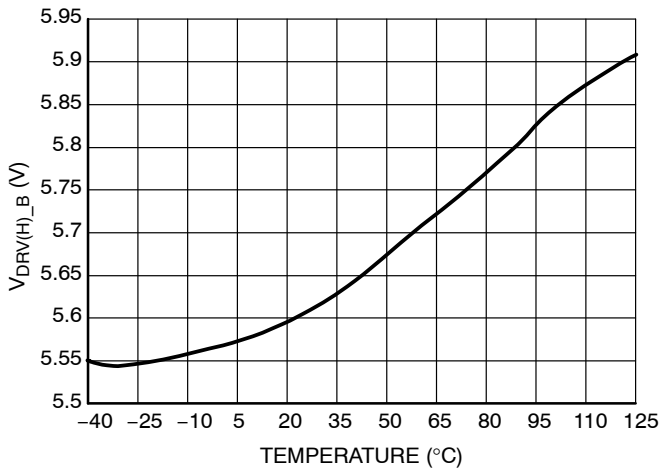

Figure 10. Driver High Level – B Version,  $V_{CC} = 12\text{ V}$  and  $C_{load} = 1\text{ nF}$

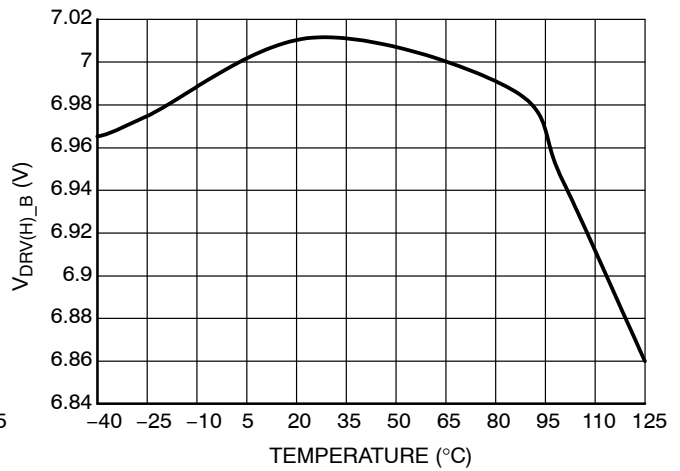

Figure 11. Driver High Level – B Version,  $V_{CC} = 12\text{ V}$  and  $C_{load} = 10\text{ nF}$

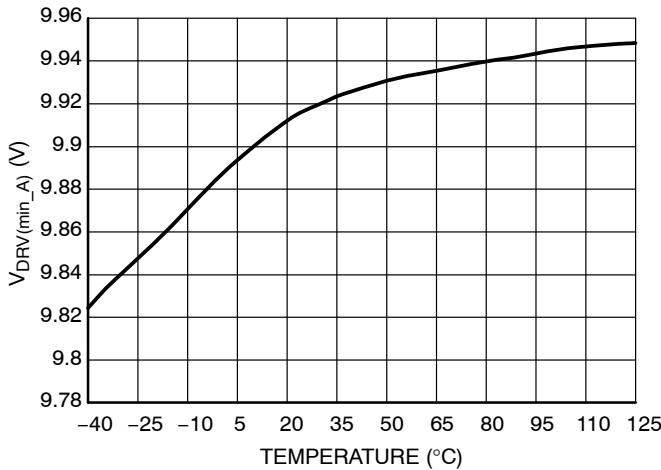

Figure 12. Minimal Driver High Level – A Version,  $V_{CC} = V_{CC\_OFF} + 0.2\text{ V}$  and  $C_{load} = 0\text{ nF}$

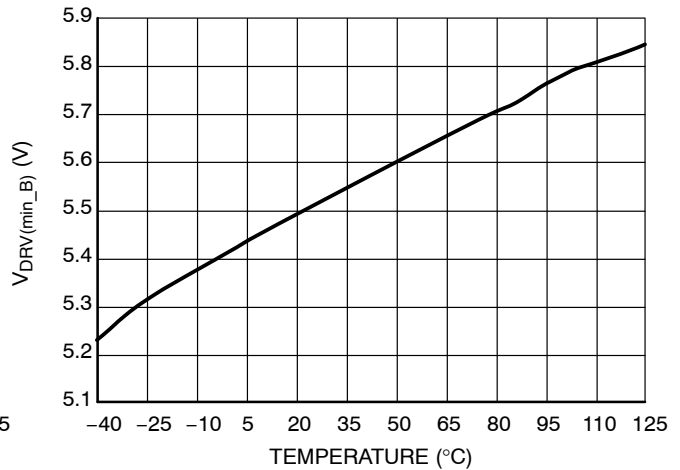

Figure 13. Minimal Driver High Level – B Version,  $V_{CC} = V_{CC\_OFF} + 0.2\text{ V}$  and  $C_{load} = 0\text{ nF}$

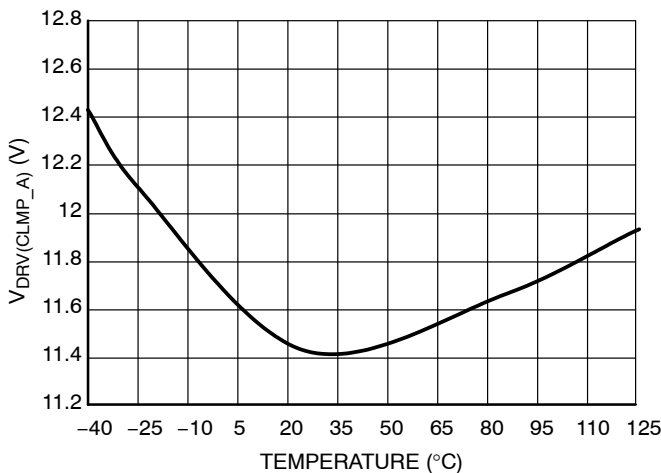

Figure 14. Driver Clamp Level – A Version,  $V_{CC} = 28\text{ V}$  and  $C_{load} = 1\text{ nF}$

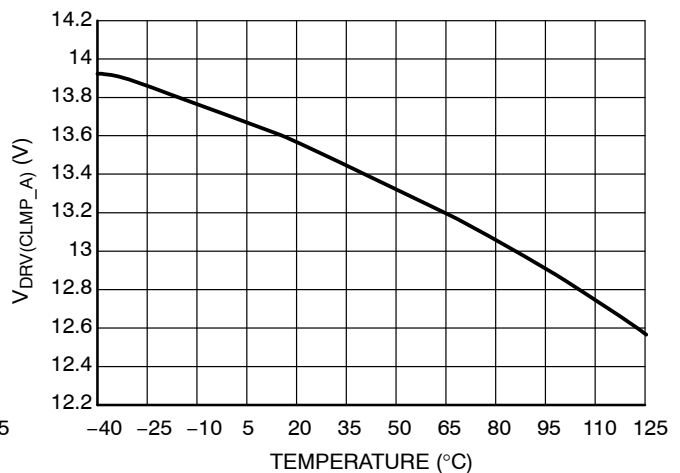
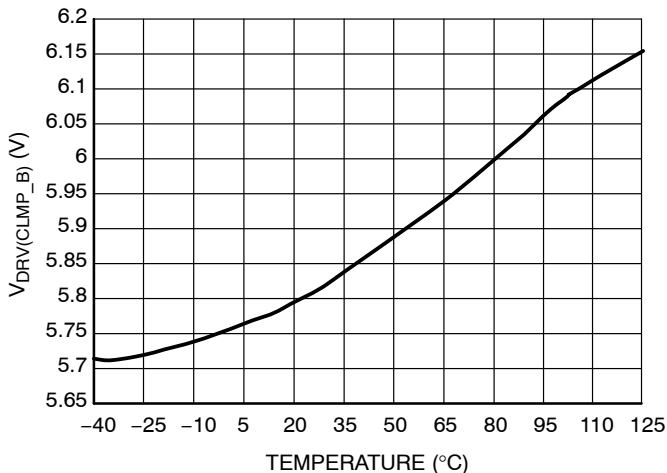

Figure 15. Driver Clamp Level – A Version,  $V_{CC} = 28\text{ V}$  and  $C_{load} = 10\text{ nF}$

# NCP4303A, NCP4303B

## TYPICAL CHARACTERISTICS



**Figure 16. Driver Clamp Level – B Version,  
V<sub>CC</sub> = 28 V and C<sub>load</sub> = 1 nF**

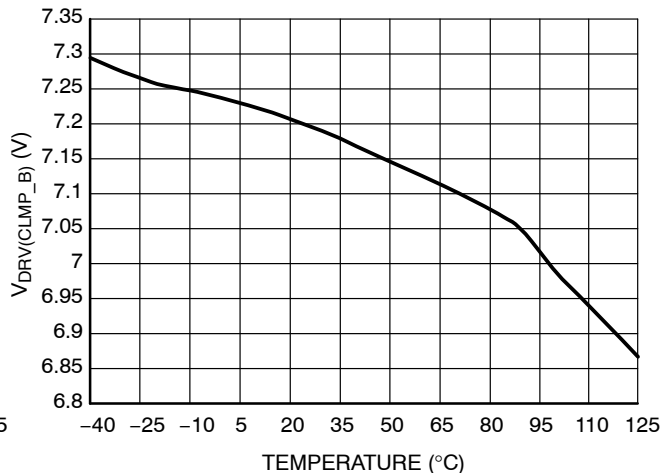

**Figure 17. Driver Clamp Level – B Version,  
V<sub>CC</sub> = 28 V and C<sub>load</sub> = 10 nF**

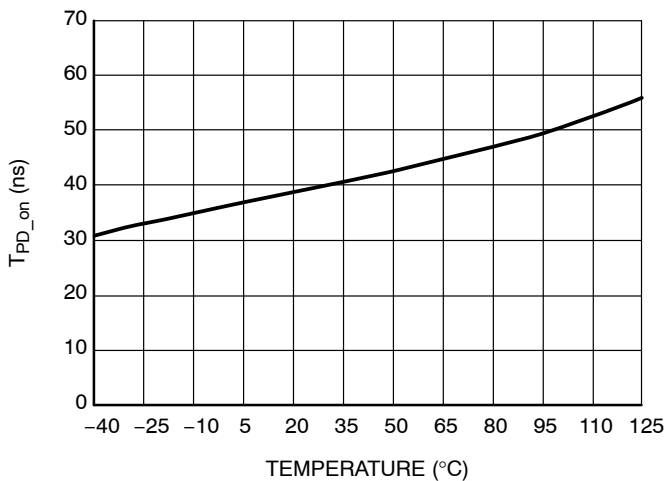

**Figure 18. CS to DRV Turn-on Propagation  
Delay**

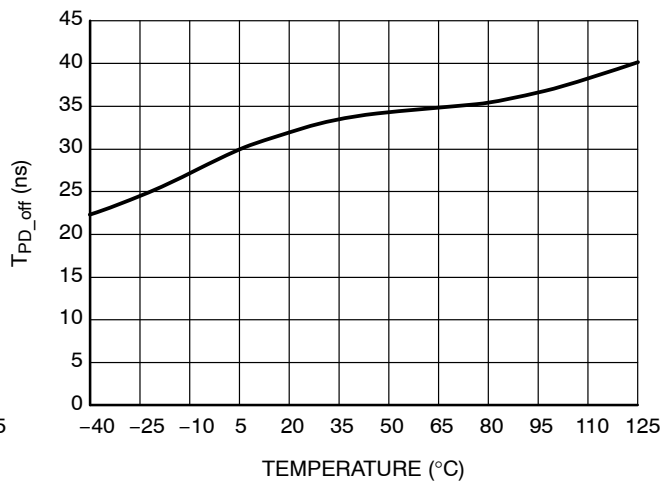

**Figure 19. CS to DRV Turn-off Propagation  
Delay**

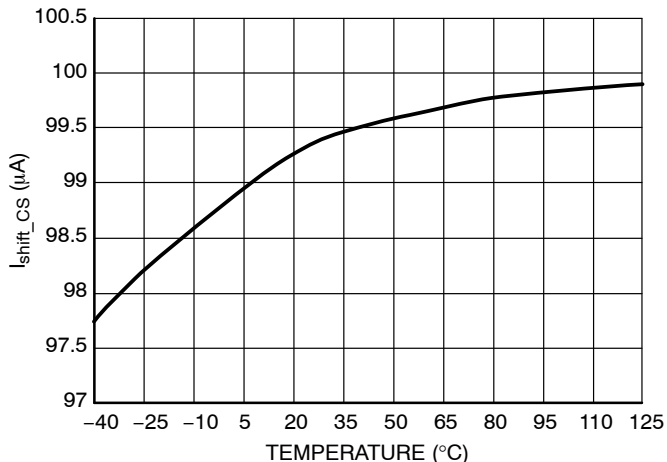

**Figure 20. CS Pin Shift Current**

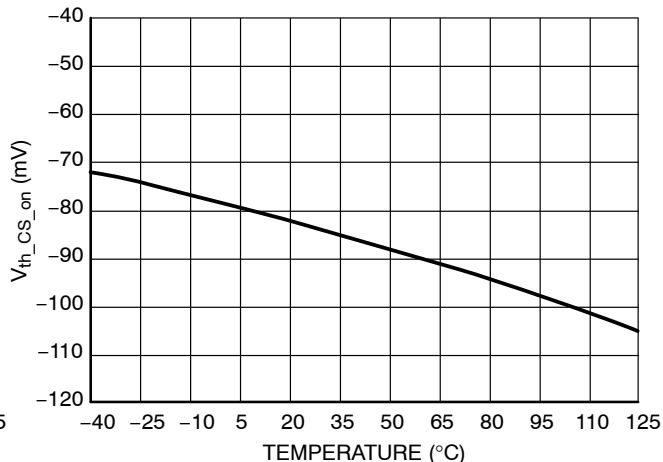

**Figure 21. CS Turn-on Threshold**

TYPICAL CHARACTERISTICS

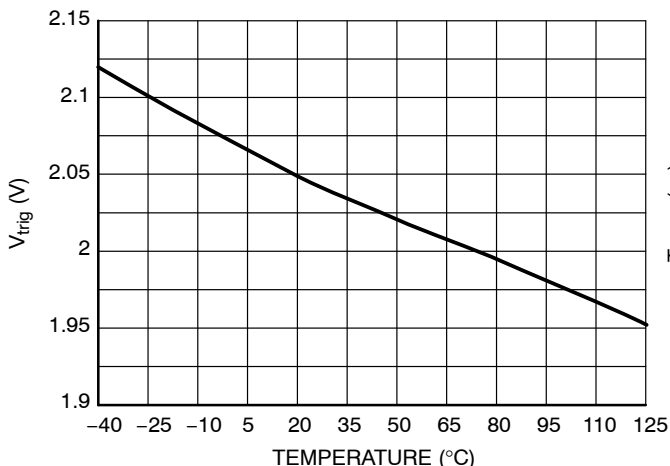

Figure 22. Trigger Input Threshold Voltage

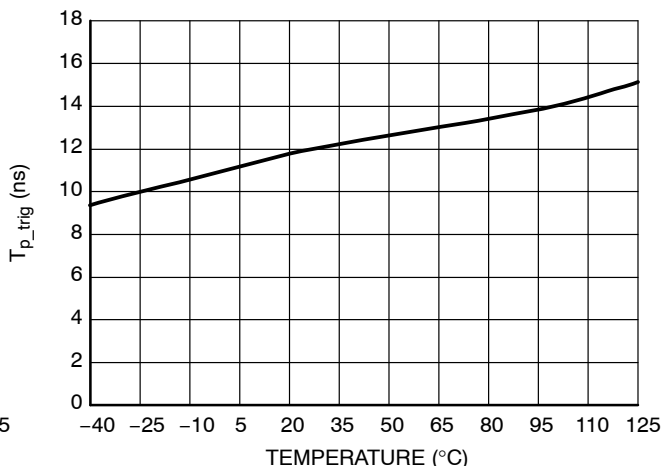

Figure 23. Propagation Delay from Trigger Input to DRV Turn-off

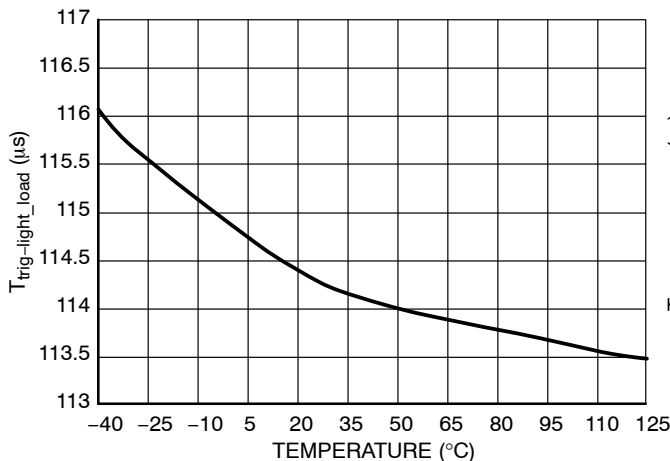

Figure 24. Light Load Transition Timer Duration

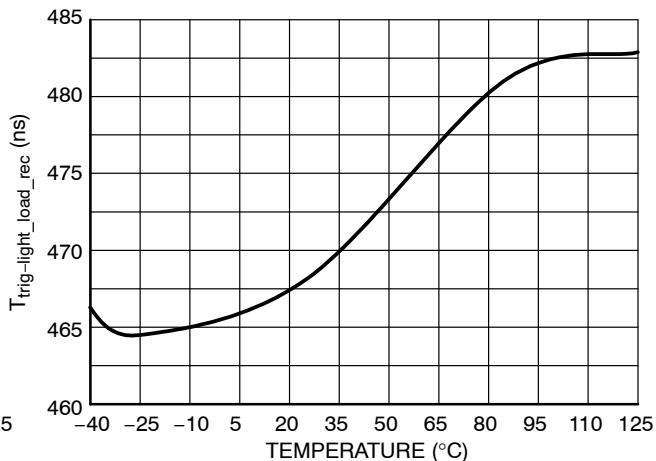

Figure 25. Light Load to Normal Operation Recovery Time

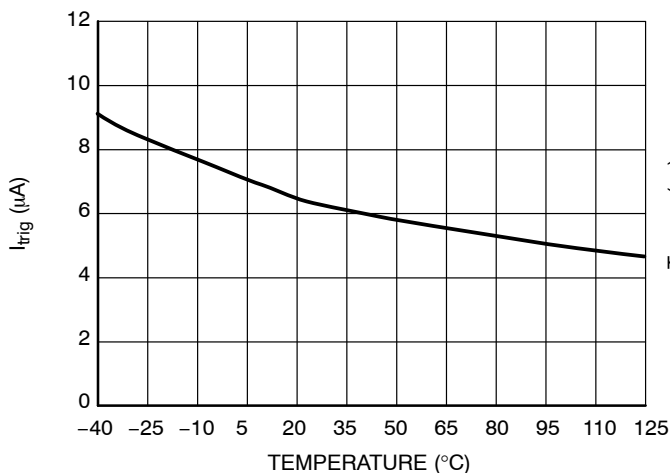

Figure 26. Trigger Input Pulldown Current

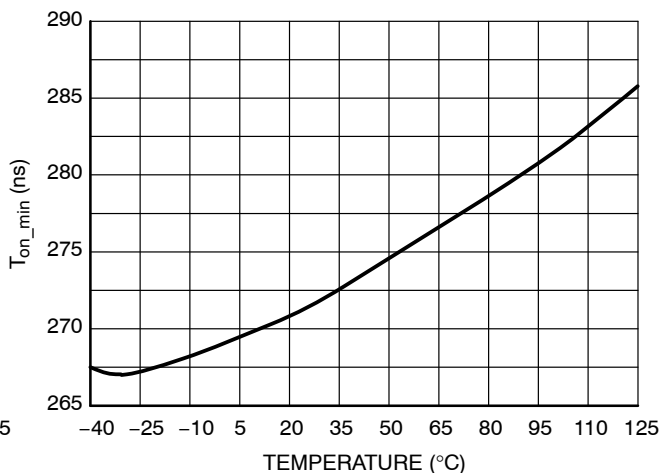
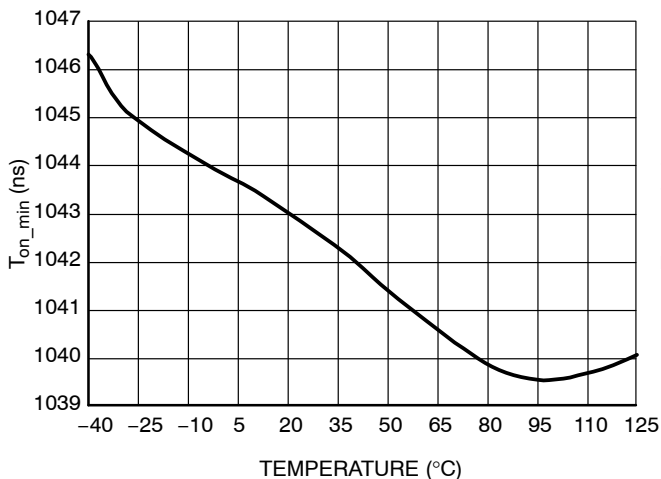

Figure 27. Minimum on Time @ R<sub>t\_on\_min</sub> = 0 Ω

# NCP4303A, NCP4303B

## TYPICAL CHARACTERISTICS



**Figure 28. Minimum on Time @  $R_{t\_on\_min} = 10\text{ k}\Omega$**

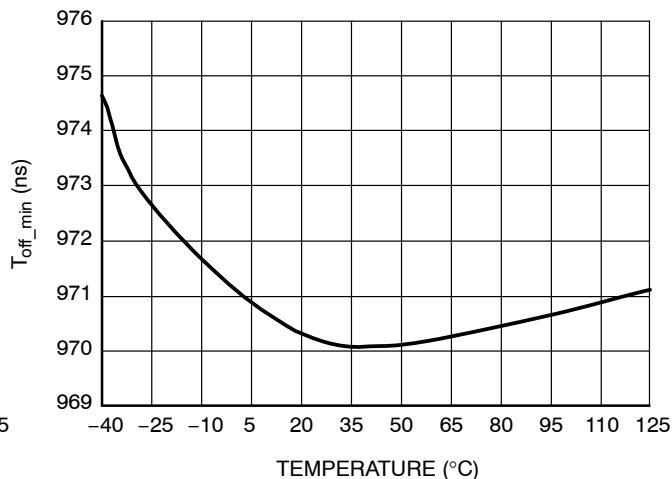

**Figure 29. Minimum Off Time @  $R_{t\_off\_min} = 10\text{ k}\Omega$**

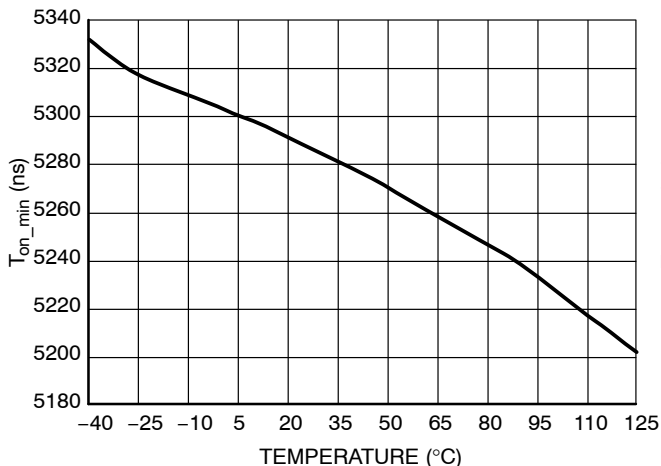

**Figure 30. Minimum on Time @  $R_{t\_on\_min} = 53\text{ k}\Omega$**

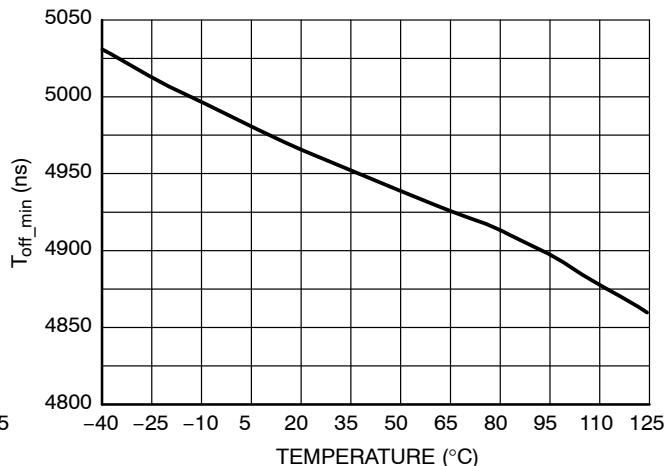

**Figure 31. Minimum Off Time @  $R_{t\_off\_min} = 53\text{ k}\Omega$**

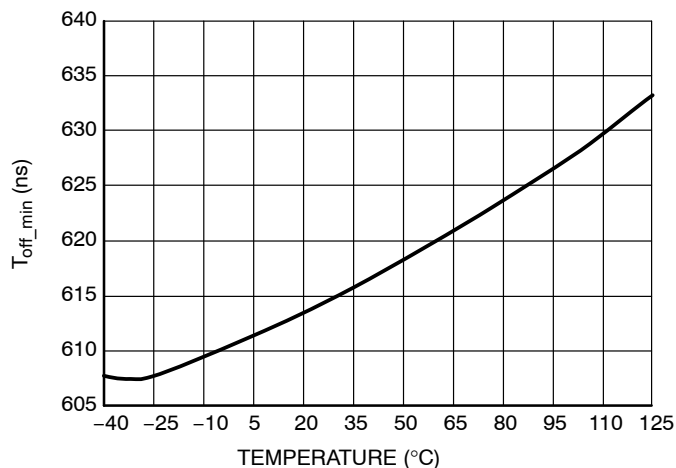

**Figure 32. Minimum Off Time @  $R_{t\_off\_min} = 0\ \Omega$**

## APPLICATION INFORMATION

### General Description

The NCP4303 is designed to operate either as a standalone IC or as a companion IC to a primary side controller to help achieve efficient synchronous rectification in switch mode power supplies. This controller features a high current gate driver along with high-speed logic circuitry to provide appropriately timed drive signals to a synchronous rectification MOSFET. With its novel architecture, the NCP4303 has enough versatility to keep the synchronous rectification system efficient under any operating mode.

The NCP4303 works from an available bias supply with voltage range from 10.4 V to 28 V (typical). The wide  $V_{CC}$  range allows direct connection to the SMPS output voltage of most adapters such as notebook and LCD TV adapters. As a result, the NCP4303 simplifies circuit operation compared to other devices that require specific bias power supply (e.g. 5 V). The high voltage capability of the  $V_{CC}$  pin is also a unique feature designed to allow operation for a broader range of applications.

Precise turn off threshold of the current sense comparator together with accurate offset current source allows the user to adjust for any required turn off current threshold of the SR MOSFET switch using a single resistor. Compared to other SR controllers that provide turn off thresholds in the range of -10 mV to -5 mV, the NCP4303 offers a turn off threshold of 0 mV that in combination with a low  $R_{DS(on)}$  SR MOSFET significantly reduces the turn off current threshold and improves efficiency.

To overcome issues after turn on and off events, the NCP4303 provides adjustable minimum on time and off time blanking periods. Blanking times can be adjusted independently of IC  $V_{CC}$  using resistors connected to GND. If needed, blanking periods can be modulated using additional components.

The NCP4303 ZCD comparator features very short turn-off delay time. This allows the SR controller to be used in applications operating in shallow CCM mode without any extra primary side synchronization circuitry (refer to Figures 2 and 60). This circuit exhibits excellent efficiency

results (refer to Figures 58 and 59). A typical example of such an application is a flyback notebook adapter that usually enters only shallow CCM when  $V_{bulk}$  is lower than approximately 180 Vdc. On the other hand, the turn-off delay could be too long for applications operating in deep CCM (like high output current flyback or forward converters). High reverse current spikes and also drain voltage ringing are then usually present on the SR MOSFET. This is because the SR MOSFET needs some time to fully turn-off. The NCP4303 offers an optional ultrafast turn-off trigger input to prevent these current spikes and drain voltage ringing. This input can be used to turn-off the SR MOSFET earlier, using a synchronization signal from the primary side. The SR MOSFET is then turned-off prior to its drain voltage reversing thus the reverse current is minimized while the efficiency is maximized (refer to Figure 46 for a deep CCM flyback converter example). Using the trigger input is optional and only recommended for applications operating in deep CCM. Additionally, the trigger input can be used to disable the IC and activate a low consumption standby mode. This feature can be used to decrease standby consumption of an SMPS.

Finally, the NCP4303 features a special input that can be used to automatically compensate for SR MOSFET parasitic inductance effect. This technique achieves the maximum available on-time and thus optimizes efficiency when a MOSFET in standard package (like TO220 or TO247) is used. If a SR MOSFET in SMT package with negligible inductance is used, the compensation input is connected to GND pin.

### Zero Current Detection and parasitic inductance compensation

Figure 33 shows the internal connection of the ZCD circuitry on the current sense input. The synchronous rectification MOSFET is depicted with its parasitic inductances to demonstrate operation of the compensation system.

## NCP4303A, NCP4303B

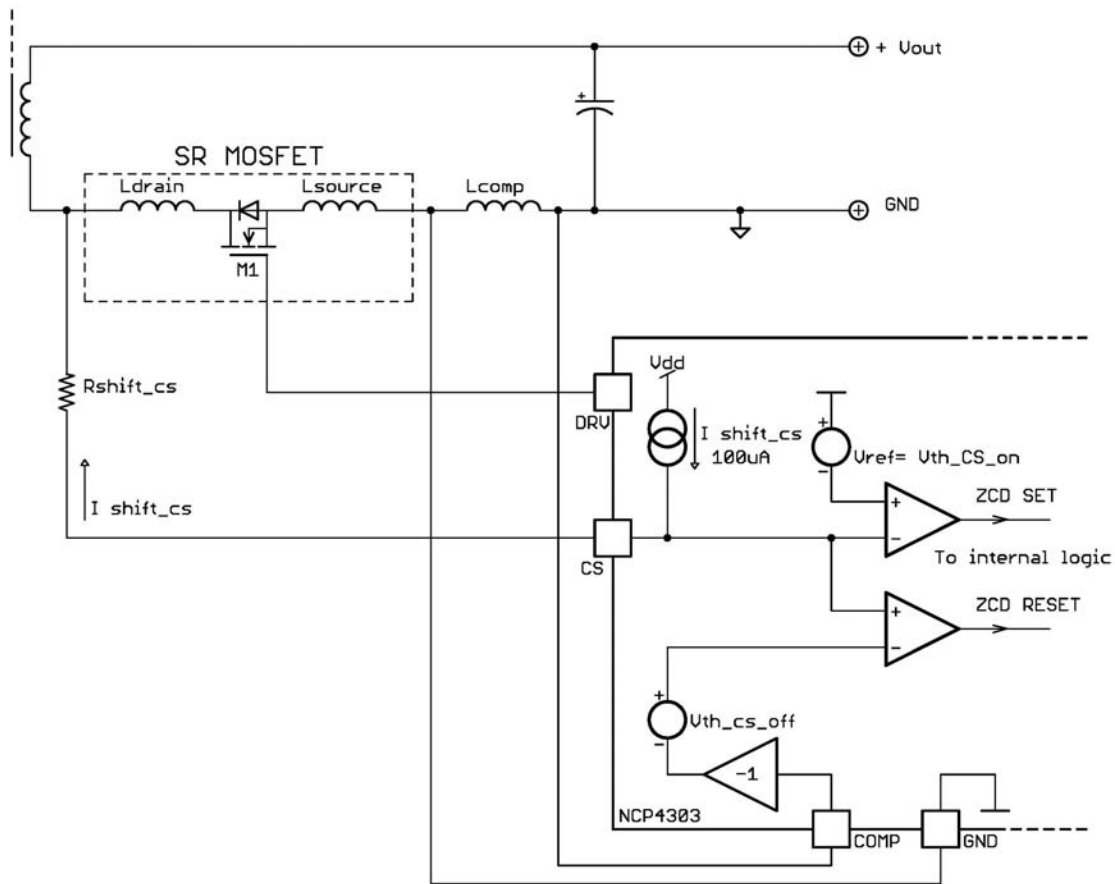

**Figure 33. ZCD Sensing Circuitry Functionality**

When the voltage on the secondary winding of the SMPS reverses, the body diode of M1 starts to conduct current and the voltage of M1's drain drops approximately to  $-1$  V. The CS pin sources current of  $100 \mu\text{A}$  that creates a voltage drop on the  $R_{\text{shift\_cs}}$  resistor. Once the voltage on the CS pin is lower than  $V_{\text{th\_cs\_on}}$  threshold, M1 is turned on. Because of parasitic impedances, significant ringing can occur in the application. To overcome sudden turn-off due to mentioned ringing, the minimum conduction time of the SR MOSFET is activated. Minimum conduction time can be adjusted using  $R_{\text{Min\_Ton}}$  resistor.

The SR MOSFET is turned-off as soon as the voltage on the CS pin is higher than  $V_{\text{th\_cs\_off}}$ . For the same ringing reason, a minimum off time timer is asserted once the turn-off is detected. The minimum off time can be externally adjusted using  $R_{\text{Min\_Toff}}$  resistor. MOSFET M1 channel conducts when the secondary current decreases, therefore the turn-off time depends on its  $R_{\text{DS(on)}}$ . The  $0$  mV threshold provides an optimum switching period usage while keeping enough time margin for the gate turn off. The  $R_{\text{shift\_cs}}$  resistor provides the designer with the possibility to modify (increase) the actual turn-off current threshold.

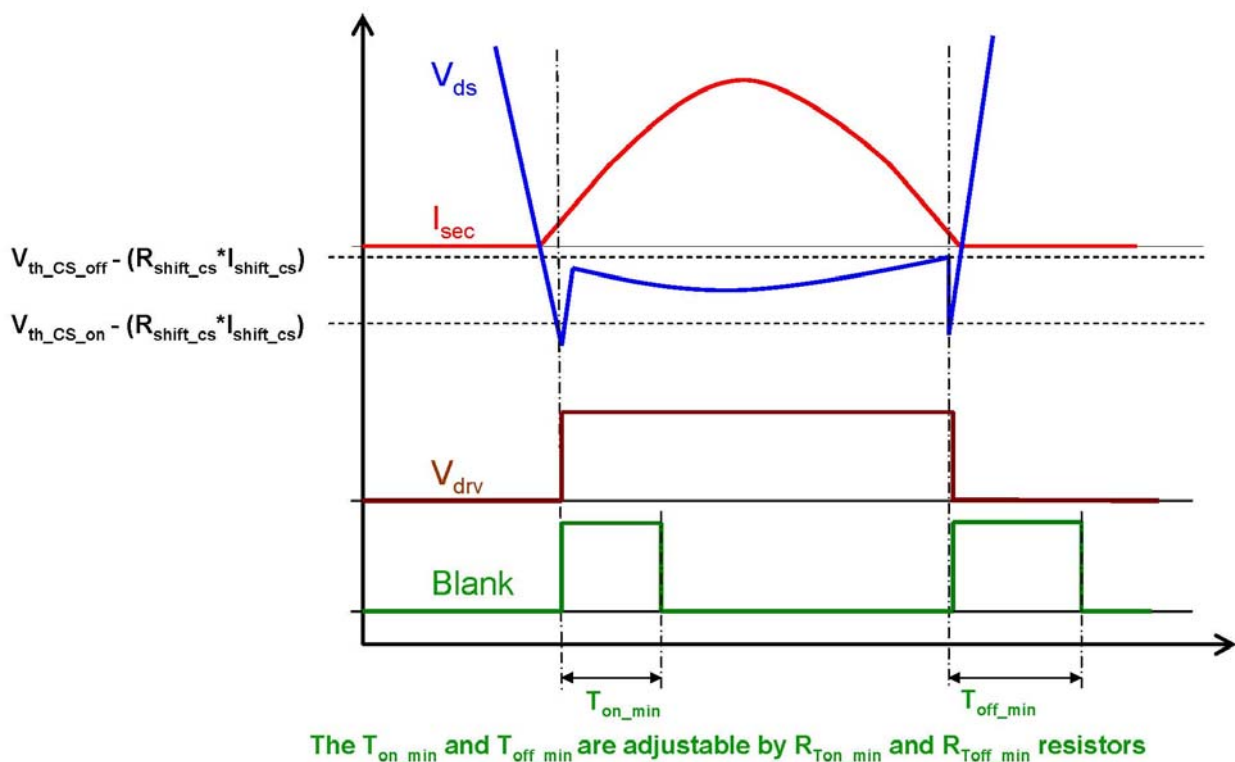

Figure 34. ZCD Comparators Thresholds and Blanking Periods Timing

If no  $R_{shift\_cs}$  resistor is used, the turn-on and turn-off thresholds are fully given by the CS input specification (please refer to parametric table). Once non-zero  $R_{shift\_cs}$  resistor is used, both thresholds move down (i.e. higher MOSFET turn off current) as the CS pin offset current causes a voltage drop that is equal to:

$$V_{R_{shift\_cs}} = R_{shift\_cs} * I_{shift\_cs} \quad (\text{eq. 1})$$

Final turn-on and turn off thresholds can be then calculated as:

$$V_{CS\_turn\_on} = V_{th\_CS\_on} - (R_{shift\_cs} * I_{shift\_cs}) \quad (\text{eq. 2})$$

$$V_{CS\_turn\_off} = V_{th\_CS\_off} - (R_{shift\_cs} * I_{shift\_cs}) \quad (\text{eq. 3})$$

Note that  $R_{shift\_cs}$  impact on turn-on threshold is less critical compare to turn-off threshold.

If using a SR MOSFET in TO220 package (or other package which features leads), the parasitic inductance of the package leads causes a turn-off current threshold increase. This is because current that flows through the SR MOSFET has quite high  $di(t)/dt$  that induces error voltage on the SR MOSFET leads inductance. This error voltage, that is proportional to the secondary current derivative, shifts the CS input voltage to zero when significant current still flows through the channel. Zero current threshold is thus detected when current still flows through the SR MOSFET channel – please refer to Figure 35 for better understanding. As a result, the SR MOSFET is turned-off prematurely and the efficiency of the SMPS is not optimized.

## NCP4303A, NCP4303B

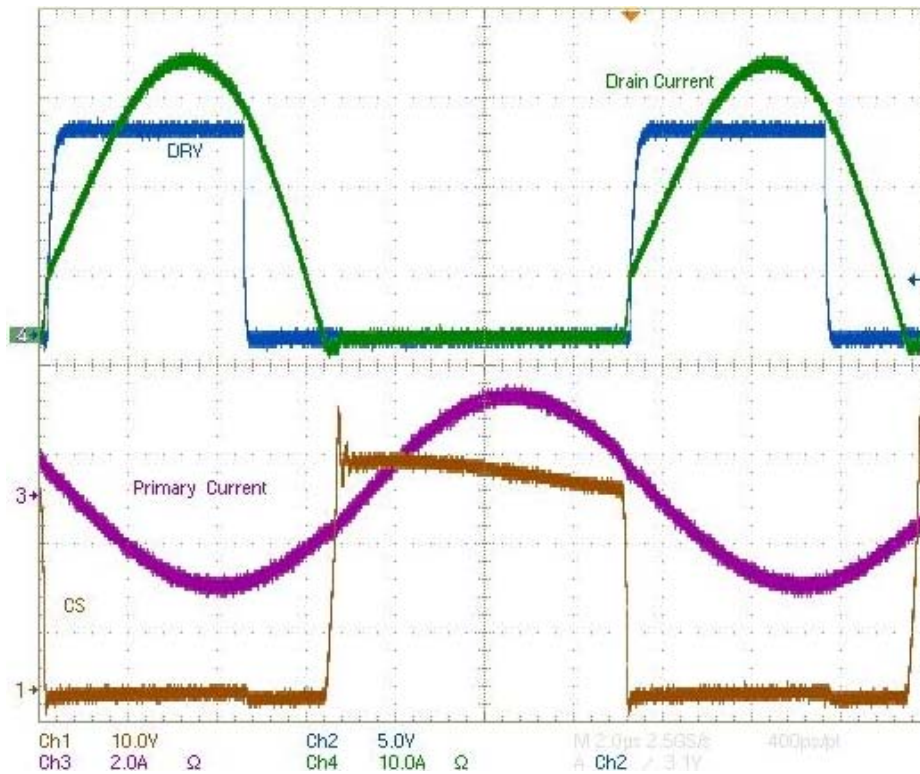

**Figure 35. Waveforms from SR System Using MOSFET in TO220 Package without Parasitic Inductance Compensation – SR MOSFET Channel Conduction Time is Reduced**

Note that the efficiency impact of the error caused by parasitic inductance increases with lower  $R_{DS(on)}$  MOSFETs and/or higher operating frequency.

The NCP4303 offers a way to compensate for MOSFET parasitic inductances effect – refer to Figure 36.

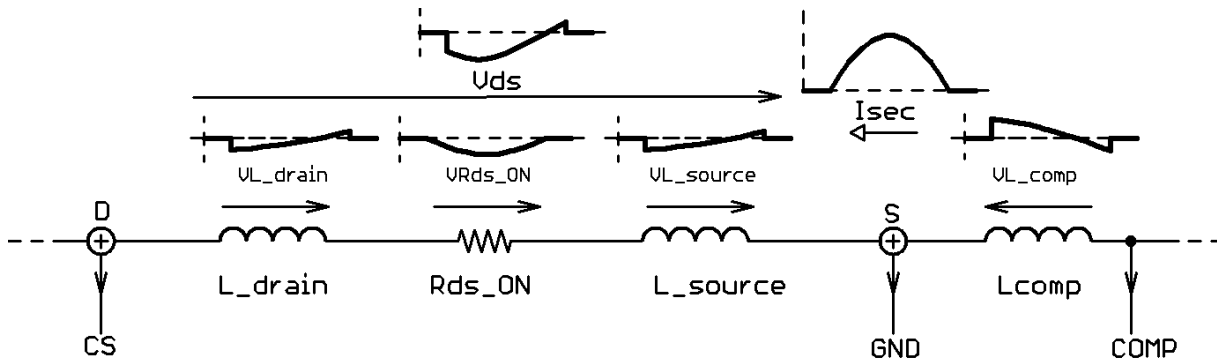

**Figure 36. Package Parasitic Inductances Compensation Principle**

Dedicated input (COMP) offers the possibility to use an external compensation inductance (wire strap or PCB). If the value of this compensation inductance is  $L_{comp} = L_{drain} + L_{source}$ , the compensation voltage created on this inductance is exactly the same as the sum of error voltages created on drain and source parasitic inductances i.e.  $V_{L_{drain}} + V_{L_{source}}$ . The internal analog inverter (Figure 33) inverts compensation voltage  $V_{I_{comp}}$  and offsets the current sense comparator turn-off threshold. The current sense comparator thus “sees” between its terminals a voltage that

would be seen on the SR MOSFET channel resistance in case the lead inductances wouldn’t exist. The current sense comparator of the NCP4303 is thus able to detect the secondary current zero crossing very precisely. More over, the secondary current turn-off threshold is then  $di(t)/t$  independent thus the NCP4303 allows to increase operating frequency of the SR system. One should note that the parasitic resistance of compensation inductance should be as low as possible compared to the SR MOSFET channel and leads resistance otherwise compensation is not efficient.

## NCP4303A, NCP4303B

Typical value of compensation inductance for a TO220 package is 7 nH. The parasitic inductance can differ depends on how much are the leads shortened during the assembly process. The compensation inductance design has to be done with enough margin to overcome situation that the system

will become overcompensated due to packaging and assembly process variations. Waveforms from the application with compensated SR system can be seen in Figure 37. One can see the conduction time has been significantly increased and turn-off current reduced.

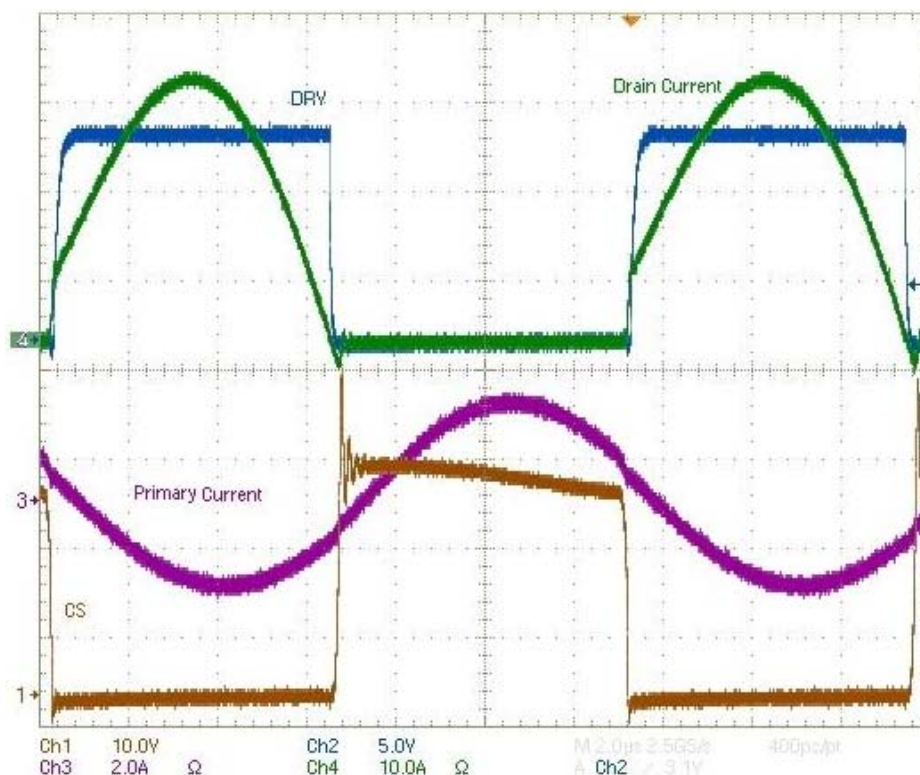

**Figure 37. Waveforms from SR System Using MOSFET in TO220 Package with Parasitic Inductance Compensation – SR MOSFET Channel Conduction Time Optimized**

Note that using the compensation system is only beneficial in applications that are using a low  $R_{DS(on)}$  MOSFET in non-SMT package. Using the compensation method allows for optimized efficiency with a standard TO220 package that in turn results in reduced costs, as the SMT MOSFETs usually require reflow soldering process and more expensive PCB.

From the above paragraphs and parameter tables it is evident that turn-off threshold precision is quite critical. If we consider a SR MOSFET with  $R_{DS(on)}$  of 1 m $\Omega$ , the 1 mV error voltage on the CS pin results in a 1 A turn-off current threshold difference. Thus the PCB layout is very critical when implementing the SR system. Note that the CS turn-off comparator as well as compensation inputs are referred to the GND pin. Any parasitic impedance (resistive or inductive – talking about m $\Omega$  and nH values) can cause a high error voltage that is then evaluated by the CS

comparator. Ideally the CS turn-off comparator should detect voltage that is caused by secondary current directly on the SR MOSFET channel resistance. Practically this is not possible because of the bonding wires, leads and soldering. To assure the best efficiency results, a Kelvin connection of the SR controller to the power circuitry should be implemented (i.e. GND pin should be connected to the SR MOSFET source soldering point and current sense pin should be connected to the SR MOSFET drain soldering point). Any impact of PCB parasitic elements on the SR controller functionality is then avoided. Figures 38 and 39 show examples of SR system layouts using parasitic inductance compensation (i.e. for low  $R_{DS(on)}$  MOSFET in TO220 package) and not using compensation (i.e. for higher  $R_{DS(on)}$  MOSFET in TO220 package or SMT package MOSFETs).

## NCP4303A, NCP4303B

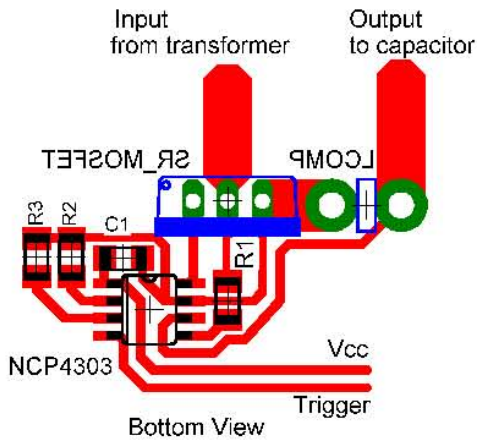

**Figure 38. Recommended Layout for SO8 Package When Parasitic Inductance Compensation is Used**

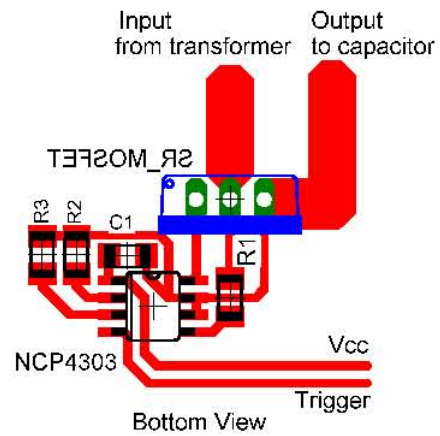

**Figure 39. Recommended Layout for SO8 Package When Parasitic Inductance Compensation is Not Used**

### Trigger/Disable input

The NCP4303 features an ultrafast trigger input that exhibits a typically of 12 ns delay from its activation to the turn-off of the SR MOSFET. This input offers a possibility to turn-off the SR MOSFET in applications that operates in deep CCM via a signal coming from the primary side. Efficiency and SR performance can be thus further optimized (refer also to application information on page 12). The primary trigger signal rising edge should come to the trigger input before the secondary voltage reverses. Thus the driver signal for primary switch should be delayed – refer to figure 46 for one possible method of delaying the primary

driving signal in CCM flyback topology. The trigger signal is disabled from the end of the minimum off time period to the end of the minimum on time period. This technique is used to:

- a) Overcome false turn-off of the gate driver in case the synchronization pulse is too wide and comes twice per switching period (in HB and HB LLC applications).
- b) Increase trigger input noise immunity against the parasitic ringing that is present in the SMPS layout during the turn on process.

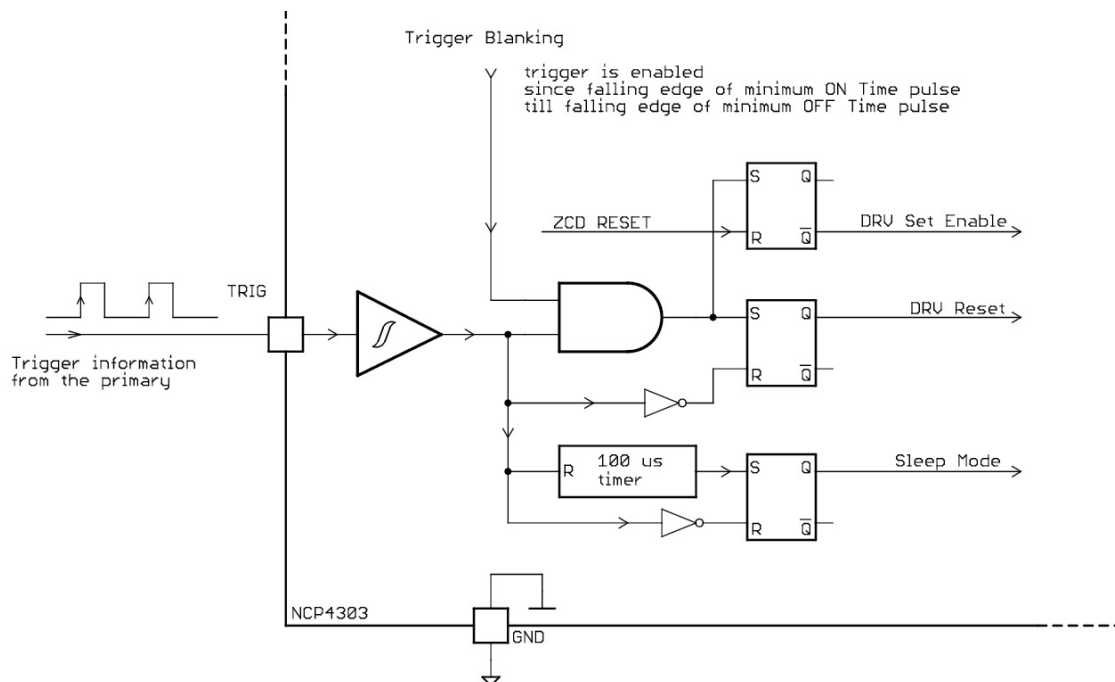

**Figure 40. Trigger Input Internal Connection**

## NCP4303A, NCP4303B

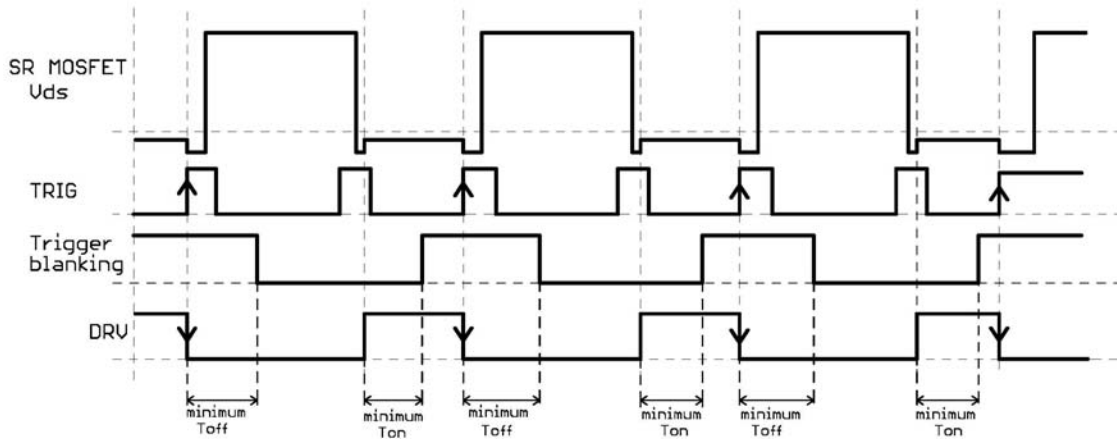

**Figure 41. Trigger Input Functionality Waveforms**

The NCP4303 operation can be disabled using the trigger/disable input. If the trigger/disable input is pulled up (above 1.5 V) the driver is disabled immediately. In some cases, the driver is activated one more time by the current sense because the trigger signal is still blanked. This final drive pulse lasts only for the minimum on time period. If the trigger signal is high for more than 100  $\mu\text{s}$ , the driver enters standby mode. Note that a short pulse (2  $\mu\text{s}$  maximally) can appear on the DRV pin during transition to sleep mode in case there was no switching on the CS input prior transition – refer to Figure 44. This behavior is related to the internal

IC logic structure and may cause unwanted SR MOSFET activation in some applications. It is recommended to disable NCP4303 driver via  $V_{CC}$  pin in such cases – refer to Figure 61. The IC consumption is reduced to 390  $\mu\text{A}$  during the standby mode. When trigger input voltage is decreased again the device recovers operation in 500 ns. If the IC is enabled in the time the current sense input voltage is negative (secondary current flows through the Schottky or body diode) the IC waits for another switching cycle to turn-on the SR MOSFET – refer to Figures 42, 43 44, and 45.

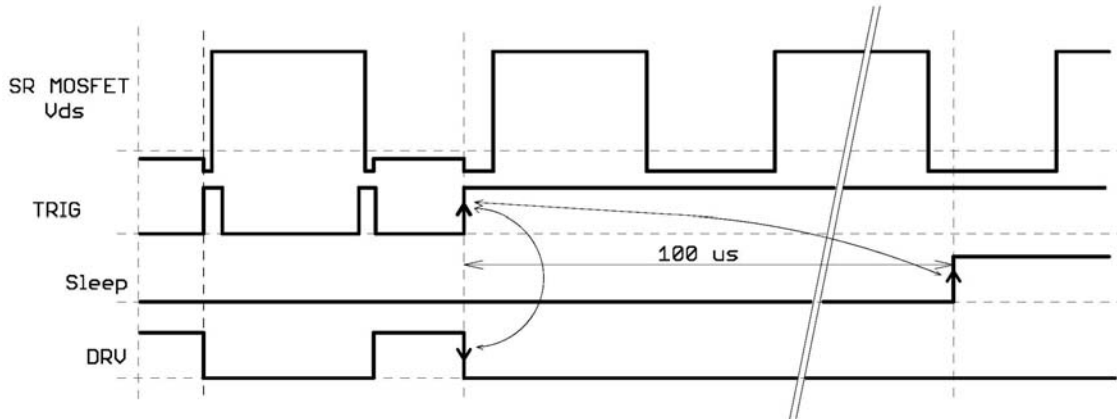

**Figure 42. Operating Waveforms for the Trig/Disable Input – Device Sleep Mode Transition – Case 1**

# NCP4303A, NCP4303B

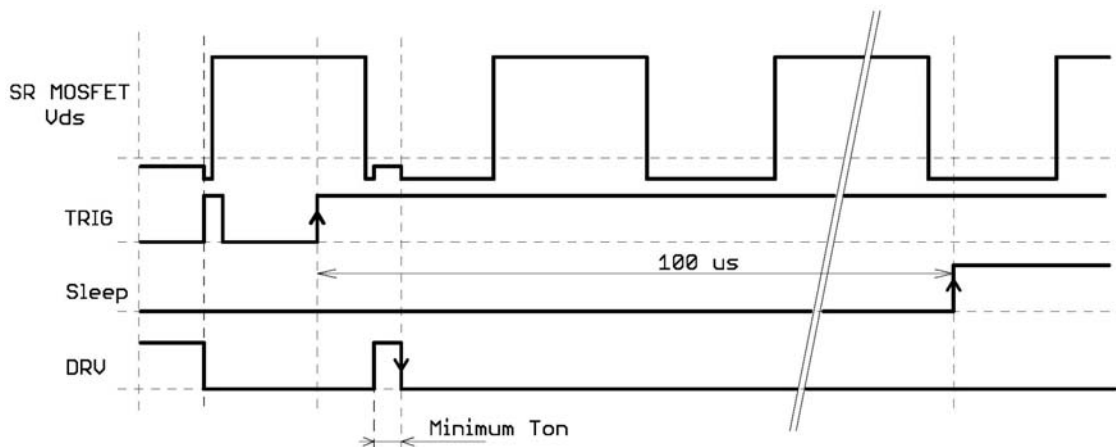

Figure 43. Operating Waveforms for the Trig/Disable Input – Device Sleep Mode Transition – Case 2

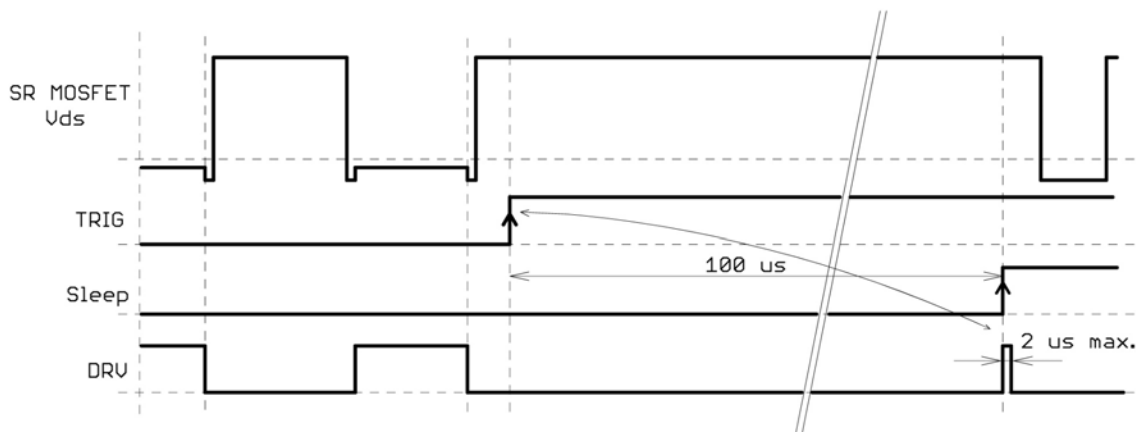

Figure 44. Operating Waveforms for the Trig/Disable Input – Device Sleep Mode Transition – Case 3

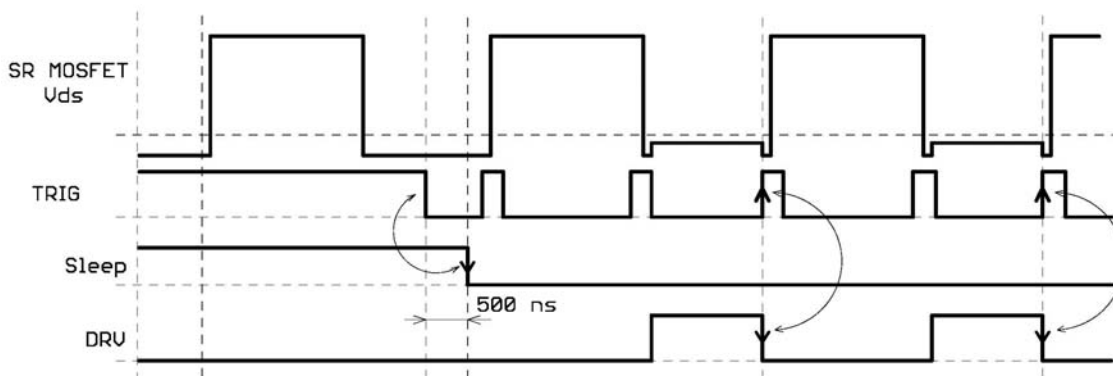
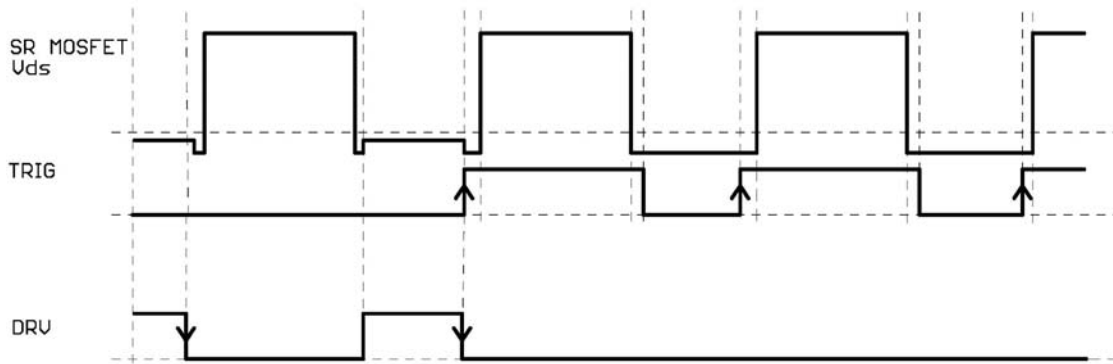

Figure 45. Operating Waveforms for the Trig/Disable Input –Wake-up from Sleep Mode

If the trigger signal comes periodically and the trigger pulse overlaps the SR MOSFET drain positive voltage (i.e. overlaps the whole SR MOSFET body diode off time

period), the driver is disabled for the next cycle – refer to Figure 46.

## NCP4303A, NCP4303B



**Figure 46. Operating Waveforms for the Trig/Disable Input with a Trigger Signal that is Periodical and Overlaps CS (SR MOSFET Vds) High Level**

Note that the trigger input is an ultrafast input that doesn't feature any internal filtering and reacts even on very narrow voltage pulses. Thus it is wise to keep this input on a low impedance path and provide it with a clean triggering signal.

A typical application schematic of a flyback converter that is operated in deep CCM mode can be seen in Figure 47. In this application the trigger signal is taken directly from the flyback controller driver output and transmitted to the secondary side by pulse transformer TR2. Because the trigger input is rising edge sensitive, it is not necessary to transmit the entire primary driver pulse to the secondary. The coupling capacitor C5 is used to allow pulse transformer core reset and also to prepare a needle pulse (a pulse with width lower than 100 ns) to be transmitted to the NCP4303 trigger input. The advantage of needle trigger pulse usage is that the required volt-second product of the pulse transformer is very low and that allows the designer to use very small and cheap magnetics. The trigger transformer can

be for instance prepared on a small toroidal ferrite core with diameter of 8 mm. Proper safety insulation between primary and secondary sides can be easily assured by using triple insulated wire for one or even both windings.

The primary MOSFET gate voltage rising edge is delayed by external circuitry consisting of transistors Q1, Q2 and surrounding components. The primary MOSFET is thus turned-on with a slight delay so that the secondary controller turns-off the SR MOSFET by trigger signal prior to the primary switching. This method reduces the commutation losses and the SR MOSFET drain voltage spike, which results in improved efficiency.

It is also possible to use capacitive coupling (use additional capacitor with safety insulation) between the primary and secondary to transmit the trigger signal. We do not recommend this technique as the parasitic capacitive currents between primary and secondary may affect the trigger signal and thus overall system functionality.

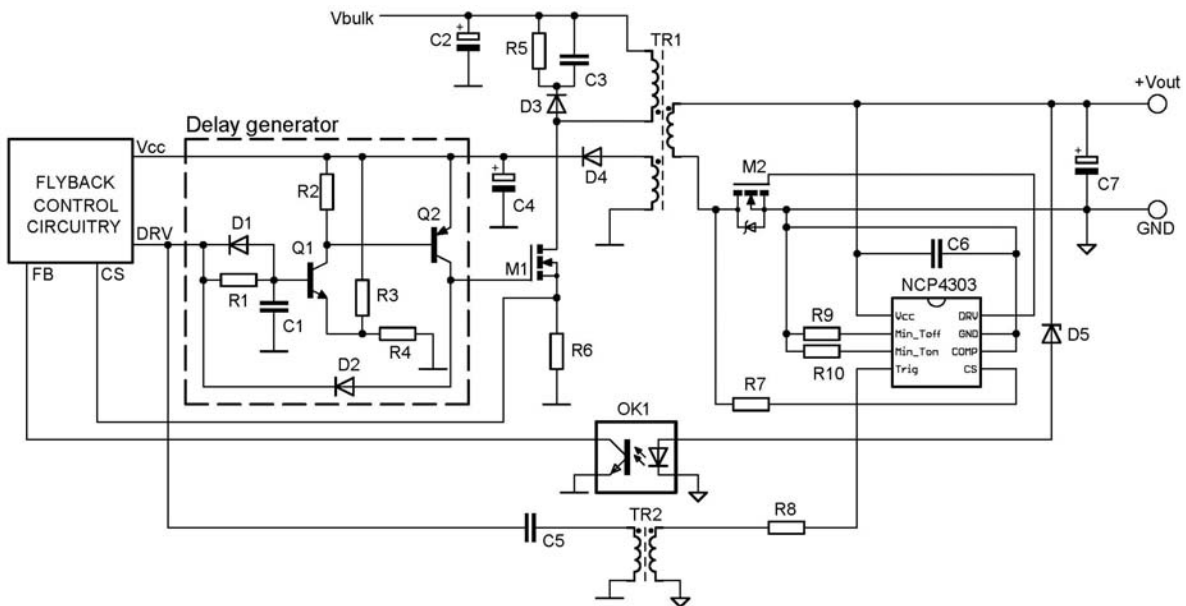
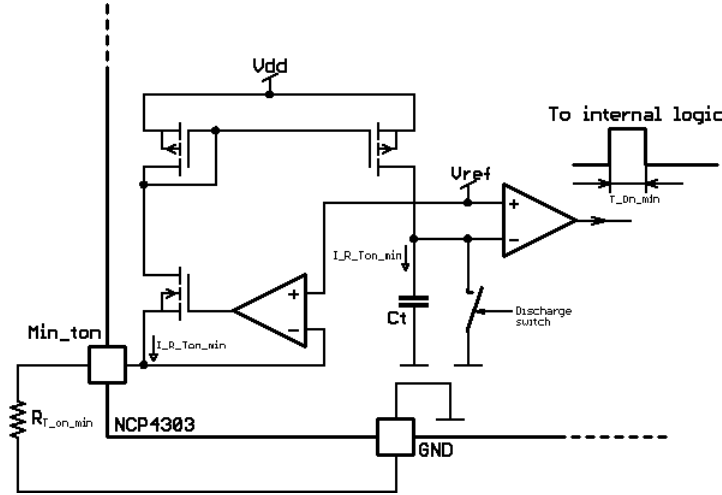

**Figure 47. Optional Application Schematic When NCP4303 is Used in CCM Flyback Converter and Trigger Input is Implemented to Maximize Efficiency**

**Minimum T<sub>on</sub> and T<sub>off</sub> Adjustment**

The NCP4303 offers adjustable minimum ON and OFF time periods that ease the implementation of the synchronous rectification system in a power supply. These

timers avoid false triggering on the CS input after the MOSFET is turned on or off. The adjustment is based on an internal timing capacitance and external resistors connected to the GND pin – refer to Figure 48 for better understanding.



**Figure 48. Internal Connection of the Min\_Ton Generator (the Min\_Toff Works in the Same Way)**

Current through the Min\_Ton adjust resistor can be calculated as:

$$I_{R\_Ton\_min} = \frac{V_{ref}}{R_{Ton\_min}} \quad (\text{eq. 4})$$

As the same current is used for the internal timing capacitor (Ct) charging, one can calculate the minimum on-time duration using this equation.

$$T_{on\_min} = C_t \cdot \frac{V_{ref}}{I_{R\_Ton\_min}} = C_t \cdot \frac{V_{ref}}{\frac{V_{ref}}{R_{Ton\_min}}} \quad (\text{eq. 5})$$

$$= C_t \cdot R_{Ton\_min}$$

As can be seen from Equation 5, the minimum ON and OFF times are independent of the V<sub>ref</sub> or V<sub>CC</sub> level. The

internal capacitor size would be too high if we would use directly I<sub>R\_Ton\_min</sub> current thus this current is decreased by the internal current mirror ratio. One can then calculate the minimum T<sub>on</sub> and T<sub>off</sub> blanking periods using below equations:

$$T_{on\_min} = 9.82 \cdot 10^{-11} \cdot R_{T\_on\_min} + 4.66 \cdot 10^{-8} \text{ [}\mu\text{s]} \quad (\text{eq. 6})$$

$$T_{off\_min} = 9.56 \cdot 10^{-11} \cdot R_{T\_off\_min} + 5.397 \cdot 10^{-8} \text{ [}\mu\text{s]} \quad (\text{eq. 7})$$

Note that the internal timing comparator delay affects the accuracy of Equations 6 and 7 when T<sub>on</sub>/T<sub>off</sub> times are selected near to their minimum possible values. Please refer to Figure 49 and 50 for measured minimum on and off time charts.

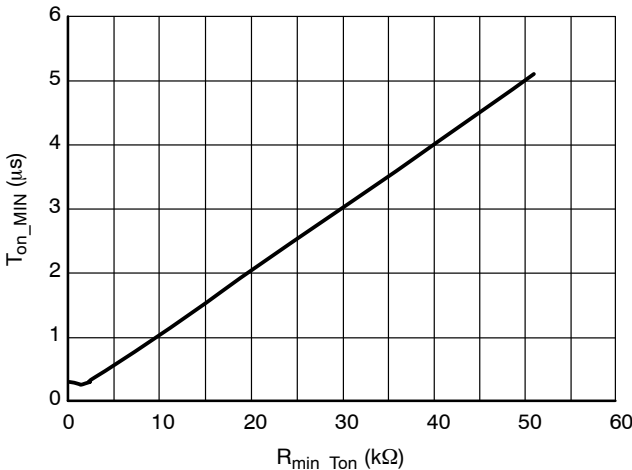

**Figure 49. Min T<sub>on</sub> Adjust Characteristic**

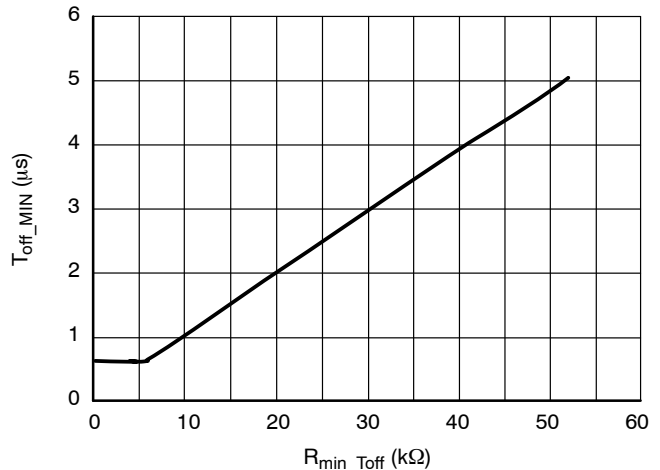

**Figure 50. Min T<sub>off</sub> Adjust Characteristic**



Note that  $R_{\text{drain1}}$  and  $R_{\text{drain2}}$  should be designed in such a way that the maximum pulse current into the Min\_Toff adjust pin is below 10 mA. Voltage on the min Toff and Ton pins is clamped by internal zener protection to 10 V.

### Power Dissipation Calculation

It is important to consider the power dissipation in the MOSFET driver of a SR system. If no external gate resistor is used and the internal gate resistance of the MOSFET is very low, nearly all energy losses related to gate charge are dissipated in the driver. Thus it is necessary to check the SR driver power losses in the target application to avoid over temperature and to optimize efficiency.

In SR systems the body diode of the SR MOSFET starts conducting before turn on because the  $V_{\text{th\_cs\_on}}$  threshold level is below 0 V. On the other hand, the SR MOSFET turn

off process always starts before the drain to source voltage rises up significantly. Therefore, the MOSFET switch always operates under Zero Voltage Switching (ZVS) conditions when implemented in a synchronous rectification system.

The following steps show how to approximately calculate the power dissipation and DIE temperature of the NCP4303A/B controller. Note that real results can vary due to the effects of the PCB layout on the thermal resistance.

### Step 1 – MOSFET gate to source capacitance:

During ZVS operation the gate to drain capacitance does not have a Miller effect like in hard switching systems because the drain to source voltage is close to zero and its change is negligible.

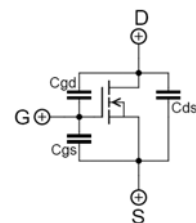
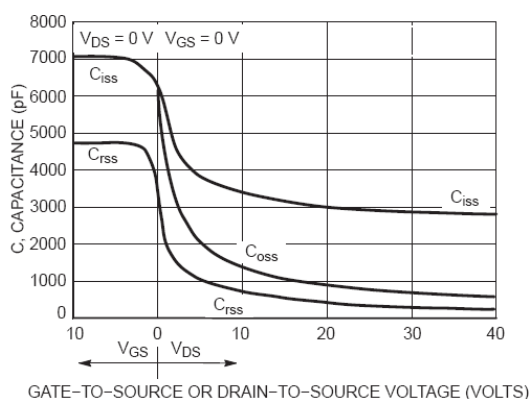

$$C_{\text{iss}} = C_{\text{gs}} + C_{\text{gd}}$$

$$C_{\text{rss}} = C_{\text{gd}}$$

$$C_{\text{oss}} = C_{\text{ds}} + C_{\text{gd}}$$

Figure 53. Typical MOSFET Capacitances Dependency on  $V_{\text{ds}}$  and  $V_{\text{gs}}$  Voltages

Therefore, the input capacitance of a MOSFET operating in ZVS mode is given by the parallel combination of the gate to source and gate to drain capacitances (i.e.  $C_{\text{iss}}$  capacitance for given gate to source voltage). The total gate charge,  $Q_{\text{g\_total}}$ , of most MOSFETs on the market is defined for hard switching conditions. In order to accurately calculate the driving losses in a SR system, it is necessary to determine the gate charge of the MOSFET for operation specifically in a ZVS system. Some manufacturers define this parameter as  $Q_{\text{g\_ZVS}}$ . Unfortunately, most datasheets do not provide this data. If the  $C_{\text{iss}}$  (or  $Q_{\text{g\_ZVS}}$ ) parameter is not available then it will need to be measured. Please note that the input capacitance is not linear (as shown Figure 53) and it needs to be characterized for a given gate voltage clamp level.

### Step 2 – Gate drive losses calculation:

Gate drive losses are affected by the gate driver clamp voltage. Gate driver clamp voltage selection depends on the type of MOSFET used (threshold voltage versus channel resistance). The total power losses (driving losses and conduction losses) should be considered when selecting the gate driver clamp voltage. Most of today's MOSFETs for SR systems feature low  $R_{\text{DS(on)}}$  for 5 V  $V_{\text{gs}}$  voltage and thus it

is beneficial to use NCP4303B. However, there is still a big group of MOSFETs on the market that require higher gate to source voltage – in this case the NCP4303A should be used.

The total driving loss can be calculated using the selected gate driver clamp voltage and the input capacitance of the MOSFET:

$$P_{\text{DRV\_total}} = V_{\text{CC}} \cdot V_{\text{clamp}} \cdot C_{\text{g\_ZVS}} \cdot f_{\text{SW}} \quad (\text{eq. 8})$$

Where:

$V_{\text{CC}}$  is the NCP4303x supply voltage

$V_{\text{clamp}}$  is the driver clamp voltage

$C_{\text{g\_ZVS}}$  is the gate to source capacitance of the MOSFET in ZVS mode

$f_{\text{SW}}$  is the switching frequency of the target application

The total driving power loss won't only be dissipated in the IC, but also in external resistances like the external gate resistor (if used) and the MOSFET internal gate resistance (Figure 54). Because NCP4303A/B features a clamped driver, its high side portion can be modeled as a regular driver switch with equivalent resistance and a series voltage source. The low side driver switch resistance does not drop

## NCP4303A, NCP4303B

immediately at turn-off, thus it is necessary to use an equivalent value ( $R_{drv\_low\_eq}$ ) for calculations. This method simplifies power losses calculations and still provides

acceptable accuracy. Internal driver power dissipation can then be calculated using Equation 9:

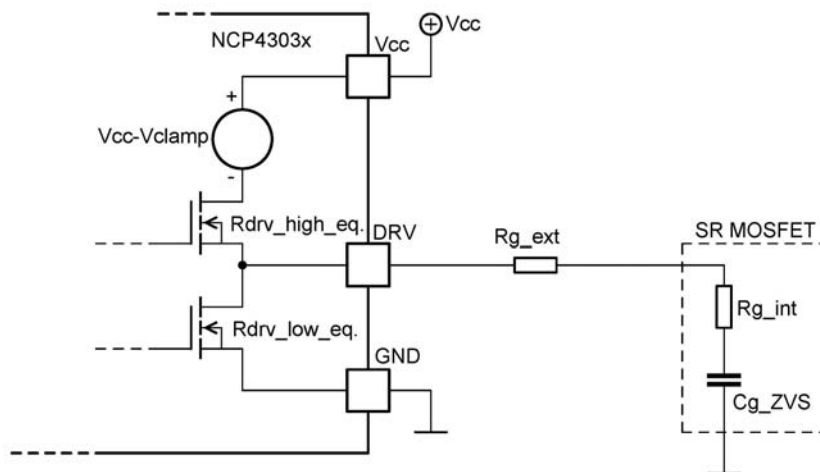

**Figure 54. Equivalent Schematic of Gate Drive Circuitry**

$$P_{DRV\_IC} = \frac{1}{2} \cdot C_{g\_ZVS} \cdot V_{clamp}^2 \cdot f_{SW} \cdot \left( \frac{R_{drv\_low\_eq}}{R_{drv\_low\_eq} + R_{g\_ext} + R_{g\_int}} \right) + C_{g\_ZVS} \cdot V_{clamp} \cdot f_{SW} \cdot (V_{CC} - V_{clamp}) \quad (\text{eq. 9})$$

$$+ \frac{1}{2} \cdot C_{g\_ZVS} \cdot V_{clamp}^2 \cdot f_{SW} \cdot \left( \frac{R_{drv\_high\_eq}}{R_{drv\_high\_eq} + R_{g\_ext} + R_{g\_int}} \right)$$

Where:

$R_{drv\_low\_eq}$  is the NCP4303x driver low side switch equivalent resistance (1.55  $\Omega$ )

$R_{drv\_high\_eq}$  is the NCP4303x driver high side switch equivalent resistance (7  $\Omega$ )

$R_{g\_ext}$  is the external gate resistor (if used)

$R_{g\_int}$  is the internal gate resistance of the MOSFET

### Step 3 – IC Consumption Calculation:

In this step, power dissipation related to the internal IC consumption is calculated. This power loss is given by the  $I_{CC}$  current and the IC supply voltage. The  $I_{CC}$  current depends on switching frequency and also on the selected min  $T_{on}$  and  $T_{off}$  periods because there is current flowing out from the min  $T_{on}$  and  $T_{off}$  pins. The most accurate method for calculating these losses is to measure the  $I_{CC}$  current when  $C_{load} = 0$  nF and the IC is switching at the target frequency with given Min\_Ton and Min\_Toff adjust resistors. Refer also to Figure 55 for typical IC consumption charts when the driver is not loaded. IC consumption losses can be calculated as:

$$P_{ICC} = V_{CC} \cdot I_{CC} \quad (\text{eq. 10})$$

### Step 4 – IC DIE Temperature Arise Calculation:

The DIE temperature can be calculated now that the total internal power losses have been determined (driver losses plus internal IC consumption losses). The SO-8 package thermal resistance is specified in the maximum ratings table for a 35  $\mu\text{m}$  thin copper layer with no extra copper plates on any pin (i.e. just 0.5 mm trace to each pin with standard soldering points are used).

The DIE temperature is calculated as:

$$T_{DIE} = (P_{DRV\_IC} + P_{ICC}) \cdot R_{\theta J-A} + T_A \quad (\text{eq. 11})$$

Where:

$P_{DRV\_IC}$  is the IC driver internal power dissipation

$P_{ICC}$  is the IC control internal power dissipation

$R_{\theta JA}$  is the thermal resistance from junction to ambient

$T_A$  is the ambient temperature

## NCP4303A, NCP4303B

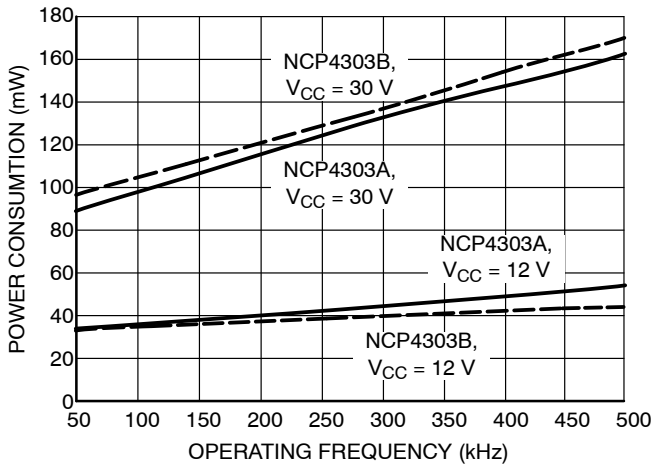

**Figure 55. IC Power Consumption as a Function of Frequency for  $C_{load} = 0$  nF,  $R_{ton\_min} = R_{toff\_min} = 5$  k $\Omega$**

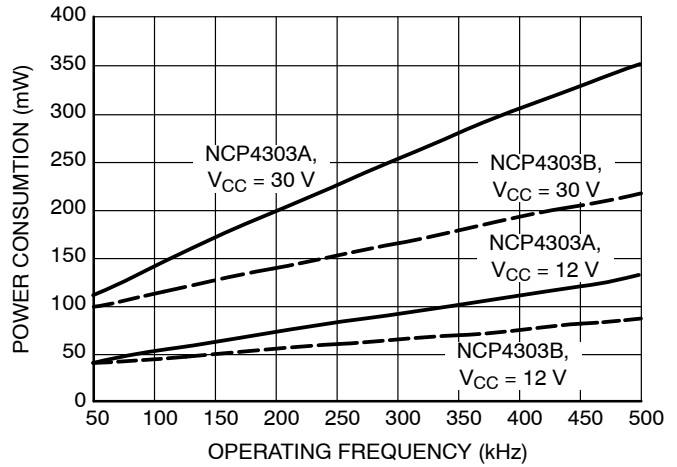

**Figure 56. IC Power Consumption as a Function of Frequency for  $C_{load} = 1$  nF,  $R_{ton\_min} = R_{toff\_min} = 5$  k $\Omega$**

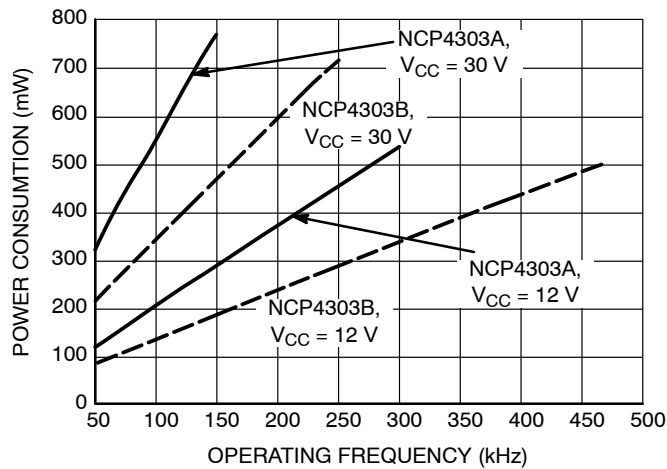
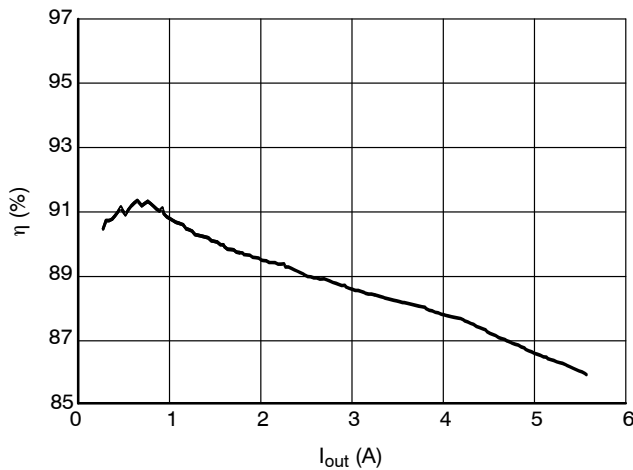

**Figure 57. IC Power Consumption as a Function of Frequency for  $C_{load} = 10$  nF,  $R_{ton\_min} = R_{toff\_min} = 5$  k $\Omega$**

### 65 W Adapter Design Example

This is wide range input application that uses NCP4303A. Application enters CCM mode for full load and  $V_{in} < 130$

Vac. Efficiency results measured on this application can be seen in Figures 58 and 59. Application schematic of the 12 V/5.5 A adapter can be seen in Figure 60.



**Figure 58.**

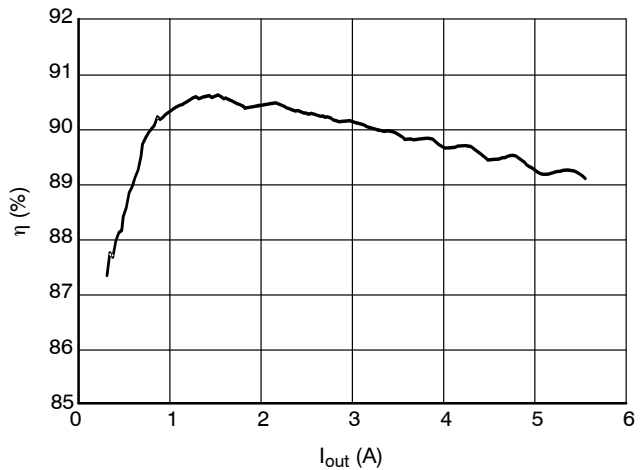

**Figure 59.**

# NCP4303A, NCP4303B

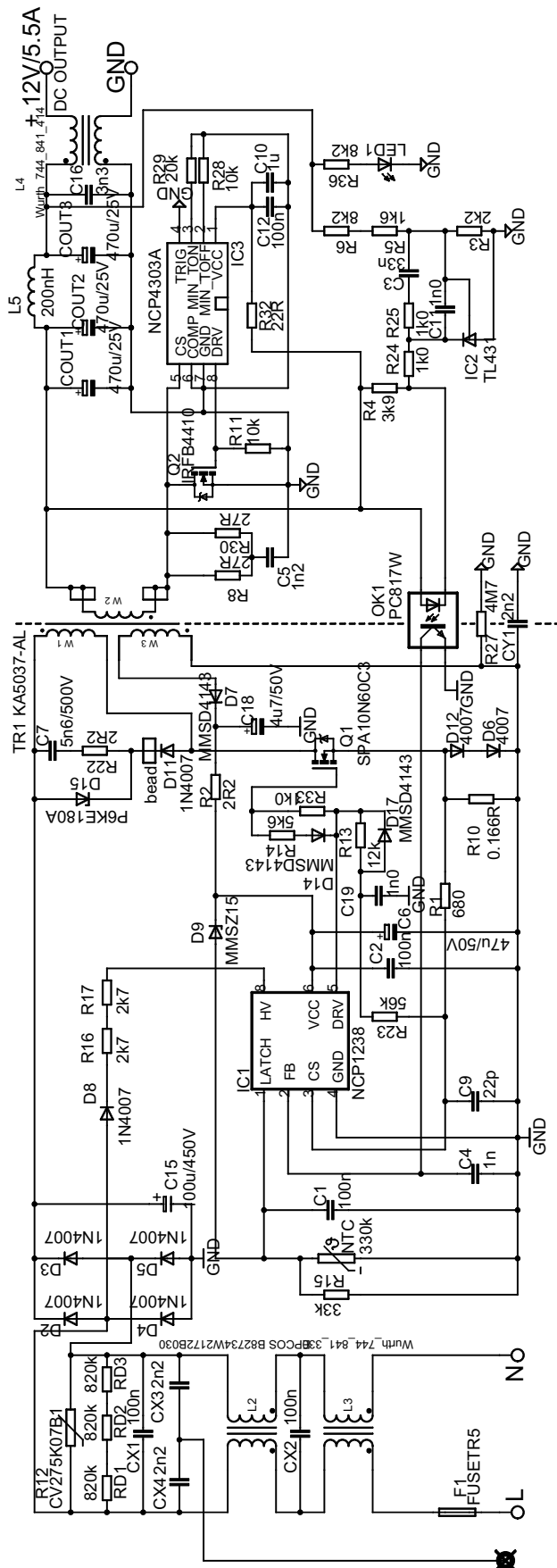

Figure 60. 65 W Adapter,  $V_{in} = 85 - 265 \text{ Vac}$ ,  $V_{out} = 12 \text{ V} / 5.5 \text{ A}$

# NCP4303A, NCP4303B

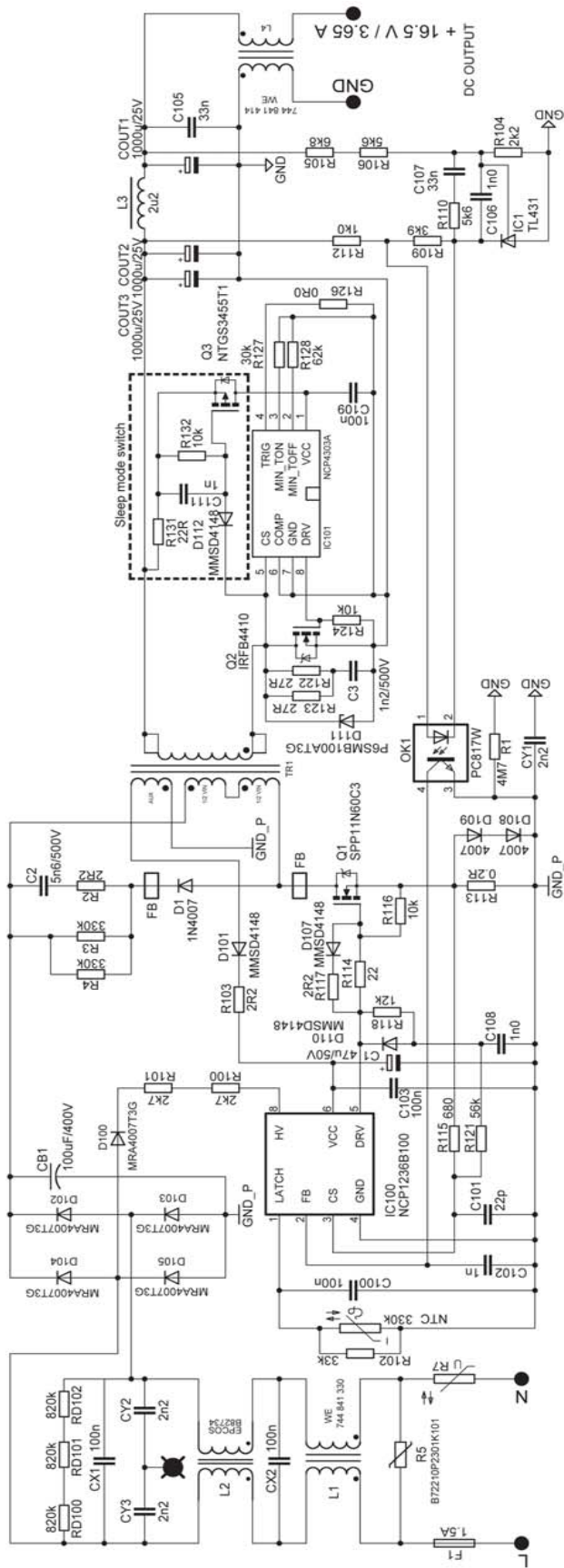
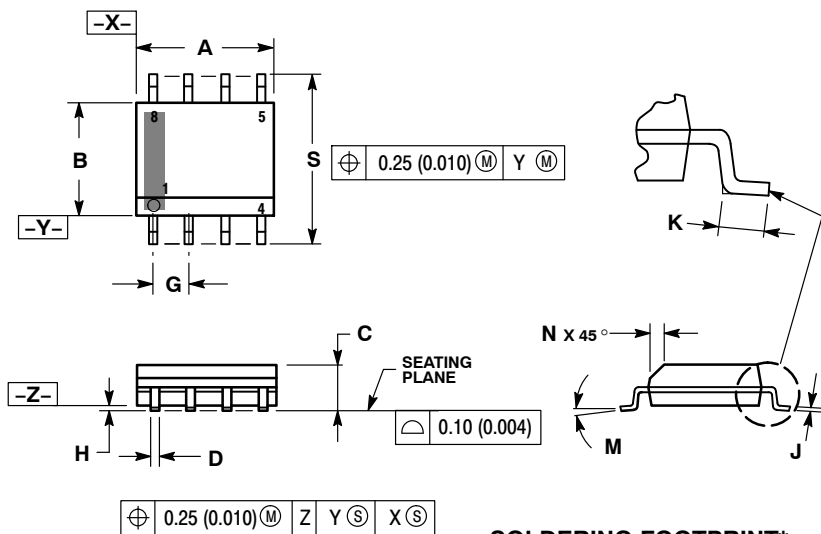

Figure 61. CCM Flyback Application with SR Sleep Mode Implemented via VCC Pin

# NCP4303A, NCP4303B

## PACKAGE DIMENSIONS

SOIC-8 NB  
CASE 751-07  
ISSUE AK



NOTES:

1. DIMENSIONING AND TOLERANCING PER ANSI Y14.5M, 1982.
2. CONTROLLING DIMENSION: MILLIMETER.
3. DIMENSION A AND B DO NOT INCLUDE MOLD PROTRUSION.
4. MAXIMUM MOLD PROTRUSION 0.15 (0.006) PER SIDE.
5. DIMENSION D DOES NOT INCLUDE DAMBAR PROTRUSION. ALLOWABLE DAMBAR PROTRUSION SHALL BE 0.127 (0.005) TOTAL IN EXCESS OF THE D DIMENSION AT MAXIMUM MATERIAL CONDITION.
6. 751-01 THRU 751-06 ARE OBSOLETE. NEW STANDARD IS 751-07.

DIM	MILLIMETERS		INCHES	
	MIN	MAX	MIN	MAX
A	4.80	5.00	0.189	0.197
B	3.80	4.00	0.150	0.157
C	1.35	1.75	0.053	0.069
D	0.33	0.51	0.013	0.020
G	1.27 BSC		0.050 BSC	
H	0.10	0.25	0.004	0.010
J	0.19	0.25	0.007	0.010
K	0.40	1.27	0.016	0.050
M	0°	8°	0°	8°
N	0.25	0.50	0.010	0.020
S	5.80	6.20	0.228	0.244

### SOLDERING FOOTPRINT\*



SCALE 6:1  $\left(\frac{\text{mm}}{\text{inches}}\right)$

\*For additional information on our Pb-Free strategy and soldering details, please download the ON Semiconductor Soldering and Mounting Techniques Reference Manual, SOLDERRM/D.

# NCP4303A, NCP4303B

## PACKAGE DIMENSIONS

DFN8 4x4  
CASE 488AF-01  
ISSUE C

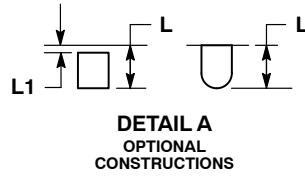
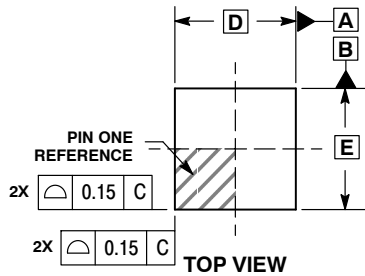

- NOTES:
1. DIMENSIONS AND TOLERANCING PER ASME Y14.5M, 1994.
  2. CONTROLLING DIMENSION: MILLIMETERS.
  3. DIMENSION b APPLIES TO PLATED TERMINAL AND IS MEASURED BETWEEN 0.15 AND 0.30MM FROM TERMINAL TIP.
  4. COPLANARITY APPLIES TO THE EXPOSED PAD AS WELL AS THE TERMINALS.
  5. DETAILS A AND B SHOW OPTIONAL CONSTRUCTIONS FOR TERMINALS.

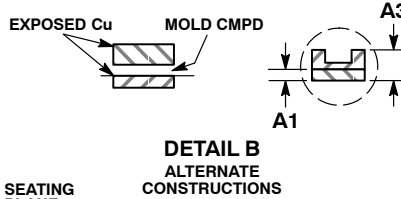
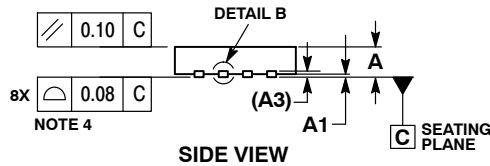

MILLIMETERS		
DIM	MIN	MAX
A	0.80	1.00
A1	0.00	0.05
A3	0.20	REF
b	0.25	0.35
D	4.00	BSC
E	1.91	2.21
E2	2.09	2.39
e	0.80	BSC
K	0.20	---
L	0.30	0.50
L1	---	0.15

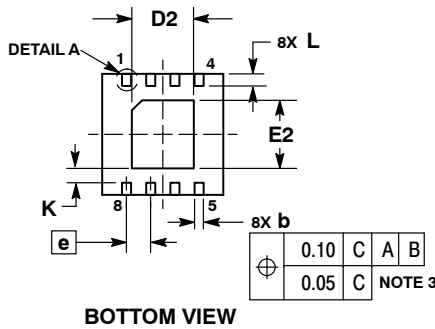

### SOLDERING FOOTPRINT\*

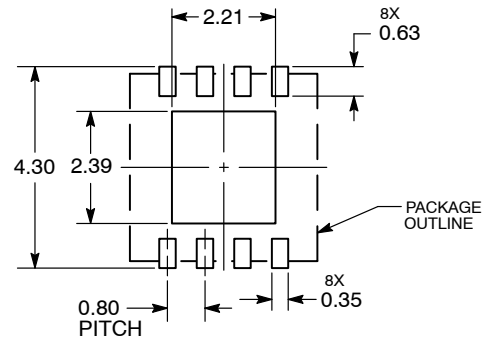

DIMENSIONS: MILLIMETERS

\*For additional information on our Pb-Free strategy and soldering details, please download the ON Semiconductor Soldering and Mounting Techniques Reference Manual, SOLDERRM/D.

ON Semiconductor and are registered trademarks of Semiconductor Components Industries, LLC (SCILLC). SCILLC reserves the right to make changes without further notice to any products herein. SCILLC makes no warranty, representation or guarantee regarding the suitability of its products for any particular purpose, nor does SCILLC assume any liability arising out of the application or use of any product or circuit, and specifically disclaims any and all liability, including without limitation special, consequential or incidental damages. "Typical" parameters which may be provided in SCILLC data sheets and/or specifications can and do vary in different applications and actual performance may vary over time. All operating parameters, including "Typicals" must be validated for each customer application by customer's technical experts. SCILLC does not convey any license under its patent rights nor the rights of others. SCILLC products are not designed, intended, or authorized for use as components in systems intended for surgical implant into the body, or other applications intended to support or sustain life, or for any other application in which the failure of the SCILLC product could create a situation where personal injury or death may occur. Should Buyer purchase or use SCILLC products for any such unintended or unauthorized application, Buyer shall indemnify and hold SCILLC and its officers, employees, subsidiaries, affiliates, and distributors harmless against all claims, costs, damages, and expenses, and reasonable attorney fees arising out of, directly or indirectly, any claim of personal injury or death associated with such unintended or unauthorized use, even if such claim alleges that SCILLC was negligent regarding the design or manufacture of the part. SCILLC is an Equal Opportunity/Affirmative Action Employer. This literature is subject to all applicable copyright laws and is not for resale in any manner.

### PUBLICATION ORDERING INFORMATION

**LITERATURE FULFILLMENT:**  
Literature Distribution Center for ON Semiconductor  
P.O. Box 5163, Denver, Colorado 80217 USA  
**Phone:** 303-675-2175 or 800-344-3860 Toll Free USA/Canada  
**Fax:** 303-675-2176 or 800-344-3867 Toll Free USA/Canada  
**Email:** orderlit@onsemi.com

**N. American Technical Support:** 800-282-9855 Toll Free  
USA/Canada  
**Europe, Middle East and Africa Technical Support:**  
Phone: 421 33 790 2910  
**Japan Customer Focus Center**  
Phone: 81-3-5773-3850

**ON Semiconductor Website:** [www.onsemi.com](http://www.onsemi.com)  
**Order Literature:** <http://www.onsemi.com/orderlit>  
For additional information, please contact your local Sales Representative



Компания «Life Electronics» занимается поставками электронных компонентов импортного и отечественного производства от производителей и со складов крупных дистрибьюторов Европы, Америки и Азии.

С конца 2013 года компания активно расширяет линейку поставок компонентов по направлению коаксиальный кабель, кварцевые генераторы и конденсаторы (керамические, пленочные, электролитические), за счёт заключения дистрибьюторских договоров

Мы предлагаем:

- Конкурентоспособные цены и скидки постоянным клиентам.
- Специальные условия для постоянных клиентов.
- Подбор аналогов.
- Поставку компонентов в любых объемах, удовлетворяющих вашим потребностям.
- Приемлемые сроки поставки, возможна ускоренная поставка.
- Доставку товара в любую точку России и стран СНГ.
- Комплексную поставку.
- Работу по проектам и поставку образцов.
- Формирование склада под заказчика.
- Сертификаты соответствия на поставляемую продукцию (по желанию клиента).
- Тестирование поставляемой продукции.
- Поставку компонентов, требующих военную и космическую приемку.
- Входной контроль качества.
- Наличие сертификата ISO.

В составе нашей компании организован Конструкторский отдел, призванный помогать разработчикам, и инженерам.

Конструкторский отдел помогает осуществить:

- Регистрацию проекта у производителя компонентов.
- Техническую поддержку проекта.
- Защиту от снятия компонента с производства.
- Оценку стоимости проекта по компонентам.
- Изготовление тестовой платы монтаж и пусконаладочные работы.



Тел: +7 (812) 336 43 04 (многоканальный)  
Email: [org@lifeelectronics.ru](mailto:org@lifeelectronics.ru)