

# Advanced 12 Channel Constant Current LED Driver IC



## BD18378EFV-M

### General Description

The BD18378EFV-M is a serial input controlled constant current LED driver with 8 V output rating. 6 bit current calibration is available for each output while a selected PWM input performs dimming on the corresponding output. The BD18378EFV-M is able to perform diagnostic (open / short / temperature) checks to detect LED failure and over temperature on chip. Fault detection is performed also during LED deactivated state. The settings of all internal registers can be read out to verify written information at any time.

### Features

- AEC-Q100 Qualified (Note1)
  - Current capability: 50mA per output channel.
  - 4-line SPI Control.
  - External resistor current setting.
  - Limp Home capability.
  - PWM dimming 0.2-99.2% at 200Hz
  - Diagnostic of all PWM inputs.
  - Programmable output mapping to each PWM input.
  - 6 Bit LED brightness adjustment on each channel.
  - Diagnostic output on LED OPEN and SHORT for each channel during PWM on & off time.
  - True LED voltage measurement.
  - Over Temperature Protection and Thermal Feedback.
  - Open Drain Fault indicator.
  - Read-back of all register settings.
  - Outputs can be connected in parallel to achieve more than 50mA into the load.
  - Slew Rate limited switching reduces radiated Noise (EMI).
  - Daisy chain compatible.
- (Note1: Operating Temperature Grade 2)

### Key Specifications

- Input voltage range: 3V to 5.5V
- Output voltage range: 0.5V to 8V
- Output Current range: 10mA to 50mA
- Output Current accuracy: 3.5%
- Maximum clock frequency: 1.25MHz
- Operating current: 4mA (Typ.)
- Operating temperature range: - 40°C to +105°C

### Package

HTSSOP-B28

L(Typ.) x W(Typ.) x H(Max.)  
9.70mm x 6.40mm x 1.00mm

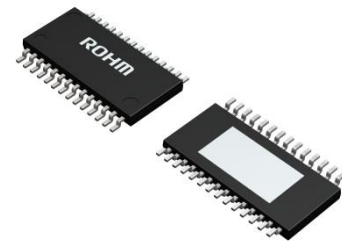

### Applications

- Automotive illumination & ambient light
- Consumer electronics illumination

### Typical Application Circuit Diagram

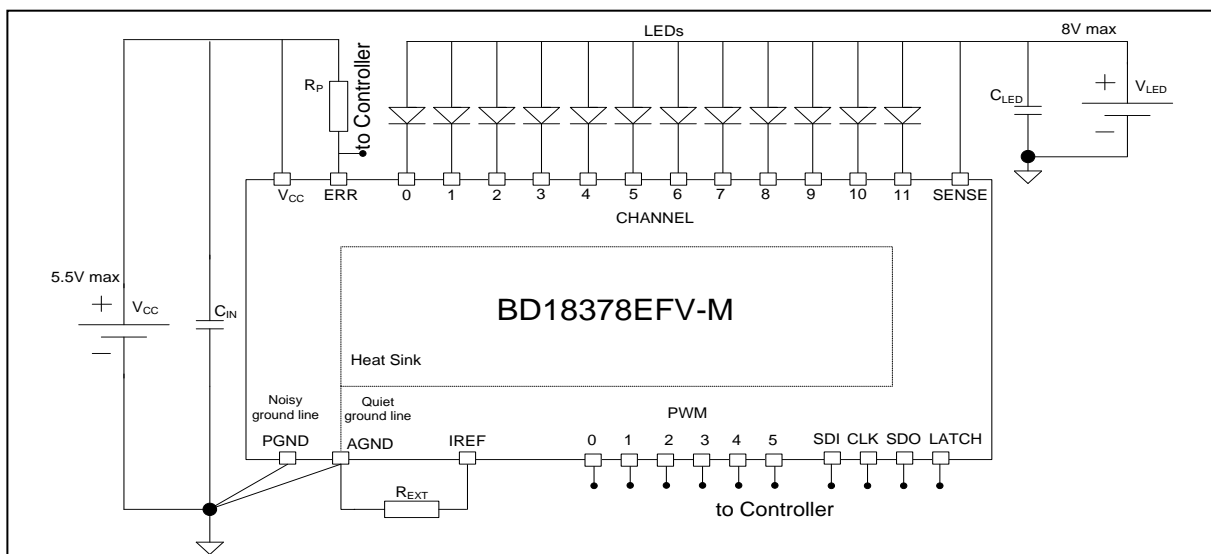

Figure 1. Typical application diagram

## Pin Configuration

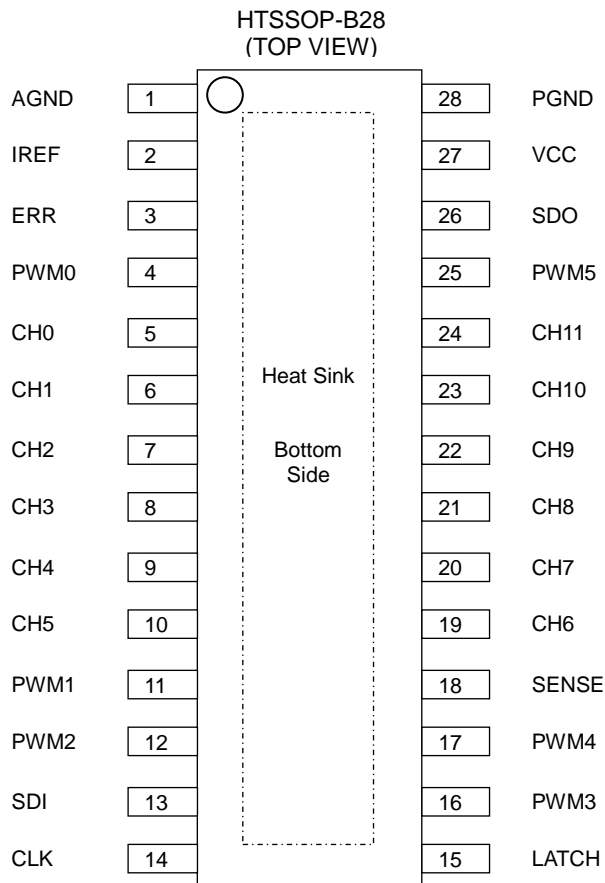

Figure 2. Pin Configuration

## Pin Description

Pin No.	Symbol	Function	Pin No.	Symbol	Function
1	AGND	Analog ground terminal	28	PGND	Power ground terminal
2	IREF	Current setting terminal	27	VCC	Power supply terminal
3	ERR	Open drain fault indicator	26	SDO	Serial data output terminal
4	PWM0	PWM 0 input terminal	25	PWM5	PWM 5 input terminal
5	CH0	Output channel 0	24	CH11	Output channel 11
6	CH1	Output channel 1	23	CH10	Output channel 10
7	CH2	Output channel 2	22	CH9	Output channel 9
8	CH3	Output channel 3	21	CH8	Output channel 8
9	CH4	Output channel 4	20	CH7	Output channel 7
10	CH5	Output channel 5	19	CH6	Output channel 6
11	PWM1	PWM 1 input terminal	18	SENSE	LED supply sensing terminal
12	PWM2	PWM 2 input terminal	17	PWM4	PWM 4 input terminal
13	SDI	Serial data input terminal	16	PWM3	PWM 3 input terminal
14	CLK	Serial communication clock	15	LATCH	Latch signal input terminal

## Absolute Maximum Ratings

Item	Symbol	Absolute Maximum value	Unit
Power Supply Voltage(Pin No: 27)	V <sub>CC</sub>	7	V
Output Voltage (Pin No: 5 to 9, 19 to 24)	V <sub>Dmax</sub>	10	V
Input Voltage (Pin No: 4,11 to 17, 25)	V <sub>IN</sub>	-0.3 to V <sub>CC</sub>	V
Open Drain Fault Indicator(Pin No: 3)	V <sub>ERR</sub>	7	V
Operating Temperature Range	T <sub>OPR</sub>	-40 to +105	°C
Storage Temperature Range	T <sub>STG</sub>	-55 to +150	°C
Junction Temperature	T <sub>Jmax</sub>	150	°C
LED Voltage(Pin No: 18)	V <sub>SENSE</sub>	10	V
Electrostatic-Discharge Capability Human Body Model	ESD HBM	2000	V
Electrostatic-Discharge Capability Machine Model	ESD MM	200	V
PWM duty cycle	PWM	100	%

## Recommended Operating Ratings

Item	Symbol	Standard Value			Unit
		Min	Typ	Max	
Power Supply Voltage	V <sub>CC</sub>	3.0	-	5.5	V
Drive Current at full brightness*1	I <sub>D</sub>	10	30	50	mA
Output Voltage*1	V <sub>D</sub>	-	-	8	V
LED Voltage*1*3	V <sub>SENSE</sub>	-	-	8	V
Open Drain Fault Indicator	V <sub>ERR</sub>	-	-	5.5	V
PWM duty cycle*2	PWM	0.2	-	99.2	%

\*1 Check Power de-rating curves of the package before applying maximum values.

\*2 99.2% max and 0.2% min duty cycle at a 200Hz PWM frequency is recommended in order to have complete diagnostic capability; please note that the PWM signal is active LOW.

\*3 Please make sure the V<sub>SENSE</sub> voltage is always connected to the LEDs supply voltage - at a higher potential than V<sub>D</sub>. (see also the I/O equivalent circuits)

Thermal Information<sup>\*4</sup>

Item	Symbol	Value	Unit
Junction to Ambient Thermal Resistance (1 layer Board)	θ <sub>JA</sub>	107	°C/W
Junction to TOP Thermal characterization Parameter (1 layer Board)	ψ <sub>JT</sub>	6	°C/W
Junction to Ambient Thermal Resistance (4 layer Board)	θ <sub>JA</sub>	26	°C/W
Junction to TOP Thermal characterization Parameter (4 layer Board)	ψ <sub>JT</sub>	3	°C/W
Junction to Case Thermal Resistance	θ <sub>JC-TOP</sub>	13	°C/W
Junction to Case Thermal Resistance	θ <sub>JC-BOT</sub>	4	°C/W

\*4 Measured as per JEDEC Standard

Board as per JESD51-3/-5/-7

Environment as per JESD51-2A

The above mentioned data is measurement data to be used only as reference not guaranteed values.



- **Protection circuitry and diagnostic**

- **LED Short Detection**

A short event is detected when the voltage across the LED falls below the short detection threshold  $V_{SCh}$ . The SHORT detection current which is flowing during LED active (PWM = "LOW"), will cause a typical output current offset of  $20\mu A$ . After a detected LED short event, the corresponding bit of the Gen\_SHORT detection register and the ANY\_SHORT\_OPEN\_FLAG from the STATUS register remain high until cleared by the controller. The SHORT detection is also performed, when the LED is not activated, using small sink currents for small time intervals (20us) to avoid LED flicker. In order for the detection to be available at non-activated LED state the PWM duty cycle must be  $<99.2\%$  at a frequency of 200Hz.

- **LED Open Detection**

During an open event the output device will be fully ON, pulling  $V_{Dx}$  low. An open event is detected when voltage  $V_{Dx}$  at the output pin falls below  $V_{Oth}$ . The OPEN detection current,  $I_{pull\ down}$  which is flowing during LED active (PWM = "LOW"), will cause a typical output current offset of  $20\mu A$ . After a LED open event has been detected the corresponding bit of the Gen\_OPEN detection register and ANY\_SHORT\_OPEN\_FLAG from the STATUS register remain high until cleared by the controller. The OPEN detection is also performed, when the LED is not activated, using small sink currents for small time intervals (20us) to avoid LED flicker. In order for the detection to be available at non-activated LED state the PWM duty cycle must be  $<99.2\%$  at a frequency of 200Hz.

**Note:** In order to distinguish between diagnostics (LED Short Detection and LED Open Detection) at ON and OFF, the corresponding detection must be enabled and corresponding state of the channel must be checked (enabled/disabled).

- **Short to Ground Detection**

The chip can perform output short to ground diagnosis during non-activated LED state. After LED short and open at channel off diagnosis, a short to ground can be also detected. In order for the detection to be available at non-activated LED state the PWM duty cycle must be  $<99.2\%$  at a frequency of 200Hz.

The diagnostic is activated or deactivated by the EN\_SHORT\_TO\_GND register.

After an output short to ground has been detected the corresponding bit of the SHORT\_TO\_GND detection register and ANY\_SHORT\_TO\_GND\_FLAG from the STATUS register remain high until cleared by the controller.

**Note:** In case both the Open Detection and Short to GND Detection are active at the same time and the voltage  $V_{Dx}$  at the output pin falls below  $V_{SGth}$  also the corresponding bit of the Gen\_OPEN detection register and ANY\_SHORT\_OPEN\_FLAG from the STATUS register remain high until cleared by the controller.

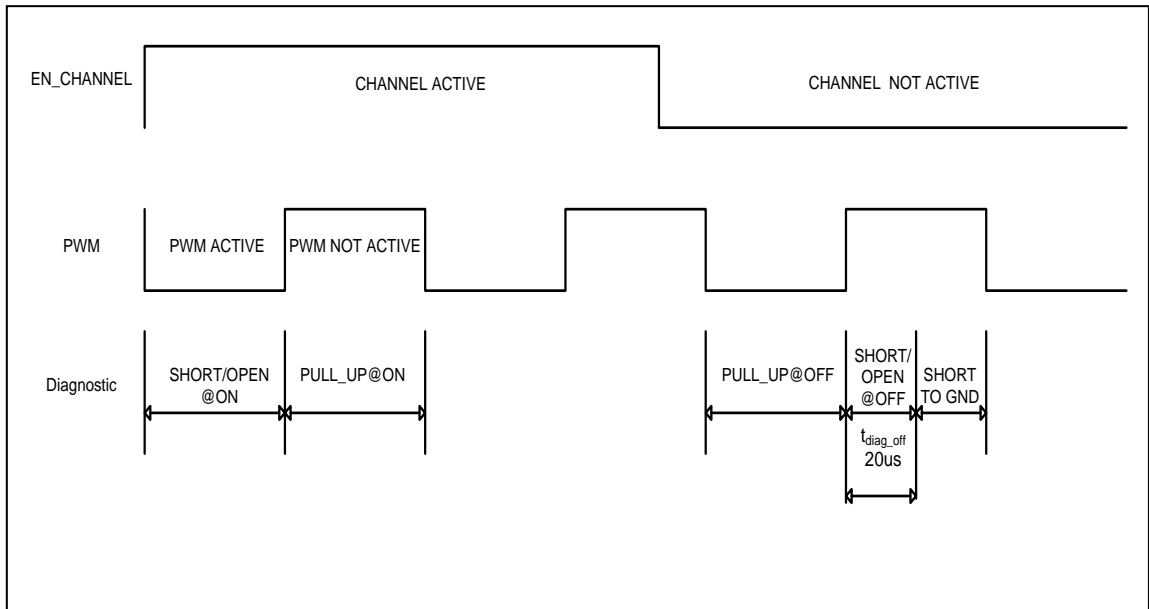

Figure 4. Diagnostic diagram

- **I<sub>REF</sub> Fault Detection (Limp Home functionality)**

The chip can perform I<sub>REF</sub> short and open diagnostic on the external resistor. In case of an error the REXT\_FAULT flag is set and latched and an internal current reference is used to set a typical output current of I<sub>REF\_LH</sub>. If the fault condition is removed the chip can be reset to the normal operating state by a POR event.

- **PWM Fault Detection**

PWM fault diagnostic can be performed at startup to test for wire connectivity. The chip is initialized with a PWM fault condition that changes to PWM\_OK immediately after the first falling edge on the PWM input(s).

- **UVLO Under Voltage LockOut**

By monitoring the Vcc pin an UVLO event can be detected. If Vcc is below UVLO\_L then the chip is turned off. If the Vcc voltage increases over the UVLO\_H threshold then the chip is turned back on.

- **Weak LED Supply Voltage Detection**

By monitoring VSENSE pin, a low LED supply voltage can be detected. After a Weak LED Supply voltage has been detected a corresponding one bit register flag is set and remains high until cleared by the controller. The detection has its own status bit and is mapped to Open Drain Fault Indicator. Note that this circuit is always active. A masking command that can be locked and read back is implemented.

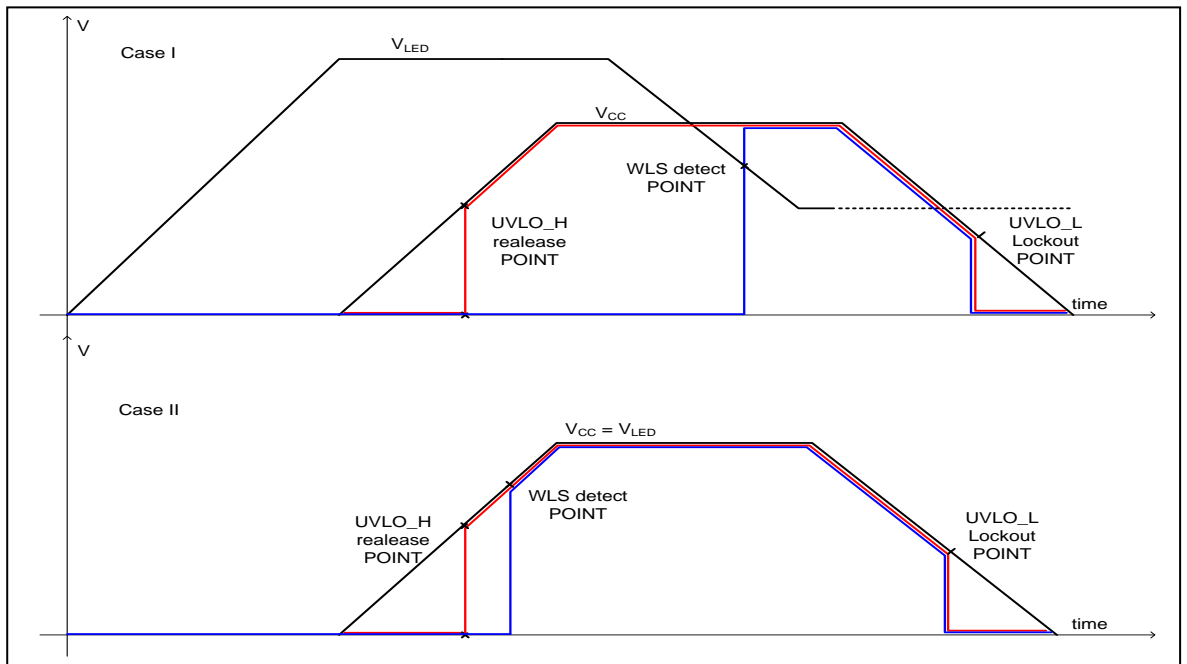

Figure 5. Startup diagram

**Note:** In Case II when the MASK\_WLS will be activated a Weak LED Supply event will be signaled to the internal logic. This is because the detection circuit itself is not disabled by the MASK\_WLS command but only the diagnostic is masked.

- **Open Drain Fault Indicator**

An emergency warning pin is available (ERR) to signal to the controller the most important faults of the system. The ERR output is activated (active="LOW") when a fault flag in the STATUS register or a flag in the UNLOCK register is set. The flags can be masked using the WRITE\_EN\_ERR\_PIN command. The content of the EN\_ERR\_PIN register shows the flags that will activate the Open Drain Fault Indicator (ERR). The picture below shows the ERR pin functionality:

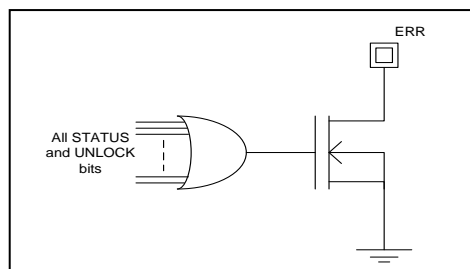

Figure 6. Open Drain fault indicator (ERR)

- **Over temperature**

- TSD130°C:*

- When the die temperature exceeds 130°C a warning flag is set and latched. The controller can take action to reduce power. A hysteresis of 10°C is implemented from the point where the warning flag is set until the warning is released.

- The chip functionality is not changed.

- TSD180°C:*

- When the die temperature exceeds 180°C, the driver disables the output currents. The logic remains functional and the controller is still able to read the status. This allows the controller to take action and avoid a repeated thermal shutdown.

- A hysteresis of 10°C is implemented from the point where the warning flag is set until the warning is released. If the temperature drops below the hysteresis value then the device will resume its previously set functionality.

- **POR (Power ON Reset)**

A POR event can occur in one of the following situations:

1. Low supply voltage at Startup or UVLO (Under Voltage LockOut).
2. When the controller sends a command SOFTWARE\_POR (Software Reset)

- **POR at Startup or UVLO**

- At startup, which is defined here as first application of supply voltage VCC, or when VCC recovers from an under voltage event, a POR will occur.

- The ERR pin will be set to LOW and the POR\_FLAG is set HIGH. All registers are set to default values.

- **POR SWR (SPOR)**

- The controller can send a reset command SOFTWARE\_POR.

- The POR flag in the STATUS register is set HIGH. All registers are set to default values. The ERR pin will be set LOW.

## Description of Commands

Command [WRITE\_PWM\_MAPx] is used to assign for each channel output one single PWM input.

Command [READ\_PWM\_MAPx] is used to read back the data and ensure it was received correctly.

Command [WRITE\_CALx] is used to set the calibration of each output during operation.

Command [READ\_CALx] is used to read back the data and ensure it was received correctly.

Command [WRITE\_EN\_CHANNEL] is used to enable/disable the output channels.

Command [READ\_EN\_CHANNEL] is used to read back the data to ensure it was received correctly.

Command [WRITE\_EN\_SHORT@ON] is used to enable/disable the short detection at channel on.

Command [READ\_EN\_SHORT@ON] is used to read back the data to ensure it was received correctly.

Command [WRITE\_EN\_OPEN@ON] is used to enable/disable the open detection at channel on.

Command [READ\_EN\_OPEN@ON] is used to read back the data to ensure it was received correctly.

Command [WRITE\_EN\_SHORT@OFF] is used to enable/disable the short detection at channel off.

Command [READ\_EN\_SHORT@OFF] is used to read back the data to ensure it was received correctly.

Command [WRITE\_EN\_OPEN@OFF] is used to enable/disable the open detection at channel off.

Command [READ\_EN\_OPEN@OFF] is used to read back the data to ensure it was received correctly.

Command [WRITE\_EN\_SHORT\_TO\_GND] is used to enable/disable the short to ground fault detection.

Command [READ\_EN\_SHORT\_TO\_GND] is used to read back the data to ensure it was received correctly.

Command [WRITE\_EN\_PULL\_UP@ON] is used to enable/disable the pull up current at channel on.

Command [READ\_EN\_PULL\_UP@ON] is used to read back the data to ensure it was received correctly.

Command [WRITE\_EN\_PULL\_UP@OFF] is used to enable/disable the pull up current at channel off.

Command [READ\_EN\_PULL\_UP@OFF] is used to read back the data to ensure it was received correctly.

Command [WRITE\_EN\_ERR] is used to enable/disable the bits that activate the emergency warning pin.

Command [READ\_EN\_ERR] is used to read back the data to ensure it was received correctly.

Command [WRITE\_MASK\_WLS] is used to mask/unmask the weak LED supply detection.

Command [READ\_MASK\_WLS] is used to read back data to ensure it was received correctly.

Command [WRITE\_LOCK] is used to lock the important registers.

Command [WRITE\_UNLOCK] is used to unlock the important registers.

Command [READ\_UNLOCK] is used to read back the data to ensure it was received correctly.

Command [RESET\_STATUS] can reset all bits in the STATUS register except for the REXT\_FAULT\_FLAG, based on command parameters, and resets the PWM\_OK register (see RESET\_STATUS command description).

Command [READ\_STATUS] is used to access all bits in the STATUS register.

Command [SOFTWARE\_POR] resets the chip and sets all registers to default values. POR\_FLAG is set HIGH.

Command [READ\_PWM\_OK] is used to read the PWM detection.

Command [READ\_Gen\_SHORT] is used to read the LED short detection.

Command [READ\_Gen\_OPEN] is used to read the LED open detection.

Command [READ\_SHORT\_TO\_GND] is used to read the short to ground detection.

- **WRITE\_PWM\_MAP command & READ\_PWM\_MAP command:**

Register Name	Address	Data Code<7:0>								Comments
PWM_MAP <sub>k</sub>	40 to 45	b7	b6	b5	b4	b3	b2	b1	b0	Assign CH <sub>2k+1</sub> and CH <sub>2k</sub> to PWM <sub>x</sub> , k=0 to 5
PWM_MAP <sub>k</sub>	80 to 85	b7	b6	b5	b4	b3	b2	b1	b0	Read CH <sub>2k+1</sub> and CH <sub>2k</sub> to PWM <sub>x</sub> , k=0 to 5

- Code:

8bit CMD (for all channels)	Data<7:4>or<3:0>
PWM0	0000
PWM1	0001
PWM2	0010
PWM3	0011
PWM4	0100
PWM5	0101
PWM0 Default for invalid data	0110 to 1111

- **WRITE\_CALx command & READ\_CALx command (where x = 0 to 11):**

Register Name	Address	Data Code<7:0>								Comments
CALx	48 to 53	x	x	b5	b4	b3	b2	b1	b0	Write calibration setting of CH0 to CH11
CALx	88 to 93	u	u	b5	b4	b3	b2	b1	b0	Read calibration setting of CH0 to CH11

- Code:

1=enable Cal bit  
0=disable Cal bit  
x=don't care  
u=unchanged

- **WRITE\_EN\_CHANNEL command & READ\_EN\_CHANNEL command:**

Register Name	Address	Data Code<7:0>								Comments
EN_CHANNEL	56	x	x	b5	b4	b3	b2	b1	b0	Enable Channel CH5 to CH0
EN_CHANNEL	57	x	x	b11	b10	b9	b8	b7	b6	Enable Channel CH11 to CH6
EN_CHANNEL	96	u	u	b5	b4	b3	b2	b1	b0	Read Enable Channel CH5 to CH0
EN_CHANNEL	97	u	u	b11	b10	b9	b8	b7	b6	Read Enable Channel CH11 to CH6

- Code:

1=enable Channel  
0=disable Channel  
x=don't care  
u=unchanged



- **WRITE\_EN\_SHORT@ON command & READ\_EN\_SHORT@ON:**

Register Name	Address	Data Code<7:0>								Comments
EN_SHORT@ON	58	x	x	b5	b4	b3	b2	b1	b0	Enable Short@on CH5 to CH0
EN_SHORT@ON	59	x	x	b11	b10	b9	b8	b7	b6	Enable Short@on CH11 to CH6
EN_SHORT@ON	98	u	u	b5	b4	b3	b2	b1	b0	Read Enable Short@on CH5 to CH0
EN_SHORT@ON	99	u	u	b11	b10	b9	b8	b7	b6	Read Enable Short@on CH11 to CH6

- Code:
  - 1=enable Short
  - 0=disable Short
  - x=don't care
  - u=unchanged

- **WRITE\_EN\_OPEN@ON command & READ\_EN\_OPEN@ON command:**

Register Name	Address	Data Code<7:0>								Comments
EN_OPEN@ON	5A	x	x	b5	b4	b3	b2	b1	b0	Enable Open@on CH5 to CH0
EN_OPEN@ON	5B	x	x	b11	b10	b9	b8	b7	b6	Enable Open@on CH11 to CH6
EN_OPEN@ON	9A	u	u	b5	b4	b3	b2	b1	b0	Read Enable Open@on CH5 to CH0
EN_OPEN@ON	9B	u	u	b11	b10	b9	b8	b7	b6	Read Enable Open@on CH11 to CH6

- Code:
  - 1=enable Open
  - 0=disable Open
  - x=don't care
  - u=unchanged

- **WRITE\_EN\_SHORT@OFF command & READ\_EN\_SHORT@OFF command:**

Register Name	Address	Data Code<7:0>								Comments
EN_SHORT@OFF	5C	x	x	b5	b4	b3	b2	b1	b0	Enable Short@off CH5 to CH0
EN_SHORT@OFF	5D	x	x	b11	b10	b9	b8	b7	b6	Enable Short@off CH11 to CH6
EN_SHORT@OFF	9C	u	u	b5	b4	b3	b2	b1	b0	Read Enable Short@off CH5 to CH0
EN_SHORT@OFF	9D	u	u	b11	b10	b9	b8	b7	b6	Read Enable Short@off CH11 to CH6

- Code:
  - 1=enable Short
  - 0=disable Short
  - x=don't care
  - u=unchanged

- **WRITE\_EN\_OPEN@OFF command & READ\_EN\_OPEN@OFF command:**

Register Name	Address	Data Code<7:0>								Comments
EN_OPEN@OFF	5E	x	x	b5	b4	b3	b2	b1	b0	Enable Open@off CH5 to CH0
EN_OPEN@OFF	5F	x	x	b11	b10	b9	b8	b7	b6	Enable Open@off CH11 to CH6
EN_OPEN@OFF	9E	u	u	b5	b4	b3	b2	b1	b0	Read Enable Open@off CH5 to CH0
EN_OPEN@OFF	9F	u	u	b11	b10	b9	b8	b7	b6	Read Enable Open@off CH11 to CH6

- Code:
  - 1=enable Open
  - 0=disable Open
  - x=don't care
  - u=unchanged

- **WRITE\_EN\_SHORT\_TO\_GND command & READ\_EN\_SHORT\_TO\_GND command:**

Register Name	Address	Data Code<7:0>								Comments
EN_SHORT_TO_GND	60	x	x	b5	b4	b3	b2	b1	b0	Enable Short to gnd CH5 to CH0
EN_SHORT_TO_GND	61	x	x	b11	b10	b9	b8	b7	b6	Enable Short to gnd CH11 to CH6
EN_SHORT_TO_GND	A0	u	u	b5	b4	b3	b2	b1	b0	Read Enable Short to gnd CH5 to CH0
EN_SHORT_TO_GND	A1	u	u	b11	b10	b9	b8	b7	b6	Read Enable Short to gnd CH11 to CH6

- Code:
  - 1=enable Short to ground
  - 0=disable Short to ground
  - x=don't care
  - u=unchanged

- **WRITE\_EN\_PULL\_UP@ON command & READ\_EN\_PULL\_UP@ON command:**

Register Name	Address	Data Code<7:0>								Comments
EN_PULL_UP@ON	62	x	x	b5	b4	b3	b2	b1	b0	Enable pull up@on CH5 to CH0
EN_PULL_UP@ON	63	x	x	b11	b10	b9	b8	b7	b6	Enable pull up@on CH11 to CH6
EN_PULL_UP@ON	A2	u	u	b5	b4	b3	b2	b1	b0	Read Enable pull up@on CH5 to CH0
EN_PULL_UP@ON	A3	u	u	b11	b10	b9	b8	b7	b6	Read Enable pull up@on CH11 to CH6

- Code:
  - 1=enable pull up
  - 0=disable pull up
  - x=don't care
  - u=unchanged

- **WRITE\_EN\_PULL\_UP@OFF command & READ\_PULL\_UP@OFF command:**

Register Name	Address	Data Code<7:0>								Comments
EN_PULL_UP@OFF	64	x	x	b5	b4	b3	b2	b1	b0	Enable pull up@off CH5 to CH0
EN_PULL_UP@OFF	65	x	x	b11	b10	b9	b8	b7	b6	Enable pull up@off CH11 to CH6
EN_PULL_UP@OFF	A4	u	u	b5	b4	b3	b2	b1	b0	Read Enable pull up@off CH5 to CH0
EN_PULL_UP@OFF	A5	u	u	b11	b10	b9	b8	b7	b6	Read Enable pull up@off CH11 to CH6

- Code:
  - 1=enable pull up
  - 0=disable pull up
  - x=don't care
  - u=unchanged

- **WRITE\_EN\_ERR\_PIN command & READ\_EN\_ERR\_PIN command:**

Register Name	Address	Data Code<7:0>								Comments
EN_ERR_PIN	66	x	s6	s5	s4	s3	s2	s1	s0	En ERR pin for status bit6 to bit0
EN_ERR_PIN	67	x	x	x	u4	u3	u2	u1	u0	En ERR pin for unlock bit4 to bit0
EN_ERR_PIN	A6	u	s6	s5	s4	s3	s2	s1	s0	Read En ERR pin for status bit6 to bit0
EN_ERR_PIN	A7	u	u	u	u4	u3	u2	u1	u0	Read En ERR pin for unlock bit4 to bit0

- Code:
  - 1=enable
  - 0=disable
  - x= don't care
  - u=unchanged
  - (see also STATUS/UNLOCK Register Flag Description)

- **WRITE\_MASK\_WLS command:**

Register Name	Address	Data Code<7:0>								Comments
MASK_WLS	68	x	x	x	x	x	x	b1	b0	Make the WLS detection visible

- Code:
  - 01=enable detection
  - 10=disable detection
  - 00=don't touch
  - 11=don't touch
  - x=don't care
  - (Note: b1 and b2 are used as code to change the 1bit MASK\_WLS register)

- **READ\_MASK\_WLS command:**

Register Name	Address	Data Code<7:0>								Comments
MASK_WLS	AB	u	u	u	u	u	u	u	b0	Read Make the WLS detection visible

- Code:

1=visible  
 0=not visible  
 u=unchanged

• **WRITE\_LOCK command:**

Register Name	Address	Data Code<7:0>								Comments
UNLOCK	69	x	x	x	EN_ERR	PWM_MAP	EN_CH	CAL	All DIAG	Lock

- Code: default "11111"=unlocked  
 1=lock  
 0=don't touch  
 x=don't care
- EN\_ERR locks EN\_ERR\_PIN register
- CAL locks CALx registers
- EN\_CH locks EN\_CHANNEL register
- PWM MAP locks PWM\_MAPx registers
- All DIAG locks EN\_SHORT@ON, EN\_OPEN@ON, EN\_SHORT@OFF, EN\_OPEN@OFF, EN\_SHORT\_TO\_GND, EN\_PULL\_UP@ON, EN\_PULL\_UP@OFF, EN\_WLS registers

• **WRITE\_UNLOCK command & READ\_UNLOCK command:**

Register Name	Address	Data Code<7:0>								Comments
UNLOCK	6A	x	x	x	EN_ERR	PWM_MAP	EN_CH	CAL	All DIAG	unlock reg.
UNLOCK	A9	u	u	u	EN_ERR	PWM_MAP	EN_CH	CAL	All DIAG	Read Unlock

- Code for write: 1=unlock  
 0=don't touch  
 x=don't care
- Code for read: default "11111"=unlocked  
 1=unlocked  
 0=locked  
 u=unchanged
- EN\_ERR unlocks EN\_ERR\_PIN register
- CAL unlocks CALx registers
- EN\_CH unlocks EN\_CHANNEL register
- PWM MAP unlocks PWM\_MAPx registers
- All DIAG unlocks EN\_SHORT@ON, EN\_OPEN@ON, EN\_SHORT@OFF, EN\_OPEN@OFF, EN\_SHORT\_TO\_GND, EN\_PULL\_UP@ON, EN\_PULL\_UP@OFF, EN\_WLS registers

• **RESET\_STATUS command:**

Register Name	Address	Data Code<7:0>								Comments
RESET_STATUS	6B	x	x	SHORT to GND	ANY SHORT OPEN	WLS	PWM_OK	TSD	POR	Clear status flags

- Code: 1=reset  
 0=don't touch  
 x=don't care  
 (**Note1:** TSD clears bot TSD130 and TSD180 flags)  
 (**Note2:** After clearing the flags with the RESET\_STATUS command the registers will immediately reflect the actual status)

• **SOFTWARE\_POR command:**

Register Name	Address	Data Code<7:0>								Comments
SOFTWARE_POR	6C	1	0	1	0	0	0	0	1	Resets all registers and sets POR flag HIGH

• **Default Register setting:**

Register	Default values after POR	Comments
CALIBRATION<5:0> (of all channels)	<000000>	Set all currents to min value

PWM_MAP<3:0> (of all channels)	<0000> all channels assigned to PWM0	Assign all channels to PWM0
Gen_OPEN <11:0>	<000000000000>	Default: no fault.
Gen_SHORT <11:0>	<000000000000>	Default: no fault.
SHORT_TO_GND <11:0>	<000000000000>	Default: no fault.
PWM_OK <5:0>	<000000>	Default: fault
EN_CHANNEL<11:0>	<000000000000>	All channels off
EN_OPEN@ON<11:0>	<000000000000>	Open @ on de-activated for all channels
EN_SHORT@ON<11:0>	<000000000000>	Short @ on de-activated for all channels
EN_OPEN@OFF<11:0>	<000000000000>	Open @ off de-activated for all channels
EN_SHORT@OFF<11:0>	<000000000000>	Short @ off de-activated for all channels
EN_SHORT_TO_GND <11:0>	<000000000000>	Short to ground detection de-activated
EN_PULL_UP@ON<11:0>	<000000000000>	All pull-ups de-activated
EN_PULL_UP@OFF<11:0>	<000000000000>	All pull-ups de-activated
EN_ERR_PIN <11:0>	<111111111111>	All warnings activated
UNLOCK<4:0>	<11111>	All groups unlocked
MASK_WLS	<0>	Default: Detection is not visible
STATUS<6:0>	<0000001>	Default: POR detected

- **STATUS / UNLOCK Register Flag Description:**

NAME	STATUS	Default	Comment
POR_FLAG	0	<1>	POR flag (1 = POR detected)
TSD130_FLAG	1	<0>	Die temperature >130°C (1 = over temp)
TSD180_FLAG	2	<0>	Die temperature >180°C (1 = over temp)
WLS_FAULT_FLAG	3	<0>	Weak LED Supply (1 = below threshold)
REXT_FAULT_FLAG	4	<0>	Fault on external reference resistor (1 = out of range)
ANY_SHORT_OPEN_FLAG	5	<0>	At least one short/open detected at any output (1 = short/open detected)
ANY_SHORT_TO_GND_FLAG	6	<0>	Short to GND(1=short to ground detected)
NAME	UNLOCK	Default	Comment
DIAG_UNLOCK_FLAG	0	<1>	DIAG UNLOCK (1 = unlocked)
CAL_UNLOCK_FLAG	1	<1>	CALIBRATION UNLOCK (1 =unlocked)
CH_EN_UNLOCK_FLAG	2	<1>	Channel Enable UNLOCK (1 = unlocked)
PWM_MAP_UNLOCK_FLAG	3	<1>	PWM MAP UNLOCK (1 = unlocked)
EN_ERR_PIN_UNLOCK_FLAG	4	<1>	ERR PIN enable UNLOCK (1=unlocked)

{POR\_FLAG} indicates that a POR event has happen (UVLO or Software POR).

{TSD130\_FLAG} indicates the junction temperature is higher than 130°C.

{TSD180\_FLAG} indicates the junction temperature is higher than 180°C.

{WLS\_FAULT\_FLAG} indicates a LED supply voltage less than normal.

{REXT\_FAULT\_FLAG} indicates either an open or short fault event at the IREF pin.

{ANY\_SHORT\_OPEN\_FLAG} indicates that at least one output channel has detected a short/open event and represents the result of a wired-OR function from Gen SHORT detection, Gen OPEN detection registers content.

{ANY\_SHORT\_TO\_GND\_FLAG} indicates that at least one output channel has detected a short to ground event and represents the result of a wired-OR function from SHORT\_TO\_GND detection registers content.

{DIAG\_UNLOCK\_FLAG} indicates that the enabling of the diagnostics has been locked/unlocked.

{CAL\_UNLOCK\_FLAG} indicates that channel calibration settings have been locked/unlocked.

{CH\_EN\_UNLOCK\_FLAG} indicates that channel enabling settings have been locked/unlocked.

{PWM\_MAP\_UNLOCK\_FLAG} indicates that PWM\_MAP settings have been locked/unlocked.

{EN\_ERR\_PIN\_UNLOCK\_FLAG} indicates that the error pin warning settings have been locked/unlocked.

**Note:** All flags in the STATUS register are asynchronous events. After clearing the flags with the RESET\_STATUS command the registers will immediately reflect the actual status.

**Electrical Characteristic(s)**

(Unless otherwise specified, Ta=-40~+105°C V<sub>CC</sub>=3.0~5.5V)

Item	Symbol	Standard Value			Unit	Conditions			
		Min	Typ	Max					
<b>[Output D0~D11] (Pin No: 5 to 10, 19 to 24)</b>									
Output current accuracy, Channel to Channel <sup>*1</sup>	$\Delta I_{DxA}$	-	-	±15	%	Ta = 25°C V <sub>CC</sub> = 3.3V R <sub>EXT</sub> = 60KΩ	Measured across a 820hm load resistor V <sub>SENSE</sub> =5V	Cal 63	
				±14				Cal 42	
				±16				Cal 20	
		-	-	±5		%		Ta = 25°C V <sub>CC</sub> = 3.3V R <sub>EXT</sub> = 20KΩ	Cal 63
				±3.5					Cal 42
				±6					Cal 20
		-	-	±6		%		Ta = 25°C V <sub>CC</sub> = 3.3V R <sub>EXT</sub> = 12KΩ	Cal 63
				±7					Cal 42
				±7					Cal 20
Output current accuracy Average to Nominal <sup>*2</sup>	$\Delta I_{AN}$	-	-	±8	%	Ta = 25°C V <sub>CC</sub> = 3.3V R <sub>EXT</sub> = 60KΩ	Measured across a 820hm load resistor V <sub>SENSE</sub> =5V	Cal 63	
				±8				Cal 42	
				±8				Cal 20	
		-	-	±3		%		Ta = 25°C V <sub>CC</sub> = 3.3V R <sub>EXT</sub> = 20KΩ	Cal 63
				±2.5					Cal 42
				±3.5					Cal 20
		-	-	±4		%		Ta = 25°C V <sub>CC</sub> = 3.3V R <sub>EXT</sub> = 12KΩ	Cal 63
				±4					Cal 42
				±4					Cal 20
Output current accuracy Channel to Nominal <sup>*3</sup>	$\Delta I_{DxN}$	-	-	±16	%	Ta = 25°C V <sub>CC</sub> = 3.3V R <sub>EXT</sub> = 60KΩ	Measured across a 820hm load resistor V <sub>SENSE</sub> =5V	Cal 63	
				±15				Cal 42	
				±17				Cal 20	
		-	-	±5		%		Ta = 25°C V <sub>CC</sub> = 3.3V R <sub>EXT</sub> = 20KΩ	Cal 63
				±4					Cal 42
				±7					Cal 20
		-	-	±7		%		Ta = 25°C V <sub>CC</sub> = 3.3V R <sub>EXT</sub> = 12KΩ	Cal 63
				±8					Cal 42
				±8					Cal 20
Output current temperature shift <sup>*8</sup>	$\Delta I_{Dx(Temp)}$	0	-	3.2	μA/C	V <sub>CC</sub> = 3.3V R <sub>EXT</sub> = 20KΩ		Cal 63	
Output current supply voltage shift	$\Delta I_{Dx(Vcc)}$	0	-	0.5	mA/V	Ta = 25°C V <sub>CC</sub> =3.0-3.6V R <sub>EXT</sub> = 20KΩ		Cal 63	
		0	-	0.5		Ta = 25°C V <sub>CC</sub> =4.5-5.5V R <sub>EXT</sub> = 20KΩ		Cal 63	
Output leakage Current	I <sub>DLeak</sub>	-	-	0.1	uA	V <sub>D</sub> = V <sub>SENSE</sub> = 8V Ta=25°C			
Minimum output voltage level	V <sub>Dmin</sub>	-	-	0.75	V	I <sub>D</sub> drops to 80%I <sub>Dmax</sub> , R <sub>EXT</sub> = 20KΩ	V <sub>CC</sub> =3.3V	Cal 63	
		-	-	0.51			V <sub>CC</sub> =5V		
Rising time of I <sub>D</sub>	ST1	0.3	0.5	1.2	us	From 10% to 90% of I <sub>Dmax</sub> , R <sub>EXT</sub> = 20KΩ		Cal 63	
Falling time of I <sub>D</sub>	ST2	0.2	0.5	1.2	us	From 90% to 10% of I <sub>Dmax</sub> , R <sub>EXT</sub> = 20KΩ		Cal 63	
Ton error <sup>*4</sup>	RT	-1	0	1	us	Measured at 50% of I <sub>Dmax</sub> , R <sub>EXT</sub> = 20KΩ		Cal 63	
Delay time PWM to I <sub>D</sub>	DT	-	0.26	1	us	From PWM0=10% of V <sub>CC</sub> to I <sub>D</sub> =10% of I <sub>D</sub> max (rising edge), R <sub>EXT</sub> = 20KΩ		Cal 63	

\*1  $\Delta I_{DxA}(\%) = \frac{I_D - I_{av}}{I_{av}} * 100$ , where  $I_{av} = \frac{I_0 + \dots + I_{11}}{12}$

\*2  $\Delta I_{AN}(\%) = \frac{I_{av} - I_{set}}{I_{set}} * 100$ , this represents Device to Device accuracy

\*3  $\Delta I_{DxN}(\%) = \frac{I_D - I_{set}}{I_{set}} * 100$

\*4  $\Delta t$  between pulse width of I<sub>D</sub> relative to the pulse width of PWM, this item represents

PWM duty cycle **Linearity**(%) =  $\frac{|RT|}{Duty_{PWM} * \frac{1}{f_{PWM}}} * 100$

<b>[Logic input] (Pin No: 4, 11 to 17, 25)<sup>*9</sup></b>						
High going threshold voltage	$V_{TH}$	$0.35 \times V_{CC}$	-	$0.45 \times V_{CC}$	V	
Low going threshold voltage	$V_{TL}$	$0.25 \times V_{CC}$	-	$0.35 \times V_{CC}$	V	
Hysteresis width	$V_{HYS}$	-	$0.1 \times V_{CC}$	-	V	
Pull up resistance	$R_{pullup}$	100	200	300	k $\Omega$	Only for Pins:4,11,12,16, 17, 25
Serial clock frequency	$f_{CLK}$	-	-	1250	kHz	
<b>[Logic output] (Pin No: 26)</b>						
Output Voltage high	$V_{OH}$	$0.9 \times V_{CC}$	$0.95 \times V_{CC}$	$1 \times V_{CC}$	V	$I_{SDO} = -4mA$
Output voltage Low	$V_{OL}$	0	$0.05 \times V_{CC}$	$0.1 \times V_{CC}$	V	$I_{SDO} = 4mA$
<b>[Open Drain] (Pin No: 3)</b>						
HIGH LEVEL Output Leakage Current	$I_{ODH\_leak}$	-	-	0.2	$\mu A$	$V_{CC} = 3.3V$
LOW LEVEL Output Voltage	$V_{ODL}$	-	-	$0.1 \times V_{CC}$	V	$I_{OD} = 4mA$ $V_{CC} = 3.3V$
<b>[DEVICE]</b>						
Circuit Current	$I_{CC}$	-	4	7.5	mA	Pin 3 = OPEN Pin 26 = OPEN $R_{EXT} = 20K\Omega$
Under voltage lockout	UVLO_L	2.2	2.5	2.8	V	Falling $V_{CC}$
Under voltage release	UVLO_H	2.4	2.7	3.0	V	Rising $V_{CC}$
SHORT detection Threshold	$V_{SCth}$	0.45	-	0.93	V	Measured across LED $V_{SENSE}=5V$
Diag. detection pull down current	$I_{pulldown}$	14	20	30	$\mu A$	Measured at Channel OFF
SHORT_to_GND pull-up current	$I_{pullup}$	14	20	30	$\mu A$	Measured at Channel OFF
Minimum glitch Reject <sup>*5*8</sup>	$t_{glitch\_reject}$	-	-	7.5	us	For OPEN / SHORT detection
ON Time <sup>*6*7</sup>	$t_{ON}$	8	-	-	us	Minimum requirement for OPEN/SHORT detection.
LED Short/Open detection window	$t_{diag\_off}$	12	20	31	us	At Channel OFF and PWMY="HIGH"
OPEN detection threshold	$V_{Oth}$	100	-	330	mV	Measured from Output to AGND, $V_{SENSE}=5V$
SHORT_to_GND detection threshold	$V_{SGth}$	100	-	330	mV	At Channel OFF and PWMY="HIGH", $V_{SENSE}=5V$
Weak LED Supply detection threshold	$V_{WLSth\_L}$	4.0	4.15	4.3	V	Measured at $V_{SENSE}$
IREF short threshold	$I_{short}$	116	-	220	$\mu A$	Measured at IREF pin $V_{CC} = 4.5\sim 5.5V$ $V_{CC} = 3.0\sim 3.6V$ <sup>*8</sup>
		116	-	300	$\mu A$	
IREF open threshold	$I_{open}$	2	-	16	$\mu A$	Measured at IREF pin
IREF Limp Home	$I_{REF\_LH}$	6	10	16	mA	Measured at Output in case of short or open at IREF pin
Reference Voltage	$V_{REF}$	1.17	1.2	1.23	V	$R_{EXT} = 20k\Omega$ connected to IREF pin
Temperature monitoring accuracy <sup>*8</sup>	$T_{MON}$	-15	-	15	%	At 130°C and 180°C
Temperature hysteresis <sup>*8</sup>	$T_{hyst}$	7	10	13	°C	At 130°C and 180°C
SENSE pin input current	$I_{SENSE}$	-	18	-	$\mu A$	$V_{SENSE}=5V$

\*5 An OPEN or SHORT that lasts for less than this time will be rejected.

\*6 Please note that the PWM signal is active LOW therefore, the  $t_{ON}$  time denotes the period when the signal is at LOW level.

\*7 This period is derived from a PWM frequency of 200Hz and a minimum duty cycle of 0.2%.

\*8 Guaranteed by design.

\*9 The input circuitry operates as a Schmitt trigger and the operation is not affected by the rise and fall times of the input signals.

Typical Performance Curve(s)

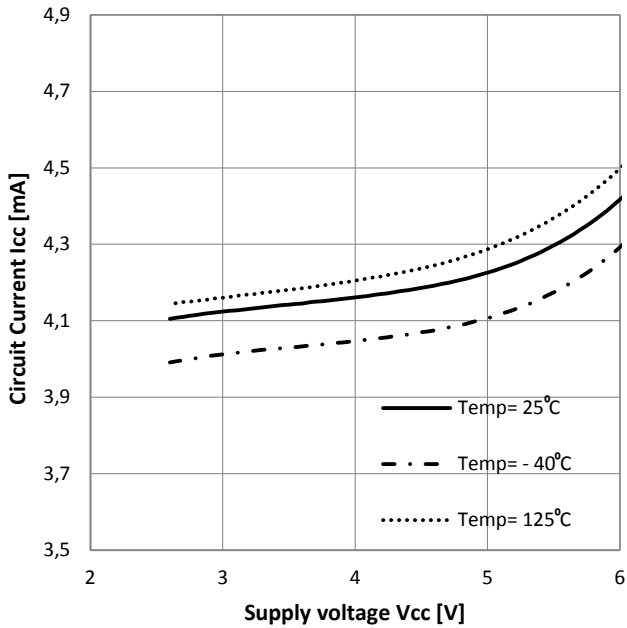

Figure 7. Circuit current vs. supply voltage

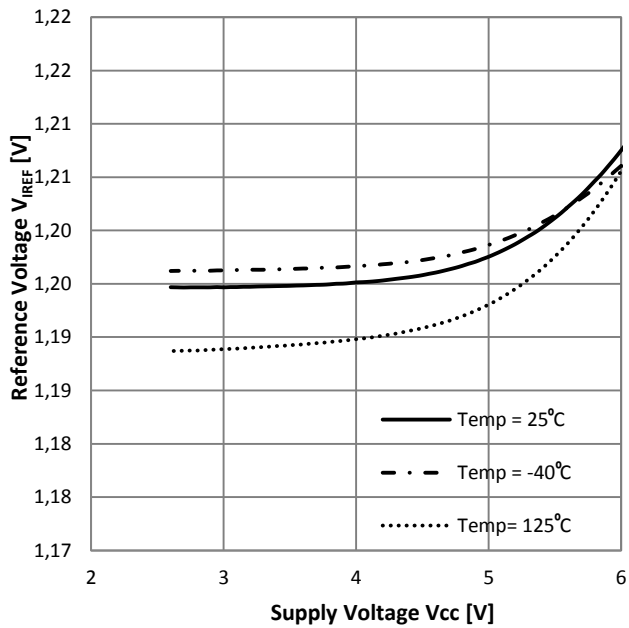

Figure 8. Ref voltage vs. supply voltage

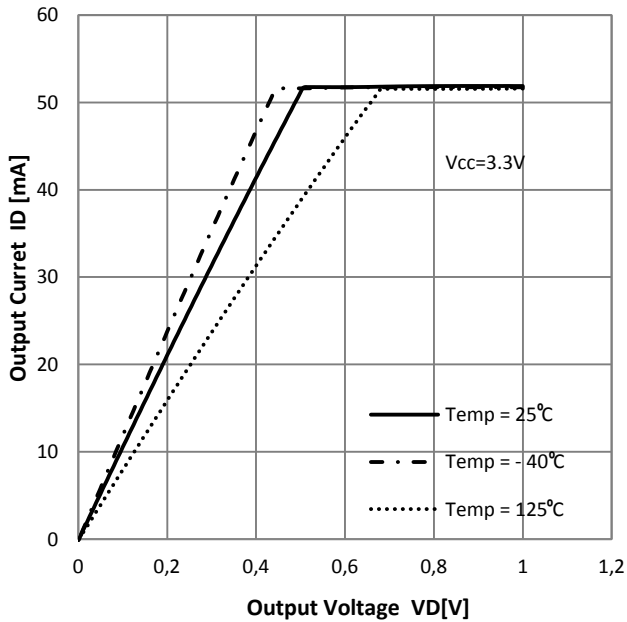

Figure 9. Output current vs. output voltage

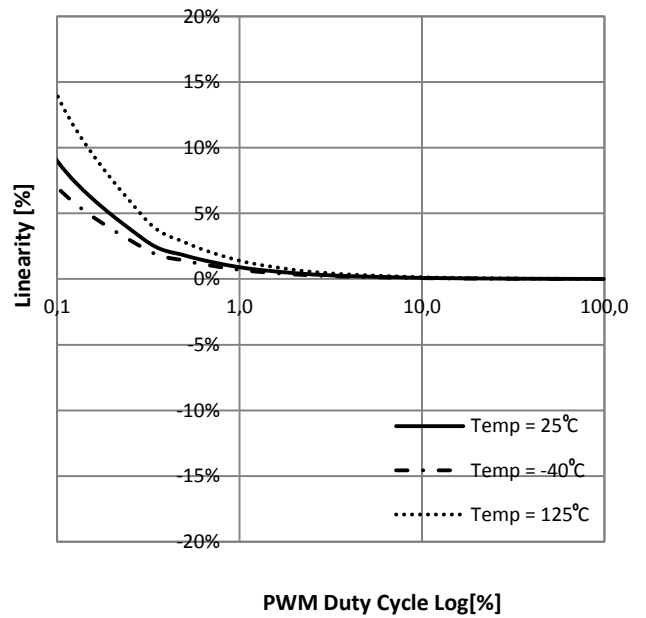

Figure 10. Output current linearity(RT) vs. PWM

SPI Timing Chart

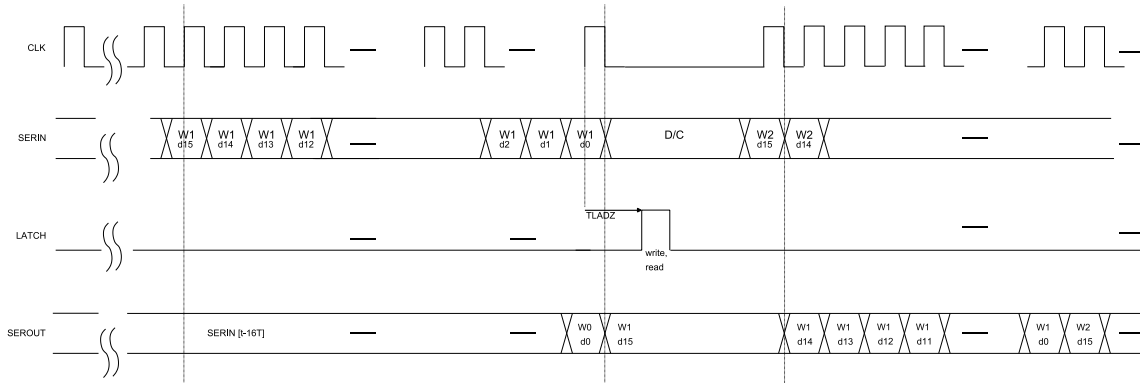

Figure 11. Write/access data for typical use case

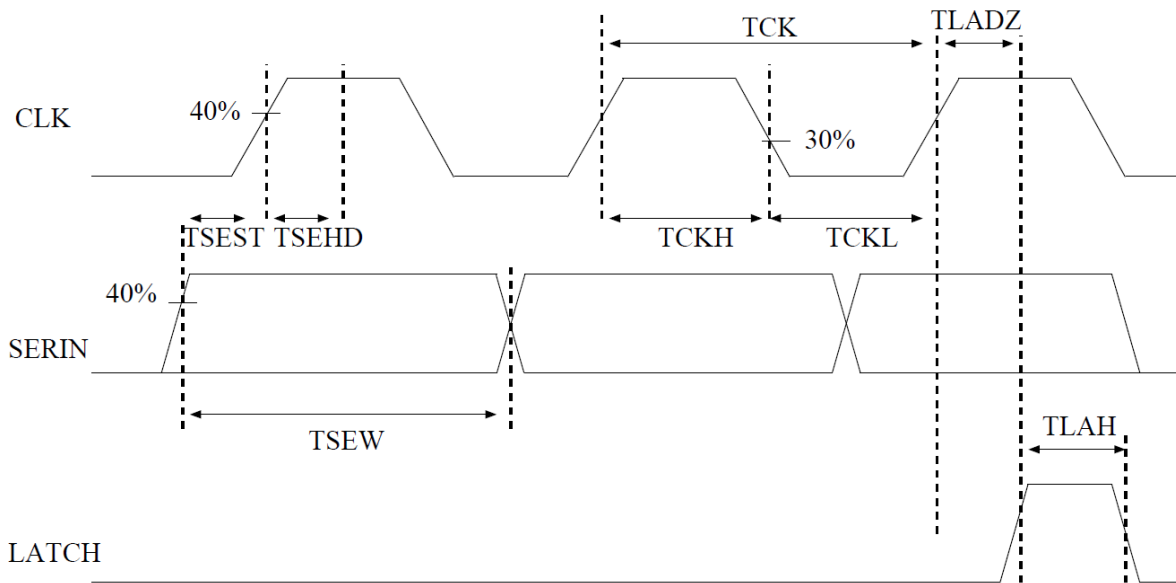

Figure 12. Input signals timing diagram showing absolute minimal timing

INPUT SIGNAL's TIMING RULE (Ta=-40~+105°C VCC=3.0~5.5V)

Parameter	Symbol	Min	Unit
CLK period	TCK	800	ns
CLK high pulse width	TCKH	300	ns
CLK low pulse width	TCKL	300	ns
SERIN high and low pulse width	TSEW	780	ns
SERIN setup time prior to CLK rise	TSEST	150	ns
SERIN hold time after CLK rise	TSEHD	150	ns
LATCH high pulse time	TLAH	380	ns
LAST CLK rise to LATCH rise	TLADZ	200	ns

The timings are valid for a 1.25MHz clock signal. The input High Going threshold voltage ( $V_{TH}$ ) is 0.4  $V_{CC}$  on the rising edge and ( $V_{TH}$ ) 0.3  $V_{CC}$  on the falling edge for all digital pins. See electrical characteristics.



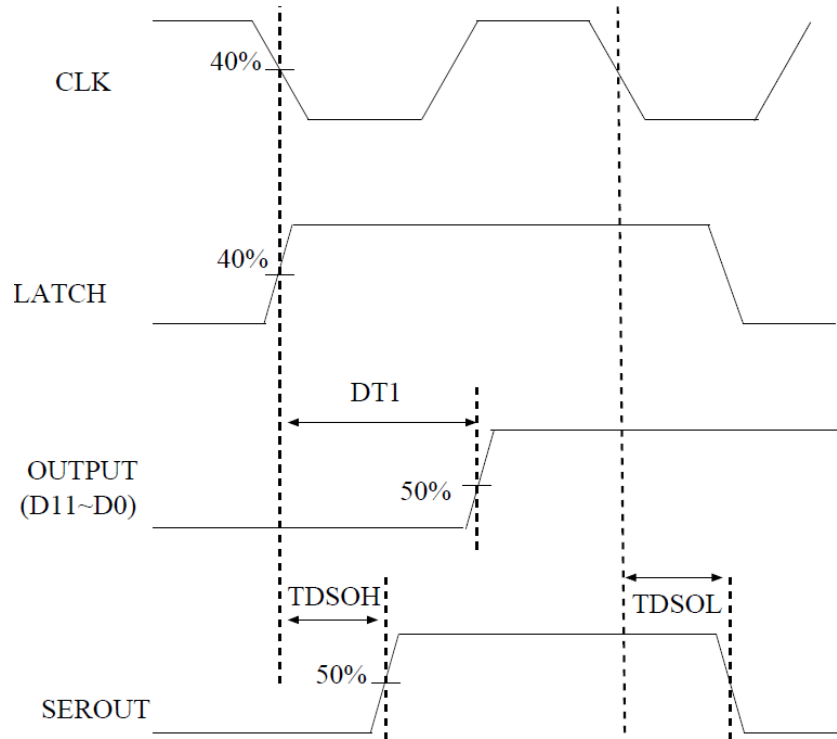

Figure 13. Timing diagram for output signal's delay time

**OUTPUT SIGNAL'S DELAY TIME (Ta=-40~+105°C VCC=3.0~5.5V)**

Parameter	Symbol	Min.	Typ.	Max.	Unit	Condition
LATCH switching delay	DT1	-	-	3000	ns	
SEROUT propagation delay time(L→H)	TDSOH	-	-	1300	ns	
SEROUT propagation delay(H→L)	TDSOL	-	-	1300	ns	

Output signal's delay time

SPI Communication

The serial port is used to write data, read diagnostic status and configure settings of the chip by transferring the input data to the desired address. During normal operation an 8-bit serial address and 8-bit serial data is written into the 16-bit shift register. The clock idle state is zero and the data on the SDI and SDO lines must be stable while the clock is high and can be changed when the clock is low. The data is sampled by on the clock's rising edge and propagated on the clock's falling edge, converting the 16 most recent inputs to parallel signals on the LATCH rising edge.

At the rising edge on the LATCH input addresses are interpreted by a decoder which controls data transfer between shift and storage registers. Depending on the address, valid data is conveyed from or to the appropriate latch or a command is interpreted. When a read address is latched data is read out from a storage register and shifted out of SDO to the microcontroller or daisy chained chips.

Since for each address the chip shifts out a fixed amount of data at the end of a write/read cycle it is possible to send different address codes to each IC in a daisy chain.

During the exchange of information the LED outputs do not flicker or dim.

Command Set

Address N<15>[b]	Data IN <7:0>								Comments	
	d7	d6	d5	d4	d3	d2	d1	d0		
40	PWM_MAP01<3>	PWM_MAP01<2>	PWM_MAP01<1>	PWM_MAP01<0>	PWM_MAP00<3>	PWM_MAP00<2>	PWM_MAP00<1>	PWM_MAP00<0>	Configures Output Ch1&Ch0 to PWM	
41	PWM_MAP03<3>	PWM_MAP03<2>	PWM_MAP03<1>	PWM_MAP03<0>	PWM_MAP02<3>	PWM_MAP02<2>	PWM_MAP02<1>	PWM_MAP02<0>	Configures Output Ch3&Ch2 to PWM	
42	PWM_MAP05<3>	PWM_MAP05<2>	PWM_MAP05<1>	PWM_MAP05<0>	PWM_MAP04<3>	PWM_MAP04<2>	PWM_MAP04<1>	PWM_MAP04<0>	Configures Output Ch5&Ch4 to PWM	
43	PWM_MAP07<3>	PWM_MAP07<2>	PWM_MAP07<1>	PWM_MAP07<0>	PWM_MAP06<3>	PWM_MAP06<2>	PWM_MAP06<1>	PWM_MAP06<0>	Configures Output Ch7&Ch6 to PWM	
44	PWM_MAP09<3>	PWM_MAP09<2>	PWM_MAP09<1>	PWM_MAP09<0>	PWM_MAP08<3>	PWM_MAP08<2>	PWM_MAP08<1>	PWM_MAP08<0>	Configures Output Ch9&Ch8 to PWM	
45	PWM_MAP11<3>	PWM_MAP11<2>	PWM_MAP11<1>	PWM_MAP11<0>	PWM_MAP10<3>	PWM_MAP10<2>	PWM_MAP10<1>	PWM_MAP10<0>	Configures Output Ch11&Ch10 to PWM	
46	Not USED	Not USED	Not USED	Not USED	Not USED	Not USED	Not USED	Not USED	Not USED	
47	Not USED	Not USED	Not USED	Not USED	Not USED	Not USED	Not USED	Not USED	Not USED	
48	X	X	CAL0<5>	CAL0<4>	CAL0<3>	CAL0<2>	CAL0<1>	CAL0<0>	Current configuration Ch0	
49	X	X	CAL1<5>	CAL1<4>	CAL1<3>	CAL1<2>	CAL1<1>	CAL1<0>	Current configuration Ch1	
4A	X	X	CAL2<5>	CAL2<4>	CAL2<3>	CAL2<2>	CAL2<1>	CAL2<0>	Current configuration Ch2	
4B	X	X	CAL3<5>	CAL3<4>	CAL3<3>	CAL3<2>	CAL3<1>	CAL3<0>	Current configuration Ch3	
4C	X	X	CAL4<5>	CAL4<4>	CAL4<3>	CAL4<2>	CAL4<1>	CAL4<0>	Current configuration Ch4	
4D	X	X	CAL5<5>	CAL5<4>	CAL5<3>	CAL5<2>	CAL5<1>	CAL5<0>	Current configuration Ch5	
4E	X	X	CAL6<5>	CAL6<4>	CAL6<3>	CAL6<2>	CAL6<1>	CAL6<0>	Current configuration Ch6	
4F	X	X	CAL7<5>	CAL7<4>	CAL7<3>	CAL7<2>	CAL7<1>	CAL7<0>	Current configuration Ch7	
50	X	X	CAL8<5>	CAL8<4>	CAL8<3>	CAL8<2>	CAL8<1>	CAL8<0>	Current configuration Ch8	
51	X	X	CAL9<5>	CAL9<4>	CAL9<3>	CAL9<2>	CAL9<1>	CAL9<0>	Current configuration Ch9	
52	X	X	CAL10<5>	CAL10<4>	CAL10<3>	CAL10<2>	CAL10<1>	CAL10<0>	Current configuration Ch10	
53	X	X	CAL11<5>	CAL11<4>	CAL11<3>	CAL11<2>	CAL11<1>	CAL11<0>	Current configuration Ch11	
54	Not USED	Not USED	Not USED	Not USED	Not USED	Not USED	Not USED	Not USED	Not USED	
55	Not USED	Not USED	Not USED	Not USED	Not USED	Not USED	Not USED	Not USED	Not USED	
56	X	X	EN_CHANNEL<5>	EN_CHANNEL<4>	EN_CHANNEL<3>	EN_CHANNEL<2>	EN_CHANNEL<1>	EN_CHANNEL<0>	Configure enable channel register for Ch 5 to Ch0	
57	X	X	EN_CHANNEL<11>	EN_CHANNEL<10>	EN_CHANNEL<9>	EN_CHANNEL<8>	EN_CHANNEL<7>	EN_CHANNEL<6>	Configure enable channel register for Ch 11 to Ch6	
58	X	X	EN_SHORT@ON<5>	EN_SHORT@ON<4>	EN_SHORT@ON<3>	EN_SHORT@ON<2>	EN_SHORT@ON<1>	EN_SHORT@ON<0>	Configure enable short for activated Ch5 to Ch0	
59	X	X	EN_SHORT@ON<11>	EN_SHORT@ON<10>	EN_SHORT@ON<9>	EN_SHORT@ON<8>	EN_SHORT@ON<7>	EN_SHORT@ON<6>	Configure enable short for activated Ch11 to Ch6	
5A	X	X	EN_OPEN@ON<5>	EN_OPEN@ON<4>	EN_OPEN@ON<3>	EN_OPEN@ON<2>	EN_OPEN@ON<1>	EN_OPEN@ON<0>	Configure enable open for activated Ch5 to Ch0	
5B	X	X	EN_OPEN@ON<11>	EN_OPEN@ON<10>	EN_OPEN@ON<9>	EN_OPEN@ON<8>	EN_OPEN@ON<7>	EN_OPEN@ON<6>	Configure enable open for activated Ch11 to Ch6	
5C	X	X	EN_SHORT@OFF<5>	EN_SHORT@OFF<4>	EN_SHORT@OFF<3>	EN_SHORT@OFF<2>	EN_SHORT@OFF<1>	EN_SHORT@OFF<0>	Configure enable short for unactivated Ch5 to Ch0	
5D	X	X	EN_SHORT@OFF<11>	EN_SHORT@OFF<10>	EN_SHORT@OFF<9>	EN_SHORT@OFF<8>	EN_SHORT@OFF<7>	EN_SHORT@OFF<6>	Configure enable short for unactivated Ch11 to Ch6	
5E	X	X	EN_OPEN@OFF<5>	EN_OPEN@OFF<4>	EN_OPEN@OFF<3>	EN_OPEN@OFF<2>	EN_OPEN@OFF<1>	EN_OPEN@OFF<0>	Configure enable open for unactivated Ch5 to Ch0	
5F	X	X	EN_OPEN@OFF<11>	EN_OPEN@OFF<10>	EN_OPEN@OFF<9>	EN_OPEN@OFF<8>	EN_OPEN@OFF<7>	EN_OPEN@OFF<6>	Configure enable open for unactivated Ch11 to Ch6	
60	X	X	EN_SHORT_TO_GND<5>	EN_SHORT_TO_GND<4>	EN_SHORT_TO_GND<3>	EN_SHORT_TO_GND<2>	EN_SHORT_TO_GND<1>	EN_SHORT_TO_GND<0>	Enable short to GND for Ch5 to Ch0	
61	X	X	EN_SHORT_TO_GND<11>	EN_SHORT_TO_GND<10>	EN_SHORT_TO_GND<9>	EN_SHORT_TO_GND<8>	EN_SHORT_TO_GND<7>	EN_SHORT_TO_GND<6>	Enable short to GND for Ch11 to Ch6	
62	X	X	EN_PULL_UP@ON<5>	EN_PULL_UP@ON<4>	EN_PULL_UP@ON<3>	EN_PULL_UP@ON<2>	EN_PULL_UP@ON<1>	EN_PULL_UP@ON<0>	Enable pull up @ ON for Ch5 to Ch0	
63	X	X	EN_PULL_UP@ON<11>	EN_PULL_UP@ON<10>	EN_PULL_UP@ON<9>	EN_PULL_UP@ON<8>	EN_PULL_UP@ON<7>	EN_PULL_UP@ON<6>	Enable pull up @ ON for Ch11 to Ch6	
64	X	X	EN_PULL_UP@OFF<5>	EN_PULL_UP@OFF<4>	EN_PULL_UP@OFF<3>	EN_PULL_UP@OFF<2>	EN_PULL_UP@OFF<1>	EN_PULL_UP@OFF<0>	Enable pull up @ OFF for Ch5 to Ch0	
65	X	X	EN_PULL_UP@OFF<11>	EN_PULL_UP@OFF<10>	EN_PULL_UP@OFF<9>	EN_PULL_UP@OFF<8>	EN_PULL_UP@OFF<7>	EN_PULL_UP@OFF<6>	Enable pull up @ OFF for Ch11 to Ch6	
66	X	s<6>	s<5>	s<4>	s<3>	s<2>	s<1>	s<0>	Enable ERR PIN for STATUS bit6 to bit0	
67	X	X	X	u<4>	u<3>	u<2>	u<1>	u<0>	Enable ERR PIN for UNLOCK bit4 to bit0	
68	X	X	X	X	X	X	MASK_WLS<1>	MASK_WLS<0>	Mask WLS detection	
69	X	X	X	EN_ERR_PIN_LOCK<4>	MAP_LOCK<3>	CH_EN_LOCK<2>	CAL_LOCK<1>	DIAG_LOCK<0>	LOCK	
6A	X	X	X	EN_ERR_PIN_UNLOCK<4>	MAP_UNLOCK<3>	CH_EN_UNLOCK<2>	CAL_UNLOCK<1>	DIAG_UNLOCK<0>	UNLOCK	
6B	X	X	X	RST_ANY_SHRT_GND<5>	RST_ANY_SHRT_OPEN<4>	RST_WLS<3>	RST_PWM_OK<2>	RST_TSD<1>	RST_POR<0>	Clear STATUS register flags
6C	1	0	1	0	0	0	0	0	Software reset (reset all and set POR flag)	
6D	Not USED	Not USED	Not USED	Not USED	Not USED	Not USED	Not USED	Not USED	Not USED	
6E	Not USED	Not USED	Not USED	Not USED	Not USED	Not USED	Not USED	Not USED	Not USED	
6F	Not USED	Not USED	Not USED	Not USED	Not USED	Not USED	Not USED	Not USED	Not USED	

X= don't care

Address OUT <15:8>	Data OUT <7:0>								Comments
	d7	d6	d5	d4	d3	d2	d1	d0	
80	PWM_MAP01<3>	PWM_MAP01<2>	PWM_MAP01<1>	PWM_MAP01<0>	PWM_MAP00<3>	PWM_MAP00<2>	PWM_MAP00<1>	PWM_MAP00<0>	Read output Ch1&Ch0 to PWM configuration
81	PWM_MAP03<3>	PWM_MAP03<2>	PWM_MAP03<1>	PWM_MAP03<0>	PWM_MAP02<3>	PWM_MAP02<2>	PWM_MAP02<1>	PWM_MAP02<0>	Read output Ch3&Ch2 to PWM configuration
82	PWM_MAP05<3>	PWM_MAP05<2>	PWM_MAP05<1>	PWM_MAP05<0>	PWM_MAP04<3>	PWM_MAP04<2>	PWM_MAP04<1>	PWM_MAP04<0>	Read output Ch5&Ch4 to PWM configuration
83	PWM_MAP07<3>	PWM_MAP07<2>	PWM_MAP07<1>	PWM_MAP07<0>	PWM_MAP06<3>	PWM_MAP06<2>	PWM_MAP06<1>	PWM_MAP06<0>	Read output Ch7&Ch6 to PWM configuration
84	PWM_MAP09<3>	PWM_MAP09<2>	PWM_MAP09<1>	PWM_MAP09<0>	PWM_MAP08<3>	PWM_MAP08<2>	PWM_MAP08<1>	PWM_MAP08<0>	Read output Ch9&Ch8 to PWM configuration
85	PWM_MAP11<3>	PWM_MAP11<2>	PWM_MAP11<1>	PWM_MAP11<0>	PWM_MAP10<3>	PWM_MAP10<2>	PWM_MAP10<1>	PWM_MAP10<0>	Read output Ch11&Ch10 to PWM configuration
86	Not USED	Not USED	Not USED	Not USED	Not USED	Not USED	Not USED	Not USED	Not USED
87	Not USED	Not USED	Not USED	Not USED	Not USED	Not USED	Not USED	Not USED	Not USED
88	U	U	CAL0<5>	CAL0<4>	CAL0<3>	CAL0<2>	CAL0<1>	CAL0<0>	Read output configuration Ch0
89	U	U	CAL1<5>	CAL1<4>	CAL1<3>	CAL1<2>	CAL1<1>	CAL1<0>	Read output configuration Ch1
8A	U	U	CAL2<5>	CAL2<4>	CAL2<3>	CAL2<2>	CAL2<1>	CAL2<0>	Read output configuration Ch2
8B	U	U	CAL3<5>	CAL3<4>	CAL3<3>	CAL3<2>	CAL3<1>	CAL3<0>	Read output configuration Ch3
8C	U	U	CAL4<5>	CAL4<4>	CAL4<3>	CAL4<2>	CAL4<1>	CAL4<0>	Read output configuration Ch4
8D	U	U	CAL5<5>	CAL5<4>	CAL5<3>	CAL5<2>	CAL5<1>	CAL5<0>	Read output configuration Ch5
8E	U	U	CAL6<5>	CAL6<4>	CAL6<3>	CAL6<2>	CAL6<1>	CAL6<0>	Read output configuration Ch6
8F	U	U	CAL7<5>	CAL7<4>	CAL7<3>	CAL7<2>	CAL7<1>	CAL7<0>	Read output configuration Ch7
90	U	U	CAL8<5>	CAL8<4>	CAL8<3>	CAL8<2>	CAL8<1>	CAL8<0>	Read output configuration Ch8
91	U	U	CAL9<5>	CAL9<4>	CAL9<3>	CAL9<2>	CAL9<1>	CAL9<0>	Read output configuration Ch9
92	U	U	CAL10<5>	CAL10<4>	CAL10<3>	CAL10<2>	CAL10<1>	CAL10<0>	Read output configuration Ch10
93	U	U	CAL11<5>	CAL11<4>	CAL11<3>	CAL11<2>	CAL11<1>	CAL11<0>	Read output configuration Ch11
94	Not USED	Not USED	Not USED	Not USED	Not USED	Not USED	Not USED	Not USED	Not USED
95	Not USED	Not USED	Not USED	Not USED	Not USED	Not USED	Not USED	Not USED	Not USED
96	U	U	EN_CHANNEL<5>	EN_CHANNEL<4>	EN_CHANNEL<3>	EN_CHANNEL<2>	EN_CHANNEL<1>	EN_CHANNEL<0>	Read enable channel register for Ch 5 to Ch0
97	U	U	EN_CHANNEL<11>	EN_CHANNEL<10>	EN_CHANNEL<9>	EN_CHANNEL<8>	EN_CHANNEL<7>	EN_CHANNEL<6>	Read enable channel register for Ch 11 to Ch6
98	U	U	EN_SHORT@ON<5>	EN_SHORT@ON<4>	EN_SHORT@ON<3>	EN_SHORT@ON<2>	EN_SHORT@ON<1>	EN_SHORT@ON<0>	Read enable short for activated Ch5 to Ch0
99	U	U	EN_SHORT@ON<11>	EN_SHORT@ON<10>	EN_SHORT@ON<9>	EN_SHORT@ON<8>	EN_SHORT@ON<7>	EN_SHORT@ON<6>	Read enable short for activated Ch11 to Ch6
9A	U	U	EN_OPEN@ON<5>	EN_OPEN@ON<4>	EN_OPEN@ON<3>	EN_OPEN@ON<2>	EN_OPEN@ON<1>	EN_OPEN@ON<0>	Read enable open for activated Ch5 to Ch0
9B	U	U	EN_OPEN@ON<11>	EN_OPEN@ON<10>	EN_OPEN@ON<9>	EN_OPEN@ON<8>	EN_OPEN@ON<7>	EN_OPEN@ON<6>	Read enable open for activated Ch11 to Ch6
9C	U	U	EN_SHORT@OFF<5>	EN_SHORT@OFF<4>	EN_SHORT@OFF<3>	EN_SHORT@OFF<2>	EN_SHORT@OFF<1>	EN_SHORT@OFF<0>	Read enable short for unactivated Ch5 to Ch0
9D	U	U	EN_SHORT@OFF<11>	EN_SHORT@OFF<10>	EN_SHORT@OFF<9>	EN_SHORT@OFF<8>	EN_SHORT@OFF<7>	EN_SHORT@OFF<6>	Read enable short for unactivated Ch11 to Ch6
9E	U	U	EN_OPEN@OFF<5>	EN_OPEN@OFF<4>	EN_OPEN@OFF<3>	EN_OPEN@OFF<2>	EN_OPEN@OFF<1>	EN_OPEN@OFF<0>	Read enable open for unactivated Ch5 to Ch0
9F	U	U	EN_OPEN@OFF<11>	EN_OPEN@OFF<10>	EN_OPEN@OFF<9>	EN_OPEN@OFF<8>	EN_OPEN@OFF<7>	EN_OPEN@OFF<6>	Read enable open for unactivated Ch11 to Ch6
A0	U	U	EN_SHORT_TO_GND<5>	EN_SHORT_TO_GND<4>	EN_SHORT_TO_GND<3>	EN_SHORT_TO_GND<2>	EN_SHORT_TO_GND<1>	EN_SHORT_TO_GND<0>	Read enable short to GND for Ch5 to Ch0
A1	U	U	EN_SHORT_TO_GND<11>	EN_SHORT_TO_GND<10>	EN_SHORT_TO_GND<9>	EN_SHORT_TO_GND<8>	EN_SHORT_TO_GND<7>	EN_SHORT_TO_GND<6>	Read enable short to GND for Ch11 to Ch6
A2	U	U	EN_PULL_UP@ON<5>	EN_PULL_UP@ON<4>	EN_PULL_UP@ON<3>	EN_PULL_UP@ON<2>	EN_PULL_UP@ON<1>	EN_PULL_UP@ON<0>	Read enable pull up @ ON for Ch5 to Ch0
A3	U	U	EN_PULL_UP@ON<11>	EN_PULL_UP@ON<10>	EN_PULL_UP@ON<9>	EN_PULL_UP@ON<8>	EN_PULL_UP@ON<7>	EN_PULL_UP@ON<6>	Read enable pull up @ ON for Ch11 to Ch6
A4	U	U	EN_PULL_UP@OFF<5>	EN_PULL_UP@OFF<4>	EN_PULL_UP@OFF<3>	EN_PULL_UP@OFF<2>	EN_PULL_UP@OFF<1>	EN_PULL_UP@OFF<0>	Read enable pull up @ OFF for Ch5 to Ch0
A5	U	U	EN_PULL_UP@OFF<11>	EN_PULL_UP@OFF<10>	EN_PULL_UP@OFF<9>	EN_PULL_UP@OFF<8>	EN_PULL_UP@OFF<7>	EN_PULL_UP@OFF<6>	Read enable pull up @ OFF for Ch11 to Ch6
A6	U	s<6>	s<5>	s<4>	s<3>	s<2>	s<1>	s<0>	read ERR PIN for STATUS bit6 to bit0
A7	U	U	U	u<4>	u<3>	u<2>	u<1>	u<0>	read ERR PIN for UNLOCK bit4 to bit0
A8	U	AnyShortGND<6>	AnyShortOpen<5>	REXT<4>	WLS<3>	TS180<2>	TS130<1>	POR<0>	Read STATUS register bits 6to 0
A9	U	U	U	EN_ERR_PIN_UNLOCK<4>	MAP_UNLOCK<3>	CH_EN_UNLOCK<2>	CAL_UNLOCK<1>	DIAG_UNLOCK<0>	Read UNLOCKED
AA	U	U	PWM_OK<5>	PWM_OK<4>	PWM_OK<3>	PWM_OK<2>	PWM_OK<1>	PWM_OK<0>	Read PWM OK register for PWM5 to PWM0
AB	U	U	U	U	U	U	U	MASK_WLS<0>	Read Mask WLS Detection
AC	U	U	Gen_SHORT<5>	Gen_SHORT<4>	Gen_SHORT<3>	Gen_SHORT<2>	Gen_SHORT<1>	Gen_SHORT<0>	Read short register for Ch5 to Ch0
AD	U	U	Gen_SHORT<11>	Gen_SHORT<10>	Gen_SHORT<9>	Gen_SHORT<8>	Gen_SHORT<7>	Gen_SHORT<6>	Read short register for Ch11 to Ch6
AE	U	U	Gen_OPEN<5>	Gen_OPEN<4>	Gen_OPEN<3>	Gen_OPEN<2>	Gen_OPEN<1>	Gen_OPEN<0>	Read open register for Ch5 to Ch0
AF	U	U	Gen_OPEN<11>	Gen_OPEN<10>	Gen_OPEN<9>	Gen_OPEN<8>	Gen_OPEN<7>	Gen_OPEN<6>	Read open register for Ch11 to Ch6
B0	U	U	SHORT_TO_GND<5>	SHORT_TO_GND<4>	SHORT_TO_GND<3>	SHORT_TO_GND<2>	SHORT_TO_GND<1>	SHORT_TO_GND<0>	Read Short to GND register for Ch5 to Ch0
B1	U	U	SHORT_TO_GND<11>	SHORT_TO_GND<10>	SHORT_TO_GND<9>	SHORT_TO_GND<8>	SHORT_TO_GND<7>	SHORT_TO_GND<6>	Read Short to GND register for Ch11 to Ch6
B2	Not USED	Not USED	Not USED	Not USED	Not USED	Not USED	Not USED	Not USED	Not USED
B3	Not USED	Not USED	Not USED	Not USED	Not USED	Not USED	Not USED	Not USED	Not USED
B4	Not USED	Not USED	Not USED	Not USED	Not USED	Not USED	Not USED	Not USED	Not USED

U=unchanged

**Note:** The IC has also reserved addresses for internal test modes not shown in the above register map. All test modes are digital and are protected by security codes.

**Power Dissipation**

The maximum current specification per output  $I_{D,max} = 50\text{mA}$ . However when all channels are sinking this maximum the total power dissipation exceeds the value set by the package limit. The power dissipation can be estimated using Equation 1. Maximum power dissipation. In case of high current and high voltage it is possible to exceed the maximum power dissipation even at a single channel. Because these situations do not occur often the current limit per channel is set higher such that the flexibility of the system is improved.

It is recommended to connect the LEDs to a 5V supply voltage ( $V_{LED}$ ) for an optimal thermal performance. If the LEDs are connected to a higher voltage care should be taken because power dissipation will increase. LED series resistors ( $R_D$ ) may be added to reduce the voltage drop over the IC output. These resistors are an optional safeguard against exceeding the dissipation limit of BD18378EFV-M. The maximum power rating of the BD18378EFV-M can be read from the figure below.

$$P_{diss,max} > \sum_{i=0}^{11} (V_{LED} - V_{f,i} - I_{D,i} \cdot R_{D,i}) \cdot I_{D,i} \cdot \frac{T_{ON}}{T_{PWM}}$$

$$= \sum_{i=0}^{11} (V_{D,i} \cdot I_{D,i}) \cdot \frac{T_{ON}}{T_{PWM}}$$

Equation 1. Maximum power dissipation

$P_{diss,max}$ : Maximum power dissipation of the package

$V_{LED}$ : Supply voltage of LEDs.

$V_f$ : LED forward voltage

$R_D$ : Optional series resistance.

$T_{PWM}$ : Period of PWM

$T_{ON}$ : ON time (duty) of PWM

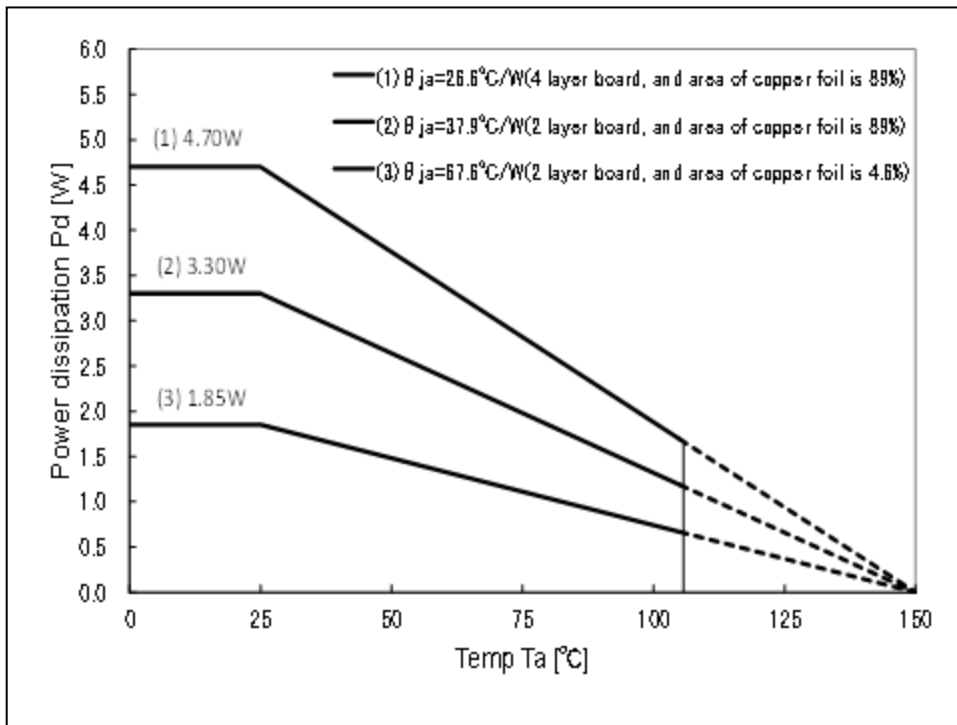

Figure 14. Maximum power dissipation of HTSSOPB28

**Note 1:** Power dissipation calculated when mounted on 70mm X 70mm X 1.6mm glass epoxy substrate (1-layer platform/copper thickness 18µm)

**Note 2:** Power dissipation changes with the copper foil density of the board. This value represents only observed values, not guaranteed values.

**HTSSOP-B28**

$P_d=1.85\text{W}$  (0.97W): Board copper foil area 225m<sup>2</sup>

$P_d=3.30\text{W}$  (1.72W): Board copper foil area 4900m<sup>2</sup>

$P_d=4.70\text{W}$  (2.44W): Board copper foil area 4900m<sup>2</sup>

(Value within parentheses represents power dissipation when  $T_a=85^\circ\text{C}$ )

I/O equivalence circuit(s)

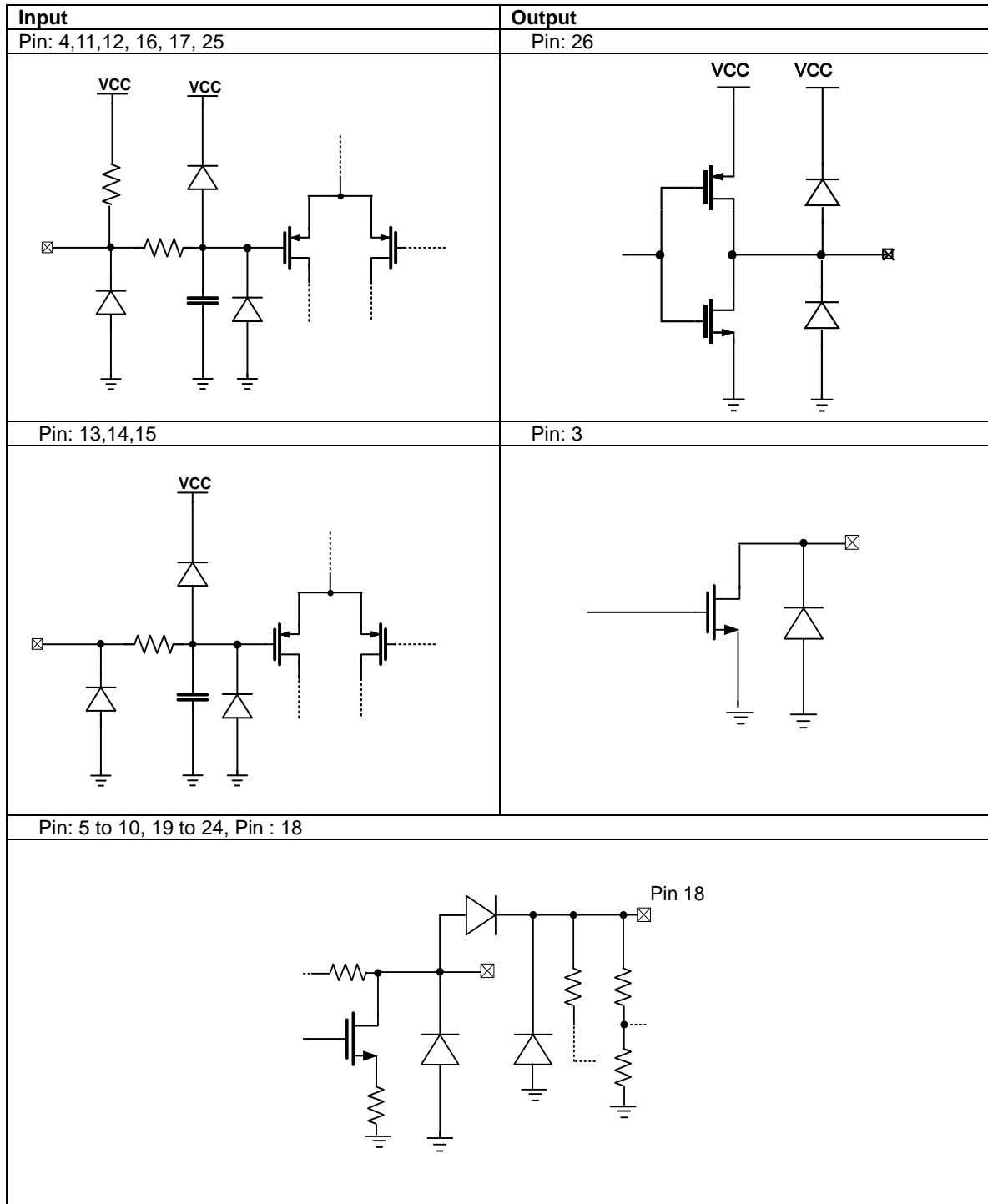

Figure 15. Input/output equivalent circuits

**Operational Notes**

1. **Reverse Connection of Power Supply**  
Connecting the power supply in reverse polarity can damage the IC. Take precautions against reverse polarity when connecting the power supply, such as mounting an external diode between the power supply and the IC's power supply pins.
2. **Power Supply Lines**  
Design the PCB layout pattern to provide low impedance supply lines. Separate the ground and supply lines of the digital and analog blocks to prevent noise in the ground and supply lines of the digital block from affecting the analog block. Furthermore, connect a capacitor to ground at all power supply pins. Consider the effect of temperature and aging on the capacitance value when using electrolytic capacitors.
3. **Ground Voltage**  
Ensure that no pins are at a voltage below that of the ground pin at any time, even during transient condition.
4. **Ground Wiring Pattern**  
When using both small-signal and large-current ground traces, the two ground traces should be routed separately but connected to a single ground at the reference point of the application board to avoid fluctuations in the small-signal ground caused by large currents. Also ensure that the ground traces of external components do not cause variations on the ground voltage. The ground lines must be as short and thick as possible to reduce line impedance.
5. **Thermal Consideration**  
Should by any chance the power dissipation rating be exceeded the rise in temperature of the chip may result in deterioration of the properties of the chip. The absolute maximum rating of the Pd stated in this specification is when the IC is mounted on a 70mm x 70mm x 1.6mm glass epoxy board. In case of exceeding this absolute maximum rating, increase the board size and copper area to prevent exceeding the Pd rating.
6. **Recommended Operating Conditions**  
These conditions represent a range within which the expected characteristics of the IC can be approximately obtained. The electrical characteristics are guaranteed under the conditions of each parameter.
7. **Inrush Current**  
When power is first supplied to the IC, it is possible that the internal logic may be unstable and inrush current may flow instantaneously due to the internal powering sequence and delays, especially if the IC has more than one power supply. Therefore, give special consideration to power coupling capacitance, power wiring, width of ground wiring, and routing of connections.
8. **Operation Under Strong Electromagnetic Field**  
Operating the IC in the presence of a strong electromagnetic field may cause the IC to malfunction.
9. **Testing on Application Boards**  
When testing the IC on an application board, connecting a capacitor directly to a low-impedance output pin may subject the IC to stress. Always discharge capacitors completely after each process or step. The IC's power supply should always be turned off completely before connecting or removing it from the test setup during the inspection process. To prevent damage from static discharge, ground the IC during assembly and use similar precautions during transport and storage.
10. **Inter-pin Short and Mounting Errors**  
Ensure that the direction and position are correct when mounting the IC on the PCB. Incorrect mounting may result in damaging the IC. Avoid nearby pins being shorted to each other especially to ground, power supply and output pin. Inter-pin shorts could be due to many reasons such as metal particles, water droplets (in very humid environment) and unintentional solder bridge deposited in between pins during assembly to name a few.

## Operational Notes – continued

**11. Unused Input Pins**

Input pins of an IC are often connected to the gate of a MOS transistor. The gate has extremely high impedance and extremely low capacitance. If left unconnected, the electric field from the outside can easily charge it. The small charge acquired in this way is enough to produce a significant effect on the conduction through the transistor and cause unexpected operation of the IC. So unless otherwise specified, unused input pins should be connected to the power supply or ground line.

**12. Regarding the Input Pin of the IC**

This monolithic IC contains P+ isolation and P substrate layers between adjacent elements in order to keep them isolated. P-N junctions are formed at the intersection of the P layers with the N layers of other elements, creating a parasitic diode or transistor. For example (refer to figure below):

When  $GND > Pin A$  and  $GND > Pin B$ , the P-N junction operates as a parasitic diode.

When  $GND > Pin B$ , the P-N junction operates as a parasitic transistor.

Parasitic diodes inevitably occur in the structure of the IC. The operation of parasitic diodes can result in mutual interference among circuits, operational faults, or physical damage. Therefore, conditions that cause these diodes to operate, such as applying a voltage lower than the GND voltage to an input pin (and thus to the P substrate) should be avoided.

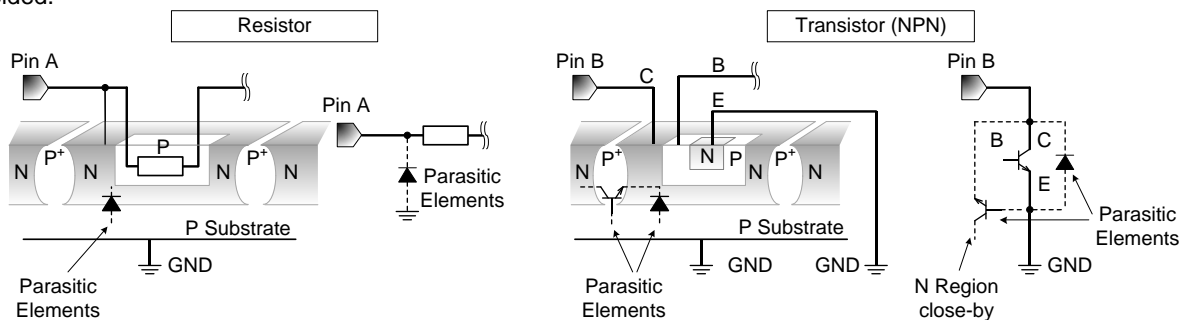

Figure 16. Example of monolithic IC structure

**13. Ceramic Capacitor**

When using a ceramic capacitor, determine the dielectric constant considering the change of capacitance with temperature and the decrease in nominal capacitance due to DC bias and others.

**14. Area of Safe Operation (ASO)**

Operate the IC such that the output voltage, output current, and power dissipation are all within the Area of Safe Operation (ASO).

**15. Thermal Shutdown Circuit(TSD)**

This IC has a built-in thermal shutdown circuit that prevents heat damage to the IC. Normal operation should always be within the IC's power dissipation rating. If however the rating is exceeded for a continued period, the junction temperature ( $T_j$ ) will rise which will activate the TSD circuit that will turn OFF all output pins. When the  $T_j$  falls below the TSD threshold, the circuits are automatically restored to normal operation.

Note that the TSD circuit operates in a situation that exceeds the absolute maximum ratings and therefore, under no circumstances, should the TSD circuit be used in a set design or for any purpose other than protecting the IC from heat damage.

**16. Over Current Protection Circuit (OCP)**

This IC incorporates an integrated overcurrent protection circuit that is activated when the load is shorted. This protection circuit is effective in preventing damage due to sudden and unexpected incidents. However, the IC should not be used in applications characterized by continuous operation or transitioning of the protection circuit.

Ordering Information

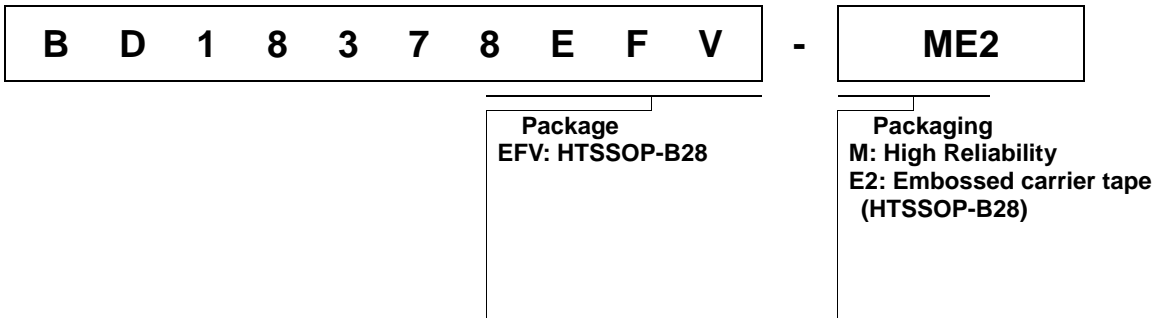

Figure 17. Ordering Information

Marking Diagram

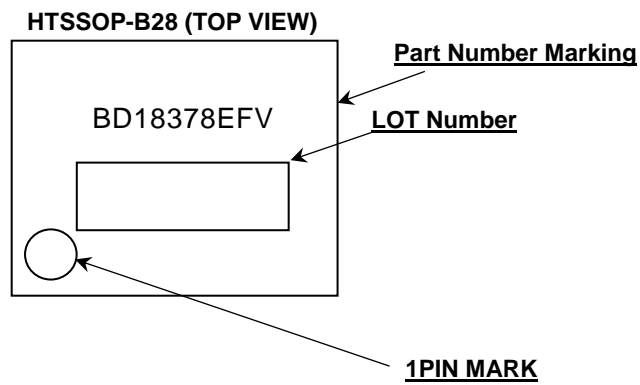

Figure 18. Marking Diagram



Physical Dimensions, Tape And Reel Information for HTSSOP-B28

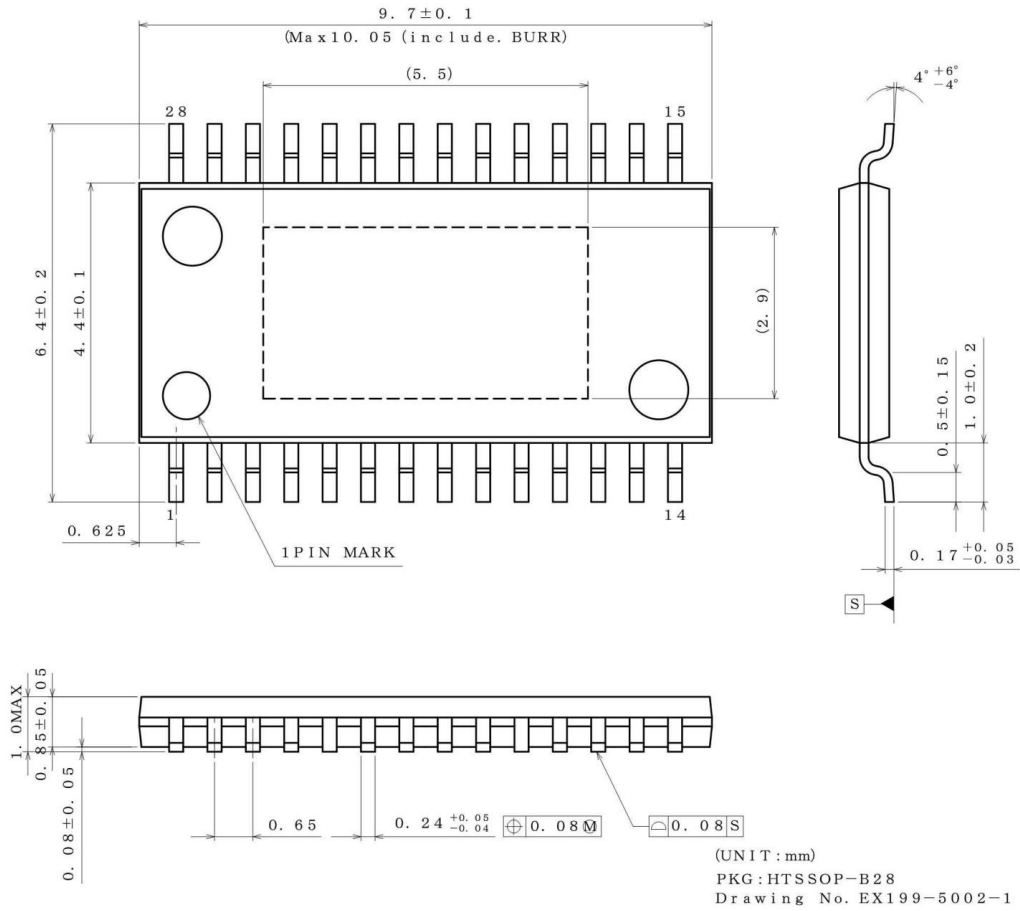

Figure 19. Physical dimensions for HTSSOP-B28

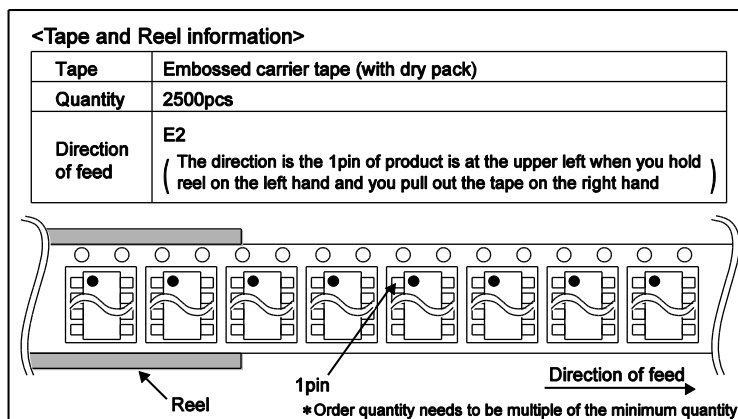

Figure 20. Tape and reel information

## Revision History

Date	Revision	Author / Comments
01.Dec.2014	003	Adrian Joita – Datasheet Release after AEC-Q100 Qualification
04.Dec.2015	004	Adrian Joita -added note for AEC-Q100-Operating Temperature Grade <page 1> -added note for $V_{SENSE}$ <page 3> -added Thermal Information <page 3> -added description of WRITE_CALx & READ_CALx commands <page 8> -added $I_{SENSE}$ parameter <page 14> -added note on input circuitry <page 14> -corrected typo for propagation delay <page17> -added Pin 18 to I/O equivalent circuits <page 21>

## Status of this document

The English version of this document is formal specification. A customer may use the translation version only for a reference to help reading the formal version.

If there are any differences in translation version of this document formal version takes priority.

# Notice

## Precaution on using ROHM Products

- If you intend to use our Products in devices requiring extremely high reliability (such as medical equipment <sup>(Note 1)</sup>, aircraft/spacecraft, nuclear power controllers, etc.) and whose malfunction or failure may cause loss of human life, bodily injury or serious damage to property ("Specific Applications"), please consult with the ROHM sales representative in advance. Unless otherwise agreed in writing by ROHM in advance, ROHM shall not be in any way responsible or liable for any damages, expenses or losses incurred by you or third parties arising from the use of any ROHM's Products for Specific Applications.

(Note1) Medical Equipment Classification of the Specific Applications

JAPAN	USA	EU	CHINA
CLASS III	CLASS III	CLASS II b	CLASS III
CLASS IV		CLASS III	

- ROHM designs and manufactures its Products subject to strict quality control system. However, semiconductor products can fail or malfunction at a certain rate. Please be sure to implement, at your own responsibilities, adequate safety measures including but not limited to fail-safe design against the physical injury, damage to any property, which a failure or malfunction of our Products may cause. The following are examples of safety measures:
  - Installation of protection circuits or other protective devices to improve system safety
  - Installation of redundant circuits to reduce the impact of single or multiple circuit failure
- Our Products are not designed under any special or extraordinary environments or conditions, as exemplified below. Accordingly, ROHM shall not be in any way responsible or liable for any damages, expenses or losses arising from the use of any ROHM's Products under any special or extraordinary environments or conditions. If you intend to use our Products under any special or extraordinary environments or conditions (as exemplified below), your independent verification and confirmation of product performance, reliability, etc. prior to use, must be necessary:
  - Use of our Products in any types of liquid, including water, oils, chemicals, and organic solvents
  - Use of our Products outdoors or in places where the Products are exposed to direct sunlight or dust
  - Use of our Products in places where the Products are exposed to sea wind or corrosive gases, including Cl<sub>2</sub>, H<sub>2</sub>S, NH<sub>3</sub>, SO<sub>2</sub>, and NO<sub>2</sub>
  - Use of our Products in places where the Products are exposed to static electricity or electromagnetic waves
  - Use of our Products in proximity to heat-producing components, plastic cords, or other flammable items
  - Sealing or coating our Products with resin or other coating materials
  - Use of our Products without cleaning residue of flux (even if you use no-clean type fluxes, cleaning residue of flux is recommended); or Washing our Products by using water or water-soluble cleaning agents for cleaning residue after soldering
  - Use of the Products in places subject to dew condensation
- The Products are not subject to radiation-proof design.
- Please verify and confirm characteristics of the final or mounted products in using the Products.
- In particular, if a transient load (a large amount of load applied in a short period of time, such as pulse. is applied, confirmation of performance characteristics after on-board mounting is strongly recommended. Avoid applying power exceeding normal rated power; exceeding the power rating under steady-state loading condition may negatively affect product performance and reliability.
- De-rate Power Dissipation depending on ambient temperature. When used in sealed area, confirm that it is the use in the range that does not exceed the maximum junction temperature.
- Confirm that operation temperature is within the specified range described in the product specification.
- ROHM shall not be in any way responsible or liable for failure induced under deviant condition from what is defined in this document.

## Precaution for Mounting / Circuit board design

- When a highly active halogenous (chlorine, bromine, etc.) flux is used, the residue of flux may negatively affect product performance and reliability.
- In principle, the reflow soldering method must be used on a surface-mount products, the flow soldering method must be used on a through hole mount products. If the flow soldering method is preferred on a surface-mount products, please consult with the ROHM representative in advance.

For details, please refer to ROHM Mounting specification

### Precautions Regarding Application Examples and External Circuits

1. If change is made to the constant of an external circuit, please allow a sufficient margin considering variations of the characteristics of the Products and external components, including transient characteristics, as well as static characteristics.
2. You agree that application notes, reference designs, and associated data and information contained in this document are presented only as guidance for Products use. Therefore, in case you use such information, you are solely responsible for it and you must exercise your own independent verification and judgment in the use of such information contained in this document. ROHM shall not be in any way responsible or liable for any damages, expenses or losses incurred by you or third parties arising from the use of such information.

### Precaution for Electrostatic

This Product is electrostatic sensitive product, which may be damaged due to electrostatic discharge. Please take proper caution in your manufacturing process and storage so that voltage exceeding the Products maximum rating will not be applied to Products. Please take special care under dry condition (e.g. Grounding of human body / equipment / solder iron, isolation from charged objects, setting of ionizer, friction prevention and temperature / humidity control).

### Precaution for Storage / Transportation

1. Product performance and soldered connections may deteriorate if the Products are stored in the places where:
  - [a] the Products are exposed to sea winds or corrosive gases, including Cl<sub>2</sub>, H<sub>2</sub>S, NH<sub>3</sub>, SO<sub>2</sub>, and NO<sub>2</sub>
  - [b] the temperature or humidity exceeds those recommended by ROHM
  - [c] the Products are exposed to direct sunshine or condensation
  - [d] the Products are exposed to high Electrostatic
2. Even under ROHM recommended storage condition, solderability of products out of recommended storage time period may be degraded. It is strongly recommended to confirm solderability before using Products of which storage time is exceeding the recommended storage time period.
3. Store / transport cartons in the correct direction, which is indicated on a carton with a symbol. Otherwise bent leads may occur due to excessive stress applied when dropping of a carton.
4. Use Products within the specified time after opening a humidity barrier bag. Baking is required before using Products of which storage time is exceeding the recommended storage time period.

### Precaution for Product Label

QR code printed on ROHM Products label is for ROHM's internal use only.

### Precaution for Disposition

When disposing Products please dispose them properly using an authorized industry waste company.

### Precaution for Foreign Exchange and Foreign Trade act

Since concerned goods might be fallen under listed items of export control prescribed by Foreign exchange and Foreign trade act, please consult with ROHM in case of export.

### Precaution Regarding Intellectual Property Rights

1. All information and data including but not limited to application example contained in this document is for reference only. ROHM does not warrant that foregoing information or data will not infringe any intellectual property rights or any other rights of any third party regarding such information or data.
2. ROHM shall not have any obligations where the claims, actions or demands arising from the combination of the Products with other articles such as components, circuits, systems or external equipment (including software).
3. No license, expressly or implied, is granted hereby under any intellectual property rights or other rights of ROHM or any third parties with respect to the Products or the information contained in this document. Provided, however, that ROHM will not assert its intellectual property rights or other rights against you or your customers to the extent necessary to manufacture or sell products containing the Products, subject to the terms and conditions herein.

### Other Precaution

1. This document may not be reprinted or reproduced, in whole or in part, without prior written consent of ROHM.
2. The Products may not be disassembled, converted, modified, reproduced or otherwise changed without prior written consent of ROHM.
3. In no event shall you use in any way whatsoever the Products and the related technical information contained in the Products or this document for any military purposes, including but not limited to, the development of mass-destruction weapons.
4. The proper names of companies or products described in this document are trademarks or registered trademarks of ROHM, its affiliated companies or third parties.

**General Precaution**

1. Before you use our Products, you are requested to carefully read this document and fully understand its contents. ROHM shall not be in any way responsible or liable for failure, malfunction or accident arising from the use of any ROHM's Products against warning, caution or note contained in this document.
2. All information contained in this document is current as of the issuing date and subject to change without any prior notice. Before purchasing or using ROHM's Products, please confirm the latest information with a ROHM sales representative.
3. The information contained in this document is provided on an "as is" basis and ROHM does not warrant that all information contained in this document is accurate and/or error-free. ROHM shall not be in any way responsible or liable for any damages, expenses or losses incurred by you or third parties resulting from inaccuracy or errors of or concerning such information.

Компания «Life Electronics» занимается поставками электронных компонентов импортного и отечественного производства от производителей и со складов крупных дистрибьюторов Европы, Америки и Азии.

С конца 2013 года компания активно расширяет линейку поставок компонентов по направлению коаксиальный кабель, кварцевые генераторы и конденсаторы (керамические, пленочные, электролитические), за счёт заключения дистрибьюторских договоров

Мы предлагаем:

- Конкуренспособные цены и скидки постоянным клиентам.
- Специальные условия для постоянных клиентов.
- Подбор аналогов.
- Поставку компонентов в любых объемах, удовлетворяющих вашим потребностям.
- Приемлемые сроки поставки, возможна ускоренная поставка.
- Доставку товара в любую точку России и стран СНГ.
- Комплексную поставку.
- Работу по проектам и поставку образцов.
- Формирование склада под заказчика.
- Сертификаты соответствия на поставляемую продукцию (по желанию клиента).
- Тестирование поставляемой продукции.
- Поставку компонентов, требующих военную и космическую приемку.
- Входной контроль качества.
- Наличие сертификата ISO.

В составе нашей компании организован Конструкторский отдел, призванный помогать разработчикам, и инженерам.

Конструкторский отдел помогает осуществить:

- Регистрацию проекта у производителя компонентов.
- Техническую поддержку проекта.
- Защиту от снятия компонента с производства.
- Оценку стоимости проекта по компонентам.
- Изготовление тестовой платы монтаж и пусконаладочные работы.



Тел: +7 (812) 336 43 04 (многоканальный)

Email: [org@lifeelectronics.ru](mailto:org@lifeelectronics.ru)