

DA12-M Series

12 Watts

Total Power: 12 Watts
Input Voltage: 90 - 264 Vac
of Outputs: Single



Special Features

- 5 V and 12 V versions
- Medical and ITE Safeties
- Switching wallmount power supply
- Available in interchangeable & fixed ac plug configurations
- CE Mark EMC, LVD & ErP 2011
- Universal AC input
- Fully regulated output
- Overload and short circuit protection
- Thermal protection
- Energy Star and CeC compliant
- Efficiency level V
- Constant voltage
- High MTBF
- Built in EMI filter (CISPR 22 Class B)

Safety

- **UL** 60950, 60601-1
- **cUL** 60950, 60601-1
- **TUV** 60950-1, 60601-1
- **AS/NZS** 60950-1, 60601-1
- **CB** Certificate and report
- **CE** EMC, LVD & ErP 2011 for EU & UK versions
- **PSE** Denan (US only)

Electrical Specifications

Input	
Input range:	90 - 264 Vac (wide range)
Frequency:	47 - 63 Hz
Inrush current:	28 A @ 264 Vac
Input current:	0.25 A rms @ 120 Vac; 0.15 A @ 240 Vac
EMI/RFI:	FCC Part 15, Subpart B Class B & EN55022 (CISPR 22) Class B
Safety ground leakage current:	100 μ A @ 50/60 Hz, 264 Vac input
Output	
Voltage (Vo):	5.0 V and 12.0 V
Voltage regulation:	\pm 5% @ constant voltage mode
Maximum Power (Po):	12 W for 12 V models, 10 W for 5 V models
Hold-up time:	10 ms. typical at full load @ 230 Vac
Overvoltage protection:	Non-latching type
Overload protection:	Output shortcircuit protection auto recover Overload protected @ 150% above maximum rating
Overtemperature protection:	Auto recovery
Output cable/connector barrel polarity:	DC cable with 2.5 mm x 5.5mm barrel plug, 2.1 mm x 5.5 mm available on DC multi-plug version. For others please contact factory. DC plug center +v DC plug outer -v

Environmental Specifications

Operating temperature:	0 ° to +40 °C ambient
Storage temperature:	-40 °C to +85 °C
Electromagnetic susceptibility:	Designed to meet EN55024
Humidity:	Operating; non-condensing 5% to 95% RH
Vibration:	Frequency/PSD: 5 - 350 Hz 0.0001 g ² /Hz 350 - 500 Hz - 6dB/Oct. 500 Hz 0.00005g ² /Hz Acceleration: 0.21 gRMS Duration: 20 min per second

AC Plug Configuration for Fixed Plug

U.S. 2-prong	US
Europe 2-prong	EU
United Kingdom 3-prong	UK
Australia 2-prong	AU

AC Plug Configuration for Interchangeable Plug

U.S. 2-prong	DA-US
Europe 2-prong	DA-EU
United Kingdom 3-prong	DA-UK
Australia 2-prong	DA-AU
C8 - 2 receptacle	DA-C8

Ordering Information - DA12 Adapter

Model Number	Maximum Power	Output Voltage	Minimum Load	Maximum Load	Regulation ²	Ripple P/P (PAR) ³
DA12-120US-M	12 W	12.0 V	0.2 A	1.0	± 5%	120 mV
DA12-120EU-M	12 W	12.0 V	0.2 A	1.0	± 5%	120 mV
DA12-120UK-M	12 W	12.0 V	0.2 A	1.0	± 5%	120 mV
DA12-120AU-M	12 W	12.0 V	0.2 A	1.0	± 5%	120 mV
DA12-120MP-M*	12 W	12.0 V	0.2 A	1.0	± 5%	120 mV
DA12-120MP-M2.1**	12 W	12.0 V	0.2 A	1.0	± 5%	120 mV
DA12-050US-M	10 W	5.0 V	0.2 A	2.0	± 5%	50 mV
DA12-050EU-M	10 W	5.0 V	0.2 A	2.0	± 5%	50 mV
DA12-050UK-M	10 W	5.0 V	0.2 A	2.0	± 5%	50 mV
DA12-050AU-M	10 W	5.0 V	0.2 A	2.0	± 5%	50 mV
DA12-050MP-M*	10 W	5.0 V	0.2 A	2.0	± 5%	50 mV
DA12-050MP-M2.1**	10 W	5.0 V	0.2 A	2.0	± 5%	50 mV

* Interchangeable version - AC Plugs must be purchased separately to be used with DA12-120MP-M and DA12-050MP-M

** 2.1 mm x 5.5 mm barrel plug

Ordering Information - DA12 Interchangeable Plug

Model Number	
DA-US	DA-C8
DA-EU	DA-JP
DA-UK	DA-CH
DA-AU	DA-KR
DA-All Includes DA-US, DA-EU, DA-UK, and DA-AU	

1. Peak current lasting < 30 seconds with a maximum 10% duty cycle.
2. At 25 °C including initial tolerance, line voltage, load currents and output voltages adjusted to factory settings.
3. Peak-to-peak with 20 mHz bandwidth and 10 μF in parallel with a 0.1 μF capacitor at rated line voltage and load ranges.
4. Power supplies will operate with no-load.

Mechanical Drawings

DA12-XXXUS-M



DA12-XXXAU-M



DA12-XXXEU-M



DA12-XXXUK-M

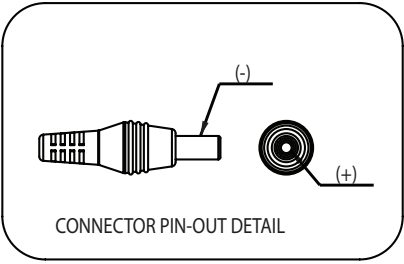
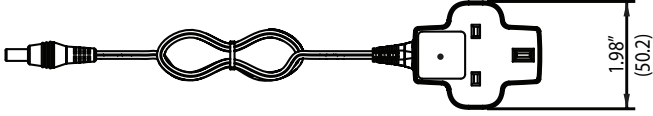
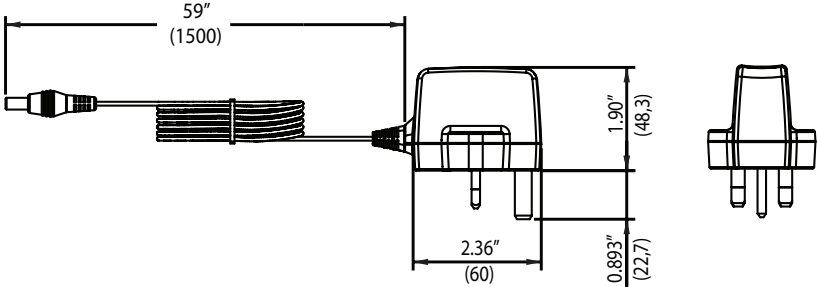

DA12-MP Interchangeable Plug Adapter

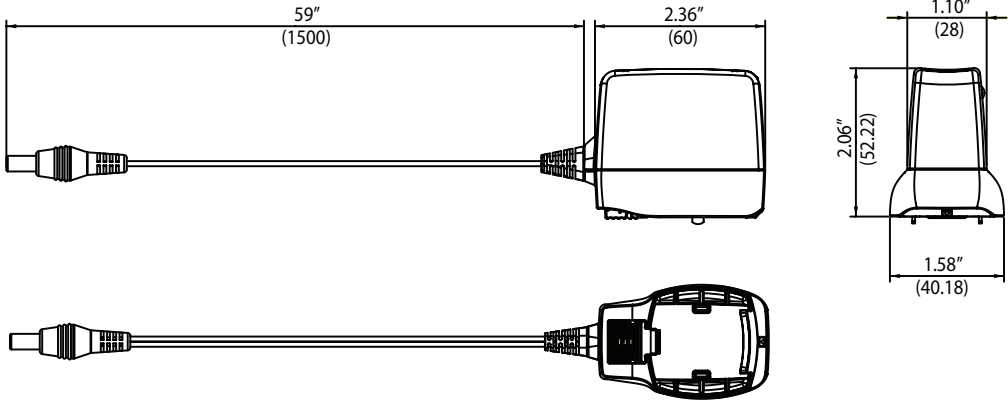

*Can be inserted straight or 90°

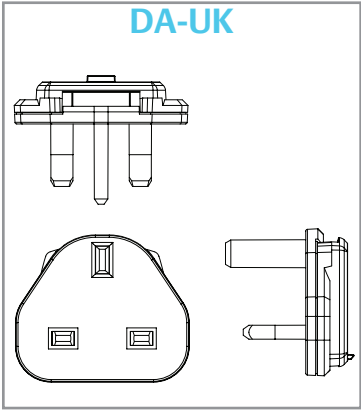

*Can be inserted straight or 90°

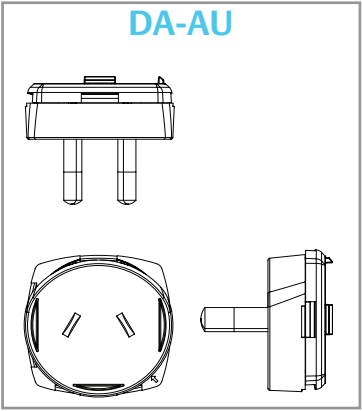

*Can be inserted straight or 90°

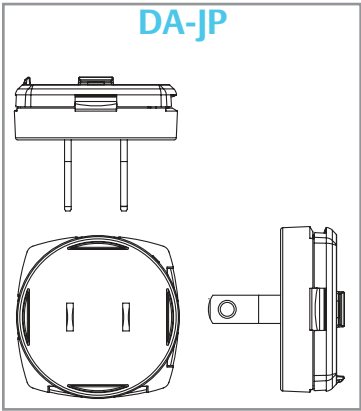

*Can be inserted straight or 90°

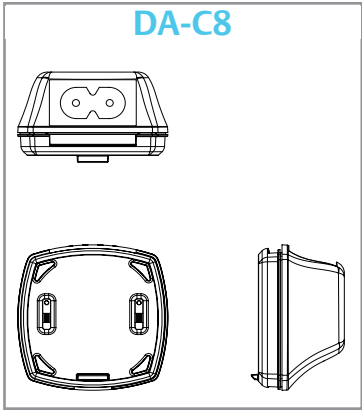

Notes:

1. Specifications subject to change without notice.
2. All dimensions in inches (mm), tolerance is $\pm .02$ ".
3. Weight: 0.25 lb/0.114 kg
4. Warranty: 2 years

Americas

5810 Van Allen Way
Carlsbad, CA 92008
USA
Telephone: +1 760 930 4600
Facsimile: +1 760 930 0698

Europe (UK)

Waterfront Business Park
Merry Hill, Dudley
West Midlands, DY5 1LX
United Kingdom
Telephone: +44 (0) 1384 842 211
Facsimile: +44 (0) 1384 843 355

Asia (HK)

14/F, Lu Plaza
2 Wing Yip Street
Kwun Tong, Kowloon
Hong Kong
Telephone: +852 2176 3333
Facsimile: +852 2176 3888

For global contact, visit:

www.Emerson.com/EmbeddedPower
[techsupport.embeddedpower](mailto:techsupport.embeddedpower@emerson.com)
[@emerson.com](mailto:techsupport.embeddedpower@emerson.com)

While every precaution has been taken to ensure accuracy and completeness in this literature, Emerson Network Power assumes no responsibility, and disclaims all liability for damages resulting from use of this information or for any errors or omissions.

Emerson Network Power.
The global leader in enabling
business-critical continuity.

- AC Power
- Connectivity
- DC Power
- Embedded Computing
- **Embedded Power**
- Monitoring
- Outside Plant
- Power Switching & Controls
- Precision Cooling
- Racks & Integrated Cabinets
- Services
- Surge Protection

EmersonNetworkPower.com

Emerson Network Power and the Emerson Network Power logo are trademarks and service marks of Emerson Electric Co.
©2011 Emerson Electric Co.

Компания «Life Electronics» занимается поставками электронных компонентов импортного и отечественного производства от производителей и со складов крупных дистрибьюторов Европы, Америки и Азии.

С конца 2013 года компания активно расширяет линейку поставок компонентов по направлению коаксиальный кабель, кварцевые генераторы и конденсаторы (керамические, пленочные, электролитические), за счёт заключения дистрибьюторских договоров

Мы предлагаем:

- Конкурентоспособные цены и скидки постоянным клиентам.
- Специальные условия для постоянных клиентов.
- Подбор аналогов.
- Поставку компонентов в любых объемах, удовлетворяющих вашим потребностям.
- Приемлемые сроки поставки, возможна ускоренная поставка.
- Доставку товара в любую точку России и стран СНГ.
- Комплексную поставку.
- Работу по проектам и поставку образцов.
- Формирование склада под заказчика.
- Сертификаты соответствия на поставляемую продукцию (по желанию клиента).
- Тестирование поставляемой продукции.
- Поставку компонентов, требующих военную и космическую приемку.
- Входной контроль качества.
- Наличие сертификата ISO.

В составе нашей компании организован Конструкторский отдел, призванный помогать разработчикам, и инженерам.

Конструкторский отдел помогает осуществить:

- Регистрацию проекта у производителя компонентов.
- Техническую поддержку проекта.
- Защиту от снятия компонента с производства.
- Оценку стоимости проекта по компонентам.
- Изготовление тестовой платы монтаж и пусконаладочные работы.



Тел: +7 (812) 336 43 04 (многоканальный)

Email: org@lifeelectronics.ru