

Quad 2 channel multiplexer (3-state)

Datasheet – production data

Features

- High speed: $t_{PD} = 4.8 \text{ ns (typ.)}$ at $V_{CC} = 5 \text{ V}$
- Low power dissipation
 $I_{CC} = 4 \mu\text{A (max.)}$ at $T_A = 25 \text{ }^\circ\text{C}$
- Compatible with TTL outputs
 $V_{IH} = 2 \text{ V (min.)}$, $V_{IL} = 0.8 \text{ V (max.)}$
- Power-down protection on inputs and outputs
- Symmetrical output impedance
 $|I_{OH}| = I_{OL} = 8 \text{ mA (min.)}$
- Balanced propagation delays: $t_{PLH} \cong t_{PHL}$
- Operating voltage range: $V_{CC(opr)} = 4.5 \text{ to } 5.5 \text{ V}$
- Pin and function compatible with 74 series 257
- Improved latch-up immunity
- Low noise: $V_{OLP} = 0.8 \text{ V (max.)}$

Description

The 74VHCT257A is an advanced high-speed CMOS quad 2 channel multiplexer (3-state) fabricated with sub-micron silicon gate and double-layer metal wiring C²MOS technology.

It is composed of four independent 2 channel multiplexers with common select and enable input (\overline{OE}). The VHCT257A is a non-inverting multiplexer.

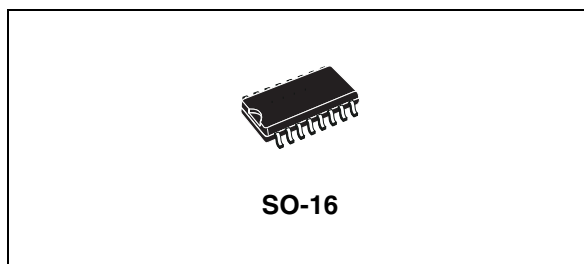

Table 1. Order code

Package	Tape and reel
SO-16	74VHCT257AMTR

When the enable input is held “high”, all outputs become high impedance state. If the select input is held “low”, “A” data is selected, when select input is “high”, “B” data is chosen.

Power-down protection is provided on all inputs and outputs and 0 to 7 V can be accepted on inputs with no regard to the supply voltage. This device can be used to interface 5 V to 3 V since all inputs are equipped with TTL threshold.

All inputs and outputs are equipped with protection circuits against static discharge, giving them 2 KV ESD immunity and transient excess voltage.

Figure 1. Pin connection and IEC logic symbols

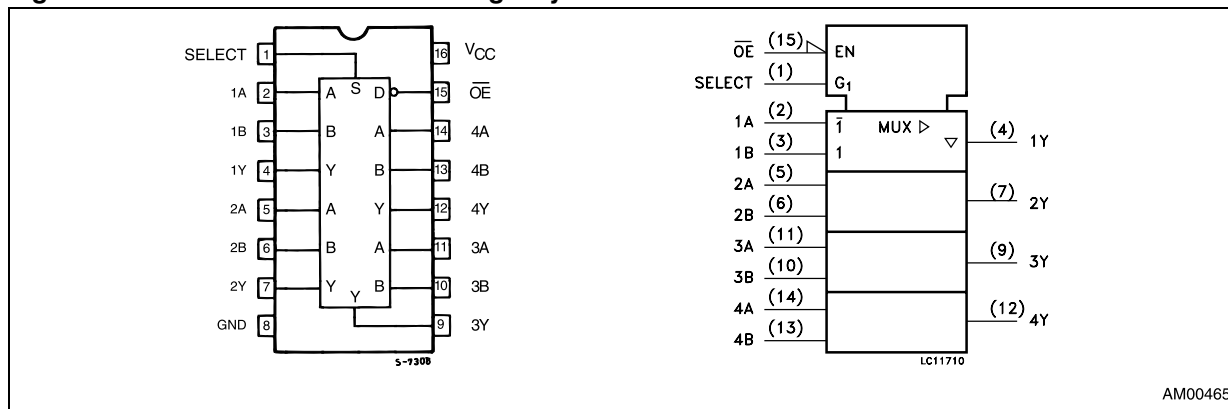

1 Input equivalent circuit

Figure 2. Input equivalent circuit

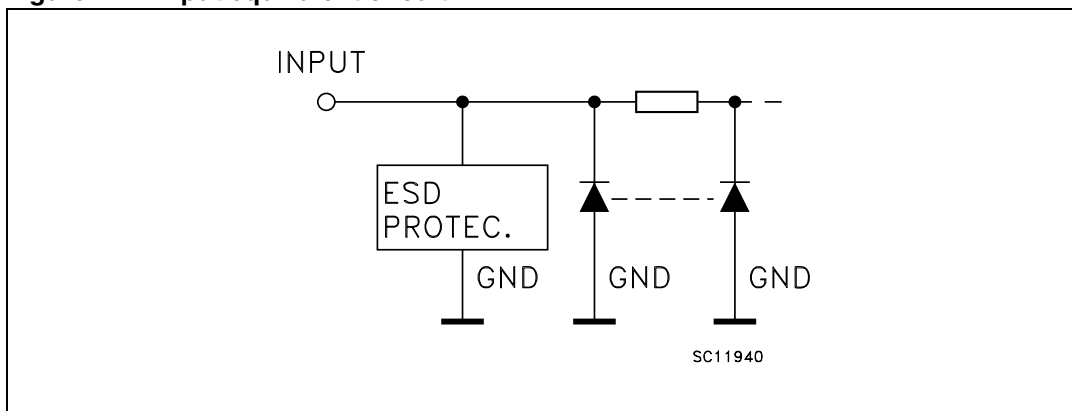

2 Pin settings

Table 2. Pin description

Pin No	Symbol	Name and function
1	SELECT	Common data select inputs
2, 5, 11, 14	1A to 4A	Data inputs from source A
3, 6, 10, 13	1B to 4B	Data inputs from source B
4, 7, 9, 12	1Y to 4Y	3-state multiplexer outputs
15	$\overline{\text{OE}}$	3-state output enable inputs (active LOW)
8	GND	Ground (0 V)
16	V_{CC}	Positive supply voltage

Table 3. Truth table

Inputs				Output
$\overline{\text{OE}}$	SELECT	A	B	Y
H	$X^{(1)}$	$X^{(1)}$	$X^{(1)}$	$Z^{(2)}$
L	L	L	$X^{(1)}$	L
L	L	H	$X^{(1)}$	H
L	H	$X^{(1)}$	L	L
L	H	$X^{(1)}$	H	H

1. "Don't care".
2. High impedance.

Figure 3. Logic diagram

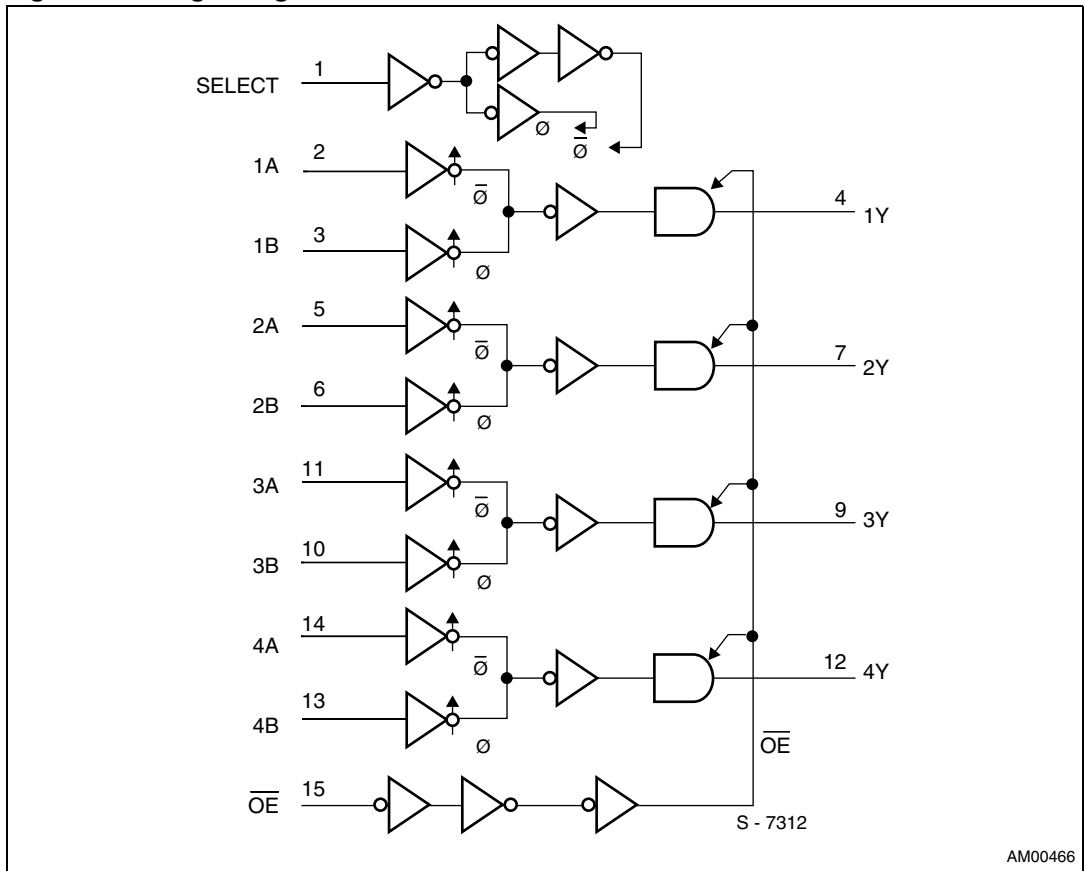

1. This logic diagram has not be used to estimate propagation delays.

3 Maximum ratings

Table 4. Absolute maximum ratings

Symbol	Parameter	Value	Unit
V_{CC}	Supply voltage	-0.5 to +7.0	V
V_I	DC input voltage	-0.5 to +7.0	V
V_O	DC output voltage ⁽¹⁾	-0.5 to +7.0	V
V_O	DC output voltage ⁽²⁾	-0.5 to $V_{CC} + 0.5$	V
I_{IK}	DC input diode current	- 20	mA
I_{OK}	DC output diode current	± 20	mA
I_O	DC output current	± 25	mA
I_{CC} or I_{GND}	DC V_{CC} or ground current	± 50	mA
T_{stg}	Storage temperature	-65 to +150	°C
T_L	Lead temperature (10 sec.)	300	°C

1. Absolute maximum ratings are those values beyond which damage to the device may occur. Functional operation under these conditions is not implied: output in OFF state.
2. Absolute maximum ratings are those values beyond which damage to the device may occur. Functional operation under these conditions is not implied: high or low state.

Table 5. Recommended operating conditions

Symbol	Parameter	Value	Unit
V_{CC}	Supply voltage	4.5 to 5.5	V
V_I	Input voltage	0 to 5.5	V
V_O	Output voltage ⁽¹⁾	0 to 5.5	V
V_O	Output voltage ⁽²⁾	0 to V_{CC}	V
T_{op}	Operating temperature	-55 to 125	°C
dt/dv	Input rise and fall time ⁽³⁾ ($V_{CC} = 5.0 \pm 0.5$ V)	0 to 20	ns/V

1. Output in OFF state.
2. High or low state.
3. V_{IN} from 0.8 V to 2 V.

4 Electrical characteristics

Table 6. DC specifications

Symbol	Parameter	Test condition		Value						Unit	
		V _{CC} (V)		T _A = 25 °C			-40 to 85 °C		-55 to 125 °C		
				Min.	Typ.	Max.	Min.	Max.	Min.		Max.
V _{IH}	High level input voltage	4.5 to 5.5		2			2		2		V
V _{IL}	Low level input voltage	4.5 to 5.5				0.8		0.8		0.8	V
V _{OH}	High level output voltage	4.5	I _O = -50 μA	4.4	4.5		4.4		4.4		V
		4.5	I _O = -8 mA	3.94			3.8		3.7		
V _{OL}	Low level output voltage	4.5	I _O = 50 μA		0.0	0.1		0.1		0.1	V
		4.5	I _O = 8 mA			0.36		0.44		0.55	
I _{OZ}	High impedance output leakage current	5.5	V _I = V _{IH} or V _{IL} V _O = 0 V to 5.5 V			±0.25		±2.5		±2.5	μA
I _I	Input leakage current	0 to 5.5	V _I = 5.5 V or GND			±0.1		±1.0		±1.0	μA
I _{CC}	Quiescent supply current	5.5	V _I = V _{CC} or GND			4		40		40	μA
+I _{CC}	Additional worst case supply current	5.5	One input at 3.4 V, other input at V _{CC} or GND			1.35		1.5		1.5	mA
I _{OPD}	Output leakage current	0	V _{OUT} = 5.5 V			0.5		5.0		5.0	μA

Table 7. AC electrical characteristics (input $t_r = t_f = 3$ ns)

Symbol	Parameter	Test condition		Value						Unit	
		$V_{CC}^{(1)}$ (V)	C_L (pF)	$T_A = 25\text{ }^\circ\text{C}$			$-40\text{ to }85\text{ }^\circ\text{C}$		$-55\text{ to }125\text{ }^\circ\text{C}$		
				Min.	Typ.	Max.	Min.	Max.	Min.		Max.
t_{PLH} t_{PHL}	Propagation delay time A, B, to Y	5.0	15		4.8	7.0	1.0	8.0	1.0	8.0	ns
		5.0	50		5.5	8.0	1.0	9.0	1.0	9.0	
t_{PLH} t_{PHL}	Propagation delay time SELECT to Y	5.0	15		6.0	6.8	1.0	8.0	1.0	8.0	ns
		5.0	50		7.0	8.8	1.0	10.0	1.0	10.0	
t_{PZL} t_{PZH}	Output enable time	5.0	15		5.8	6.8	1.0	8.0	1.0	8.0	ns
		5.0	50		6.5	8.8	1.0	10.0	1.0	10.0	
t_{PLZ} t_{PHZ}	Output disable time	5.0	50		5.7	7.9	1.0	9.0	1.0	9.0	ns

1. Voltage range is $5.0\text{ V} \pm 0.5\text{ V}$.

Table 8. Capacitive characteristics

Symbol	Parameter	Test condition		Value						Unit	
				$T_A = 25\text{ }^\circ\text{C}$			$-40\text{ to }85\text{ }^\circ\text{C}$		$-55\text{ to }125\text{ }^\circ\text{C}$		
				Min.	Typ.	Max.	Min.	Max.	Min.		Max.
C_{IN}	Input capacitance				4	10		10		10	pF
C_{OUT}	Output capacitance				6						pF
C_{PD}	Power dissipation capacitance ⁽¹⁾				23						pF

1. CPD is defined as the value of the IC's internal equivalent capacitance which is calculated from the operating current consumption without load. (Refer to [Figure 5: Test circuit](#)). Average operating current can be obtained by equation:
 $I_{CC(opr)} = C_{PD} \times V_{CC} \times f_{IN} + I_{CC}/4$ (per channel).

Table 9. Dynamic switching characteristics

Symbol	Parameter	Test condition		Value						Unit	
		V_{CC} (V)		$T_A = 25\text{ }^\circ\text{C}$			$-40\text{ to }85\text{ }^\circ\text{C}$		$-55\text{ to }125\text{ }^\circ\text{C}$		
				Min.	Typ.	Max.	Min.	Max.	Min.		Max.
V_{OLP} V_{OLV}	Dynamic low voltage quiet output ^{(1),(2)}	5.0	$C_L = 50\text{ pF}$		0.3	0.8					V
				-0.8	-0.3						
V_{IHD}	Dynamic high voltage input ^{(1),(3)}	5.0		2.0							
V_{ILD}	Dynamic low voltage input ^{(1),(3)}	5.0				0.8					

1. Worst case package.

2. Max. number of outputs defined as (n). Data inputs are driven 0 V to 3.0 V, (n-1) outputs switching and one output at GND.

3. Max. number of data inputs (n) switching. (n-1) switching 0 V to 3.0 V. Inputs under test switching: 3.0 V to threshold (V_{ILD}), 0 V to threshold (V_{IHD}), $f = 1\text{ MHz}$.

5 Test circuit

Figure 4. Test circuit

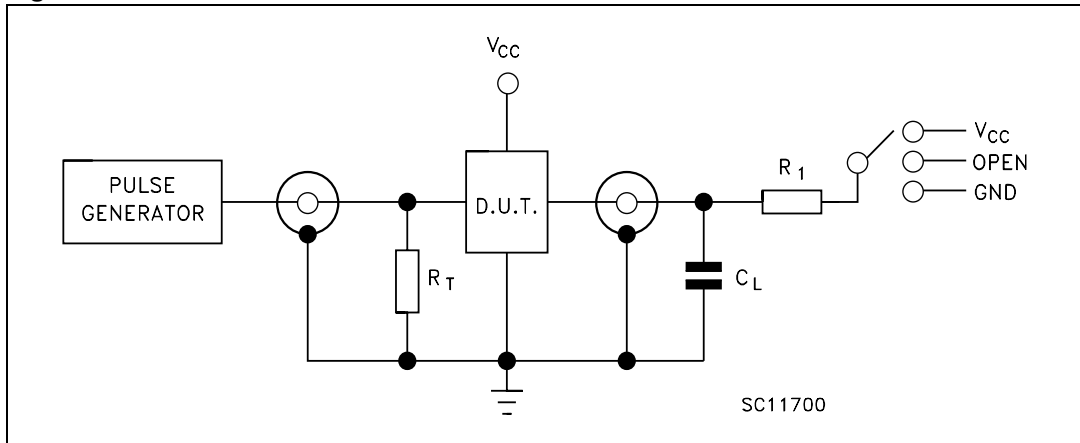

Table 10. Switch configuration

Type	Input		Load		Switch position		
	V_I	t_p, t_f	C_L	R_L	t_{PHL}, t_{PLH}	t_{PZH}, t_{PHZ}	t_{PZL}, t_{PLZ}
74VHCT257	3 V	6 ns	50 pF	1 k Ω	Open	GND	V_{CC}

$C_L = 15/ 50$ pF or equivalent (includes jig and probe capacitance).

$R_L = R_1 = 1$ K Ω or equivalent.

$R_T = Z_{OUT}$ of pulse generator (typically 50 Ω).

6 Waveforms

**Figure 5. Waveform - propagation delays for inverting conditions
(f = 1 mhz; 50% duty cycle)**

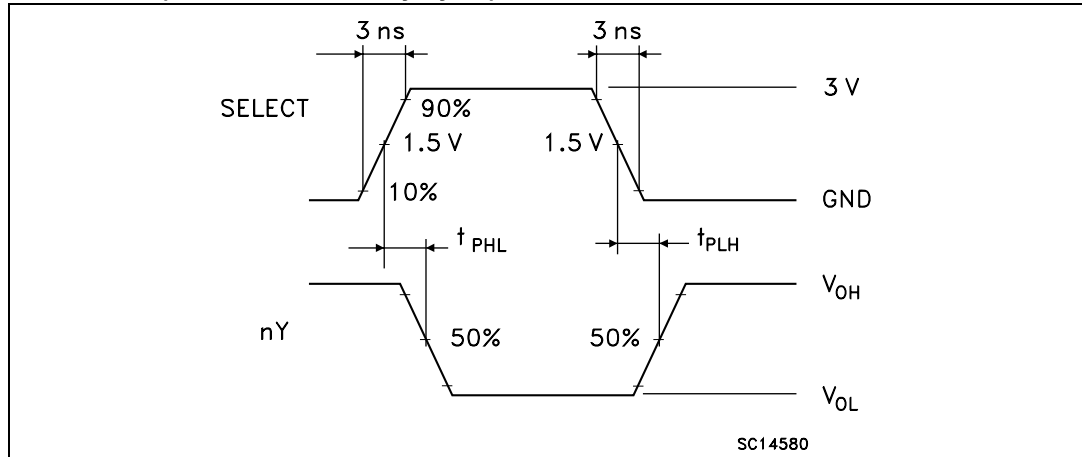

**Figure 6. Waveform - propagation delays for non-inverting conditions
(f = 1 MHz; 50% duty cycle)**

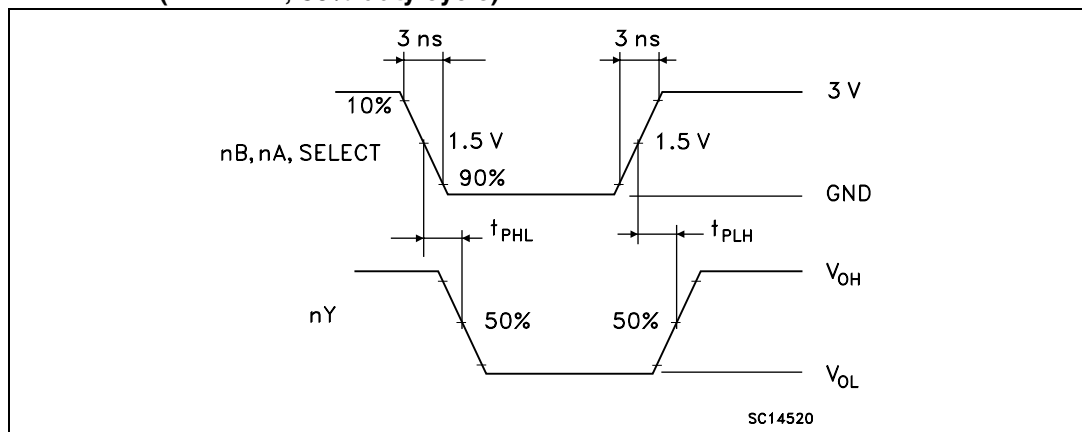
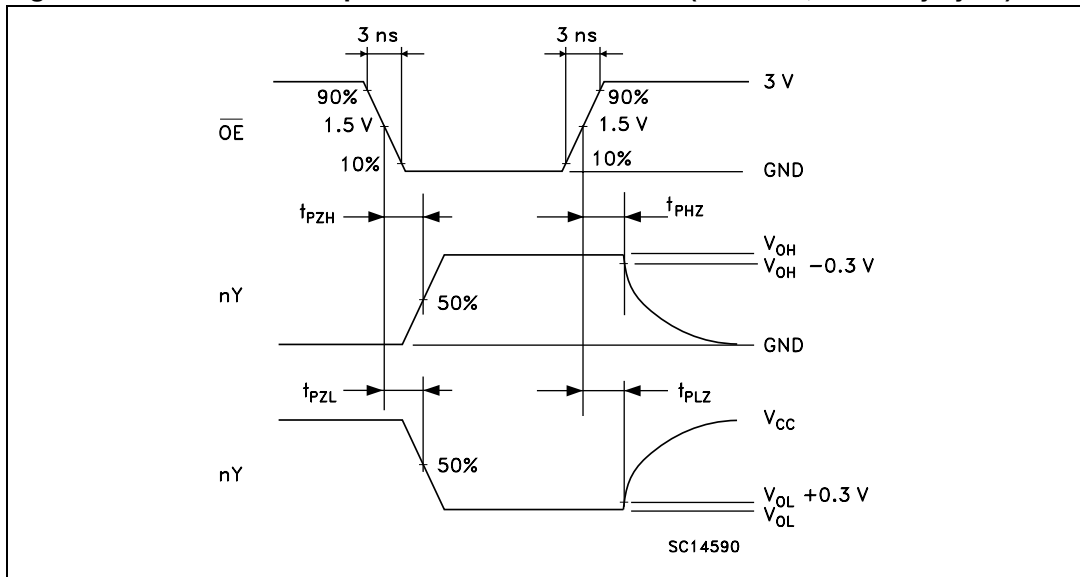

Figure 7. Waveform - output enable and disable time (f = 1 MHz; 50% duty cycle)



7 Package information

In order to meet environmental requirements, ST offers these devices in different grades of ECOPACK[®] packages, depending on their level of environmental compliance. ECOPACK specifications, grade definitions and product status are available at: www.st.com. ECOPACK is an ST trademark.

Figure 8. SO-16 package outline

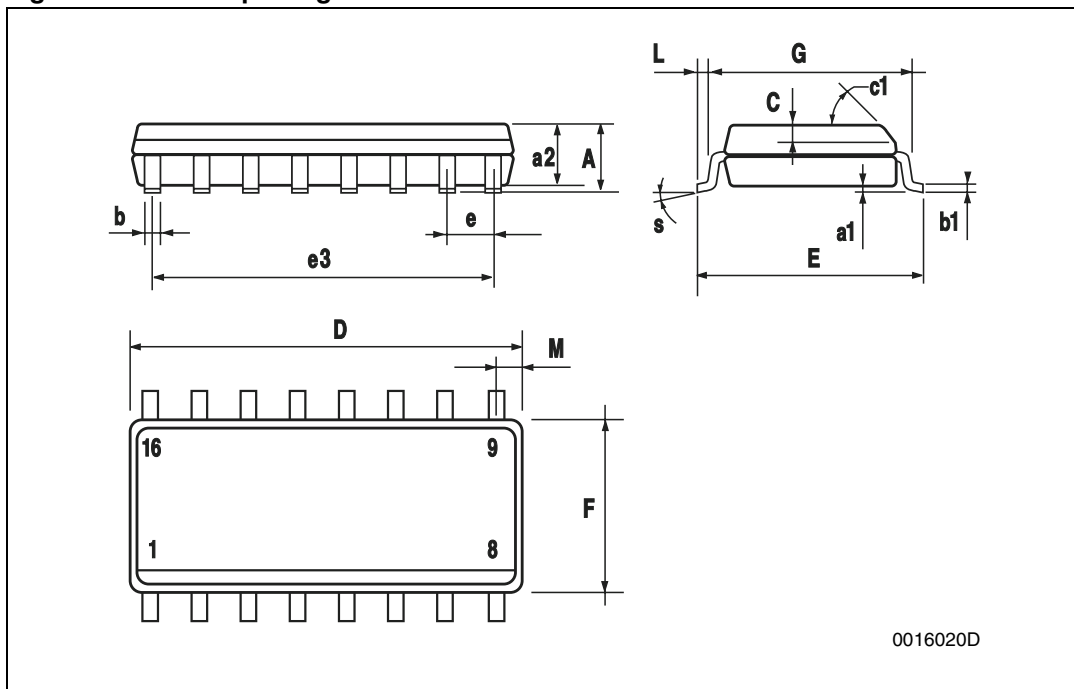

0016020D

Table 11. SO-16 mechanical data

Symbol	Dimensions					
	mm			inch		
	Min.	Typ.	Max.	Min.	Typ.	Max.
A			1.75			0.068
a1	0.1		0.25	0.004		0.010
a2			1.64			0.063
b	0.35		0.46	0.013		0.018
b1	0.19		0.25	0.007		0.010
C		0.5		0.019		
c1	45° (typ.)					
D	9.8		10	0.385		0.393
E	5.8		6.2	0.228		0.244
e		1.27			0.050	
e3		8.89			0.350	
F	3.8		4.0	0.149		0.157
G	4.6		5.3	0.181		0.208
L	0.5		1.27	0.019		0.050
M			0.62			0.024
S	8° (max.)					

Figure 9. SO-16 tape and reel

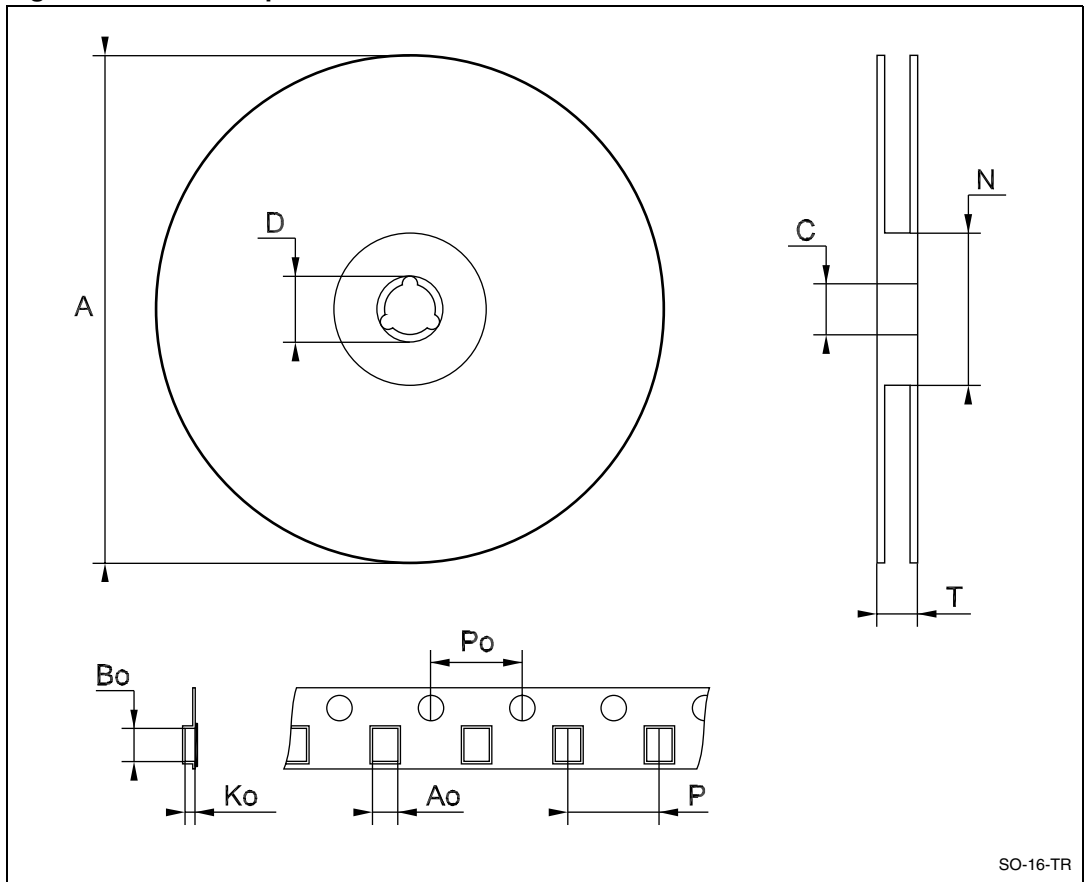

1. drawing not in scale.

Table 12. SO-16 tape and reel mechanical data

Symbol	Dimensions					
	mm			inch		
	Min.	Typ.	Max.	Min.	Typ.	Max.
A			330			12.992
C	12.8		13.2	0.504		0.519
D	20.2			0.795		
N	60			2.362		
T			22.4			0.882
Ao	6.45		6.65	0.254		0.262
Bo	10.3		10.5	0.406		0.414
Ko	2.1		2.3	0.082		0.090
Po	3.9		4.1	0.153		0.161
P	7.9		8.1	0.311		0.319

Revision history

Table 13. Document revision history

Date	Revision	Changes
16-Dec-2004	3	Order Codes Revision - pag. 1.
21-Nov-2012	4	Removed 74VHCT257ATTR device and TSSOP package from document. Replaced SOP by SO16 package on page 1. Added numbered headings to Section 1: Input equivalent circuit to Section 7: Package information . Updated Table 10 (removed 74HC257 device, 74HCT257 replaced by 74VHCT257 device). Updated Section 7: Package information , added ECOPACK®. Minor text corrections throughout document.

Please Read Carefully:

Information in this document is provided solely in connection with ST products. STMicroelectronics NV and its subsidiaries ("ST") reserve the right to make changes, corrections, modifications or improvements, to this document, and the products and services described herein at any time, without notice.

All ST products are sold pursuant to ST's terms and conditions of sale.

Purchasers are solely responsible for the choice, selection and use of the ST products and services described herein, and ST assumes no liability whatsoever relating to the choice, selection or use of the ST products and services described herein.

No license, express or implied, by estoppel or otherwise, to any intellectual property rights is granted under this document. If any part of this document refers to any third party products or services it shall not be deemed a license grant by ST for the use of such third party products or services, or any intellectual property contained therein or considered as a warranty covering the use in any manner whatsoever of such third party products or services or any intellectual property contained therein.

UNLESS OTHERWISE SET FORTH IN ST'S TERMS AND CONDITIONS OF SALE ST DISCLAIMS ANY EXPRESS OR IMPLIED WARRANTY WITH RESPECT TO THE USE AND/OR SALE OF ST PRODUCTS INCLUDING WITHOUT LIMITATION IMPLIED WARRANTIES OF MERCHANTABILITY, FITNESS FOR A PARTICULAR PURPOSE (AND THEIR EQUIVALENTS UNDER THE LAWS OF ANY JURISDICTION), OR INFRINGEMENT OF ANY PATENT, COPYRIGHT OR OTHER INTELLECTUAL PROPERTY RIGHT.

UNLESS EXPRESSLY APPROVED IN WRITING BY TWO AUTHORIZED ST REPRESENTATIVES, ST PRODUCTS ARE NOT RECOMMENDED, AUTHORIZED OR WARRANTED FOR USE IN MILITARY, AIR CRAFT, SPACE, LIFE SAVING, OR LIFE SUSTAINING APPLICATIONS, NOR IN PRODUCTS OR SYSTEMS WHERE FAILURE OR MALFUNCTION MAY RESULT IN PERSONAL INJURY, DEATH, OR SEVERE PROPERTY OR ENVIRONMENTAL DAMAGE. ST PRODUCTS WHICH ARE NOT SPECIFIED AS "AUTOMOTIVE GRADE" MAY ONLY BE USED IN AUTOMOTIVE APPLICATIONS AT USER'S OWN RISK.

Resale of ST products with provisions different from the statements and/or technical features set forth in this document shall immediately void any warranty granted by ST for the ST product or service described herein and shall not create or extend in any manner whatsoever, any liability of ST.

ST and the ST logo are trademarks or registered trademarks of ST in various countries.

Information in this document supersedes and replaces all information previously supplied.

The ST logo is a registered trademark of STMicroelectronics. All other names are the property of their respective owners.

© 2012 STMicroelectronics - All rights reserved

STMicroelectronics group of companies

Australia - Belgium - Brazil - Canada - China - Czech Republic - Finland - France - Germany - Hong Kong - India - Israel - Italy - Japan - Malaysia - Malta - Morocco - Philippines - Singapore - Spain - Sweden - Switzerland - United Kingdom - United States of America

www.st.com



Компания «Life Electronics» занимается поставками электронных компонентов импортного и отечественного производства от производителей и со складов крупных дистрибьюторов Европы, Америки и Азии.

С конца 2013 года компания активно расширяет линейку поставок компонентов по направлению коаксиальный кабель, кварцевые генераторы и конденсаторы (керамические, пленочные, электролитические), за счёт заключения дистрибьюторских договоров

Мы предлагаем:

- Конкурентоспособные цены и скидки постоянным клиентам.
- Специальные условия для постоянных клиентов.
- Подбор аналогов.
- Поставку компонентов в любых объемах, удовлетворяющих вашим потребностям.
- Приемлемые сроки поставки, возможна ускоренная поставка.
- Доставку товара в любую точку России и стран СНГ.
- Комплексную поставку.
- Работу по проектам и поставку образцов.
- Формирование склада под заказчика.
- Сертификаты соответствия на поставляемую продукцию (по желанию клиента).
- Тестирование поставляемой продукции.
- Поставку компонентов, требующих военную и космическую приемку.
- Входной контроль качества.
- Наличие сертификата ISO.

В составе нашей компании организован Конструкторский отдел, призванный помогать разработчикам, и инженерам.

Конструкторский отдел помогает осуществить:

- Регистрацию проекта у производителя компонентов.
- Техническую поддержку проекта.
- Защиту от снятия компонента с производства.
- Оценку стоимости проекта по компонентам.
- Изготовление тестовой платы монтаж и пусконаладочные работы.



Тел: +7 (812) 336 43 04 (многоканальный)
Email: org@lifeelectronics.ru