

Limit value switches - MINI MCR-2-UI-REL-PT - 2902035

Please be informed that the data shown in this PDF Document is generated from our Online Catalog. Please find the complete data in the user's documentation. Our General Terms of Use for Downloads are valid (<http://phoenixcontact.com/download>)



Universally configurable limit value switch with PDT relay output and plug-in connection technology for switching analog limit values. Configurable via DIP switch or software, push-in connection technology.

Product Description

Universally configurable limit value switch with PDT relay output and plug-in connection technology for switching analog limit values. Current signals between 0 mA ... 24 mA and voltage signals between 0 V ... 12 V can be processed on the input side. A relay with PDT contact is available on the output side. It is then possible to switch loads up to 250 V AC/DC and max. 6 A. You can configure the device using one of the free software solutions. Default settings can also be made directly on the device by simply using the DIP switches (see configuration table). The measuring transducer supports fault monitoring and NFC communication.



Key Commercial Data

Packing unit	1 pc
Weight per Piece (excluding packing)	120.0 g
Custom tariff number	85437090
Country of origin	Germany

Technical data

Note

Utilization restriction	EMC: class A product, see manufacturer's declaration in the download area
-------------------------	---

Dimensions

Width	6.2 mm
Height	110.5 mm
Depth	120.5 mm

Ambient conditions

Ambient temperature (operation)	-40 °C ... 70 °C
---------------------------------	------------------

Limit value switches - MINI MCR-2-UI-REL-PT - 2902035

Technical data

Ambient conditions

Ambient temperature (storage/transport)	-40 °C ... 85 °C
Degree of protection	IP20

Input data

Configurable/programmable	Yes
Voltage input signal	0 V ... 10 V (via DIP switch)
	0 V ... 12 V (via DIP switch)
Current input signal	0 mA ... 20 mA (via DIP switch)
	0 mA ... 24 mA (Can be set via software)
Max. input voltage	12 V
Max. input current	24 mA
Input resistance of voltage input	> 120 kΩ
Input resistance current input	approx. 50 Ω

Switching output

Output name	Relay output
Contact type	1 PDT
Contact material	AgSnO ₂ , hard gold-plated
Maximum switching voltage	250 V AC
	240 V AC (UL)
Limiting continuous current	6 A
Min. switching current	100 mA (12 V DC)
Mechanical service life	2 x 10 ⁷ cycles
Setting range of the response delay	0 s ... 10 s (can be set freely via software)
Internal hysteresis	can be set freely via software
Max. switching current	6 A (for 250 V AC)

Power supply

Nominal supply voltage	24 V DC
Supply voltage range	9.6 V DC ... 30 V DC (The DIN rail bus connector (ME 6,2 TBUS-2 1,5/5-ST-3,81 GN, Order No. 2869728) can be used to bridge the supply voltage. It can be snapped onto a 35 mm DIN rail according to EN 60715))
Typical current consumption	40 mA (12 V DC)
	20 mA (24 V DC)
Power consumption	≤ 0.5 W

Connection data

Connection method	Push-in connection
Single conductor/terminal point, solid, with ferrule, min.	0.14 mm ²
Single conductor/terminal point, solid, with ferrule, max.	2.5 mm ²

Limit value switches - MINI MCR-2-UI-REL-PT - 2902035

Technical data

Connection data

Single conductor/terminal point, solid, without ferrule, min.	0.14 mm ²
Single conductor/terminal point, solid, without ferrule, max.	2.5 mm ²
Conductor cross section flexible min.	0.14 mm ²
Conductor cross section flexible max.	2.5 mm ²
Min. AWG conductor cross section, flexible	24
Max. AWG conductor cross section, flexible	12
Stripping length	10 mm

General

No. of channels	1
Maximum transmission error	0.1 % (of final value)
Maximum temperature coefficient	0.01 %/K
Switching point accuracy	< 0.1 %
Status display	Yellow LED (switching output)
Electrical isolation	Reinforced insulation in accordance with IEC 61010-1
Overvoltage category	II
Pollution degree	2
Rated insulation voltage	300 V (effective)
Test voltage, input/output/supply	3 kV (50 Hz, 1 min.)
Electromagnetic compatibility	Conformance with EMC Directive 2004/108/EC
Noise emission	EN 61000-6-4
Noise immunity	EN 61000-6-2 When being exposed to interference, there may be minimal deviations.
Color	gray
Housing material	PBT
Mounting position	any
Assembly instructions	The T connector can be used to bridge the supply voltage. It can be snapped onto a 35 mm DIN rail according to EN 60715.
Conformance	CE-compliant
ATEX	# II 3 G Ex nA nC IIC T4 Gc X
UL, USA / Canada	UL 508 Listed
	Class I, Div. 2, Groups A, B, C, D T4A
GL	GL applied for

Classifications

eCl@ss

eCl@ss 4.0	27210120
------------	----------

Limit value switches - MINI MCR-2-UI-REL-PT - 2902035

Classifications

eCl@ss

eCl@ss 4.1	27210120
eCl@ss 5.0	27210120
eCl@ss 5.1	27210120
eCl@ss 6.0	27210120
eCl@ss 7.0	27210120
eCl@ss 8.0	27210122

ETIM

ETIM 3.0	EC001485
ETIM 4.0	EC001446
ETIM 5.0	EC002654

UNSPSC

UNSPSC 6.01	30211506
UNSPSC 7.0901	39121008
UNSPSC 11	39121008
UNSPSC 12.01	39121008
UNSPSC 13.2	39121008

Drawings

Block diagram

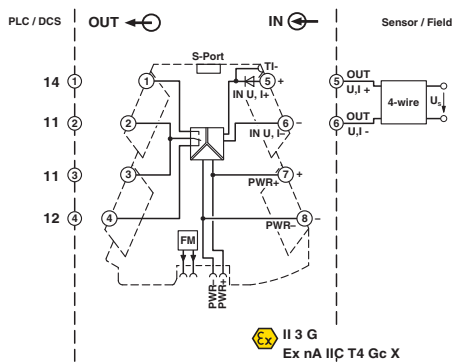

Pictogram

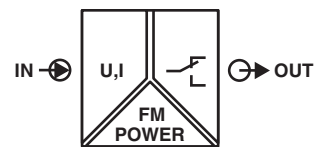

Компания «Life Electronics» занимается поставками электронных компонентов импортного и отечественного производства от производителей и со складов крупных дистрибьюторов Европы, Америки и Азии.

С конца 2013 года компания активно расширяет линейку поставок компонентов по направлению коаксиальный кабель, кварцевые генераторы и конденсаторы (керамические, пленочные, электролитические), за счёт заключения дистрибьюторских договоров

Мы предлагаем:

- Конкурентоспособные цены и скидки постоянным клиентам.
- Специальные условия для постоянных клиентов.
- Подбор аналогов.
- Поставку компонентов в любых объемах, удовлетворяющих вашим потребностям.
- Приемлемые сроки поставки, возможна ускоренная поставка.
- Доставку товара в любую точку России и стран СНГ.
- Комплексную поставку.
- Работу по проектам и поставку образцов.
- Формирование склада под заказчика.
- Сертификаты соответствия на поставляемую продукцию (по желанию клиента).
- Тестирование поставляемой продукции.
- Поставку компонентов, требующих военную и космическую приемку.
- Входной контроль качества.
- Наличие сертификата ISO.

В составе нашей компании организован Конструкторский отдел, призванный помогать разработчикам, и инженерам.

Конструкторский отдел помогает осуществить:

- Регистрацию проекта у производителя компонентов.
- Техническую поддержку проекта.
- Защиту от снятия компонента с производства.
- Оценку стоимости проекта по компонентам.
- Изготовление тестовой платы монтаж и пусконаладочные работы.



Тел: +7 (812) 336 43 04 (многоканальный)

Email: org@lifeelectronics.ru