

XL60 Supercapacitors

Cylindrical cells



Description

Eaton PowerStor supercapacitors are unique, ultra-high capacitance devices utilizing electrochemical double layer capacitor (EDLC) construction combined with new, high performance materials. This combination of advanced technologies allows Eaton to offer a wide variety of capacitor solutions tailored to specific applications. The XL60 supercapacitor cells offers high energy and power in a standardized form factor. Terminal design is optimized for high reliability and low contact resistance.

Features and benefits

- Long life energy storage, up to 20 years
- Ultra low ESR for very high power density
- Wide operating temperature range
- Maintenance free
- Cost effective backup power and large energy recapture
- Low operating costs
- High efficiency (>98%) under broad environmental conditions
- High reliability, green solution
- UL recognized (3000 F)

Applications

- Backup power
- Peak power shaving, pulse power
- Engine starting
- Energy capture and re-use (Hybrids) for automotive, trucks, mining and construction, equipment, cranes
- Remote power for sensors, LEDs, switches

Ratings

Capacitance	3000 F to 3400 F
Maximum working voltage	2.70 V / 2.85 V
Surge voltage	2.85 V / 3.00 V
Capacitance tolerance	0% to +20%
Operating temperature range	-40 °C to +65 °C
Extended operating temperature range	-40 °C to +85 °C (with voltage derating to 2.30 V / 2.45 V @ +85 °C)

Specifications

Capacitance ¹ (F)	Part Number	Maximum working voltage (V)	Maximum initial ESR ¹ (mΩ)	Nominal leakage current ² (mA)	Stored energy ³ (Wh)	Peak power ⁴ (W)	Pulse current ⁵ (A)	Continuous current ⁶ (A)	Typical thermal resistance ⁷ Rth (°C/W)	Short circuit current ⁸ (A)
3000	XL60-2R7308W-R	2.70	0.23	5.0	3.0	7,900	2,400	143	3.2	11,700
3000	XL60-2R7308T-R	2.70	0.23	5.0	3.0	7,900	2,400	143	3.2	11,700
3400	XL60-2R9348W-R	2.85	0.23	8.0	3.8	8,800	2,700	143	3.2	12,400
3400	XL60-2R9348T-R	2.85	0.23	8.0	3.8	8,800	2,700	143	3.2	12,400

Performance

Parameter	Capacitance Change (% of initial value)	ESR (% of initial maximum value)
Lifetime — 1,500 hours at maximum rated voltage and operating temperature	≤ 20%	≤ 200%
Charge/discharge cycling ⁹ — 1 million at +25 °C	≤ 20%	≤ 200%
Storage, uncharged, up to +35 °C — 3 years	≤ 5%	≤ 10%

1. Capacitance, Equivalent Series Resistance (ESR) and Leakage current are measured according to IEC62391-1 with current in milliamps (mA) = $8 \times C \times V$.

2. Leakage current at +20 °C after 72 hour charge and hold.

3. Stored Energy (Wh) = $\frac{0.5 \times C \times V^2}{3600}$

4. Peak Power (W) = $\frac{V^2}{4 \times \text{ESR}}$

5. Pulse current for 1 second from full rate voltage to half voltage. (A) = $\frac{0.5 \times V \times C}{(1 + \text{ESR} \times C)}$

6. Continuous current with a 15 °C temperature rise. Continuous current (A) = $\sqrt{\frac{P}{\text{ESR} \times R_{th}}}$

7. Thermal resistance (Rth) cell body temperature to ambient in open air in degrees C per Watt (°C/W).

8. Short circuit current is for safety information only. Do not use as operating current.

9. Cycling between maximum working voltage and half voltage with 3 seconds rest at +25 °C, 100 A.

Safety and Certifications

Agency information	UL Recognized (3000 F), Guide BBBG2, File MH46887
Shock and vibration	IEC 61373 Category 1, Class B, IEC 60068-2-6
Safety	UL 810A
Environmental	RoHS compliant, lead free, halogen free
Altitude, Operating	10,000 ft
Altitude, Non-operating	40,000 ft

Dimensions (mm)

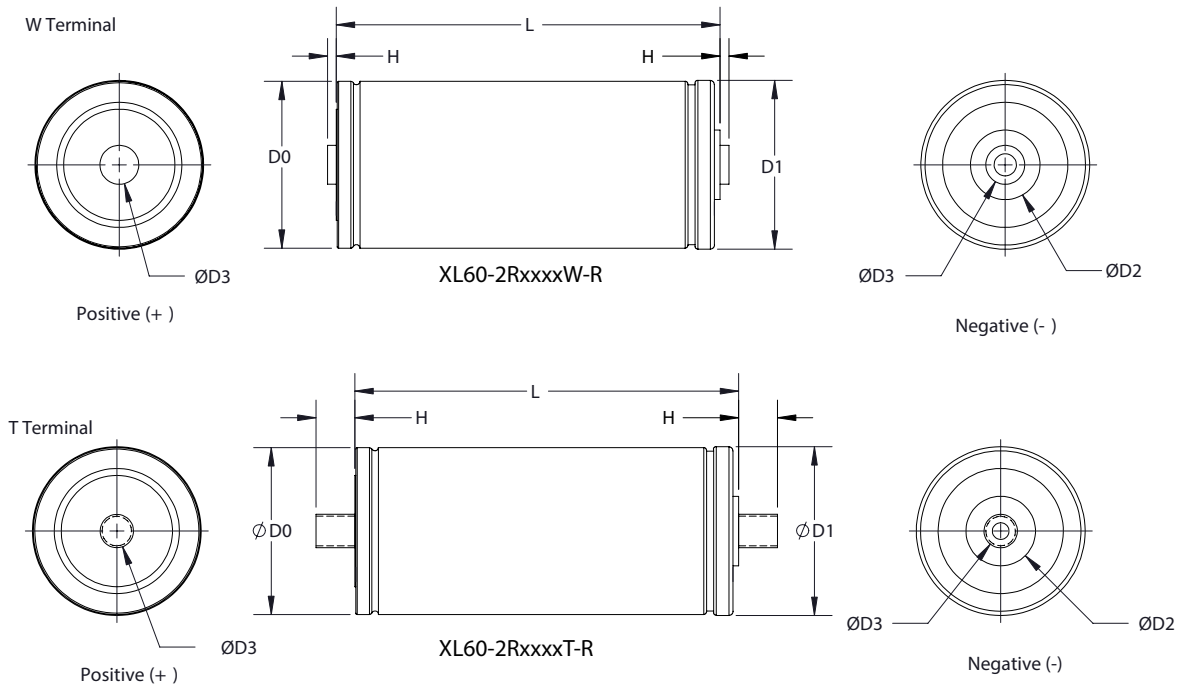

Part Number	D0 (±0.3)	D1 (±0.7)	D2 (±0.1)	D3 (±0.1)	H (±0.125)	L (±0.5)	Typical mass (g)
XL60-2RxxxxW-R	60.3	60.7	25.0	Ø14.0	3.18	138.0	525
XL60-2RxxxxT-R	60.3	60.7	25.0	M12, P1.75	14.0	138.0	515

Part numbering system

XL	60	-2R7	30	8	-R
Family code	Size reference (mm)	Voltage (V) R = decimal	Capacitance (µF) Value	Multiplier	Standard product
XL = Family Code	Diameter = 60	2R7 = 2.7 V	Example 308 = 30 x 10 ⁸ µF or 3,000 F		

Packaging information

- Standard packaging: Bulk, 20 parts per box

Part Marking

- Manufacturer
- Capacitance (F)
- Maximum working voltage (V)
- Family code or part number

Life Support Policy: Eaton does not authorize the use of any of its products for use in life support devices or systems without the express written approval of an officer of the Company. Life support systems are devices which support or sustain life, and whose failure to perform, when properly used in accordance with instructions for use provided in the labeling, can be reasonably expected to result in significant injury to the user.

Eaton reserves the right, without notice, to change design or construction of any products and to discontinue or limit distribution of any products. Eaton also reserves the right to change or update, without notice, any technical information contained in this bulletin

Eaton
Electronics Division
1000 Eaton Boulevard
Cleveland, OH 44122
United States
www.eaton.com/electronics

© 2017 Eaton
All Rights Reserved
Printed in USA
Publication No. 10339 BU-MC17067
November 2017

Компания «Life Electronics» занимается поставками электронных компонентов импортного и отечественного производства от производителей и со складов крупных дистрибьюторов Европы, Америки и Азии.

С конца 2013 года компания активно расширяет линейку поставок компонентов по направлению коаксиальный кабель, кварцевые генераторы и конденсаторы (керамические, пленочные, электролитические), за счёт заключения дистрибьюторских договоров

Мы предлагаем:

- Конкуренеспособные цены и скидки постоянным клиентам.
- Специальные условия для постоянных клиентов.
- Подбор аналогов.
- Поставку компонентов в любых объемах, удовлетворяющих вашим потребностям.
- Приемлемые сроки поставки, возможна ускоренная поставка.
- Доставку товара в любую точку России и стран СНГ.
- Комплексную поставку.
- Работу по проектам и поставку образцов.
- Формирование склада под заказчика.
- Сертификаты соответствия на поставляемую продукцию (по желанию клиента).
- Тестирование поставляемой продукции.
- Поставку компонентов, требующих военную и космическую приемку.
- Входной контроль качества.
- Наличие сертификата ISO.

В составе нашей компании организован Конструкторский отдел, призванный помогать разработчикам, и инженерам.

Конструкторский отдел помогает осуществить:

- Регистрацию проекта у производителя компонентов.
- Техническую поддержку проекта.
- Защиту от снятия компонента с производства.
- Оценку стоимости проекта по компонентам.
- Изготовление тестовой платы монтаж и пусконаладочные работы.



Тел: +7 (812) 336 43 04 (многоканальный)

Email: org@lifeelectronics.ru