

Finisar

Product Specification

WDM SFP Transceiver with APD Receiver

FWLF16197Dxx

PRODUCT FEATURES

- Up to 1.25 Gb/s data links
- Hot-pluggable SFP footprint
- Built-in digital diagnostic functions
- Uncooled DFB laser transmitter in 8 CWDM wavelengths
- APD Receiver
- Very low jitter
- Metal enclosure, for lower EMI
- Single 3.3V power supply
- Operating temperature range: 0°C to 70°C



APPLICATIONS

- Metro Access Rings and Point-to-Point networking for Gigabit Ethernet and Fibre Channel

Finisar's FWLF16197Dxx CWDM Small Form Factor Pluggable (SFP) transceivers are designed for operation in Metro Access Rings and Point-to-Point networks using Gigabit Ethernet and Fibre Channel networking equipment. They are available in eight different CWDM wavelengths. Digital diagnostics functions are available via an I²C serial bus. In addition, they comply with the Small Form Factor Pluggable Multi-Sourcing Agreement (MSA)¹.

PRODUCT SELECTION

FWLF16197Dxx

xx : (See next page)

Wavelength	xx	Clasp Color Code	Wavelength	xx	Clasp Color Code
1471 nm	47	Gray	1551 nm	55	Yellow
1491 nm	49	Violet	1571 nm	57	Orange
1511 nm	51	Blue	1591 nm	59	Red
1531 nm	53	Green	1611 nm	61	Brown

I. Pin Descriptions

Pin	Symbol	Name/Description	Ref.
1	V _{EET}	Transmitter Ground (Common with Receiver Ground)	1
2	T _{FAULT}	Transmitter Fault. Not supported.	
3	T _{DIS}	Transmitter Disable. Laser output disabled on high or open.	2
4	MOD_DEF(2)	Module Definition 2. Data line for Serial ID.	3
5	MOD_DEF(1)	Module Definition 1. Clock line for Serial ID.	3
6	MOD_DEF(0)	Module Definition 0. Grounded within the module.	3
7	Rate Select	No connection required	4
8	LOS	Loss of Signal indication. Logic 0 indicates normal operation.	5
9	V _{EER}	Receiver Ground (Common with Transmitter Ground)	1
10	V _{EER}	Receiver Ground (Common with Transmitter Ground)	1
11	V _{EER}	Receiver Ground (Common with Transmitter Ground)	1
12	RD-	Receiver Inverted DATA out. AC Coupled	
13	RD+	Receiver Non-inverted DATA out. AC Coupled	
14	V _{EER}	Receiver Ground (Common with Transmitter Ground)	1
15	V _{CCR}	Receiver Power Supply	
16	V _{CCT}	Transmitter Power Supply	
17	V _{EET}	Transmitter Ground (Common with Receiver Ground)	1
18	TD+	Transmitter Non-Inverted DATA in. 100 ohm termination between TD+ and TD-, AC Coupled thereafter.	
19	TD-	Transmitter Inverted DATA in. See TD+	
20	V _{EET}	Transmitter Ground (Common with Receiver Ground)	1

Notes:

- Circuit ground is internally isolated from chassis ground.**
- Laser output disabled on T_{DIS} > 2.0V or open, enabled on T_{DIS} < 0.8V.
- Should be pulled up with 4.7k – 10kohms on host board to a voltage between 2.0V and 5.5V. MOD_DEF(0) pulls line low to indicate module is plugged in.
- Finisar 2x receiver achieves simultaneous 1x and 2x operation without active control.
- LOS is open collector output. Should be pulled up with 4.7k – 10kohms on host board to a voltage between 2.0V and 5.5V. Logic 0 indicates normal operation; logic 1 indicates loss of signal.

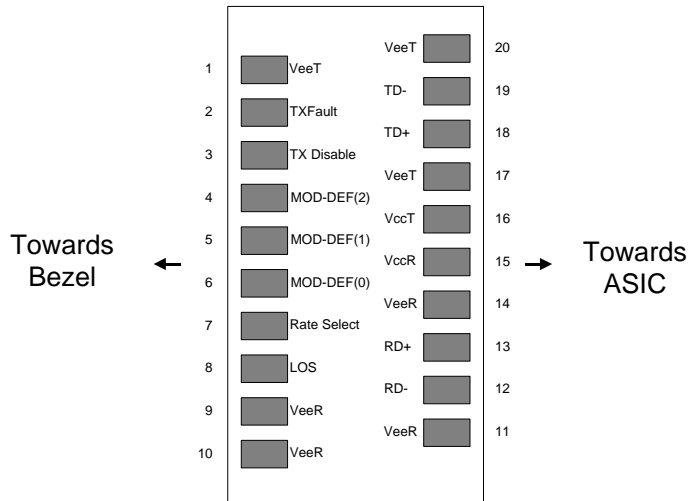

Diagram of Host Board Connector Block Pin Numbers and Names

II. Absolute Maximum Ratings

Parameter	Symbol	Min	Typ	Max	Unit	Ref.
Maximum Supply Voltage	V _{CC}	-0.5		4.7	V	
Storage Temperature	T _S	-40		85	°C	
Case Operating Temperature	T _{OP}	0		70	°C	

III. Electrical Characteristics (T_{OP} = 0 to 70 °C, V_{CC} = 3.15 to 3.60 Volts)

Parameter	Symbol	Min	Typ	Max	Unit	Ref.
Supply Voltage	V _{CC}	3.15		3.60	V	
Supply Current	I _{CC}		200	300	mA	
Transmitter						
Input differential impedance	R _{in}		100		Ω	1
Single ended data input swing	V _{in,pp}	250		1200	mV	
Transmit Disable Voltage	V _D	V _{CC} - 1.3		V _{CC}	V	
Transmit Enable Voltage	V _{EN}	V _{EE}		V _{EE} + 0.8	V	2
Transmit Disable Assert Time				10	us	
Receiver						
Single ended data output swing	V _{out,pp}	250		800	mV	3
Data output rise time	t _r		100	260	ps	4
Data output fall time	t _f		100	260	ps	4
LOS Fault	V _{LOS fault}	V _{CC} - 0.5		V _{CC,HOST}	V	5
LOS Normal	V _{LOS norm}	V _{EE}		V _{EE} +0.5	V	5
Power Supply Rejection	PSR	100			mVpp	6

Notes:

1. Connected directly to TX data input pins. AC coupled thereafter.
2. Or open circuit.

3. Into 100 ohms differential termination.
4. 20 – 80 %
5. Loss Of Signal is LVTTL. Logic 0 indicates normal operation; logic 1 indicates no signal detected.
6. Receiver sensitivity is compliant with power supply sinusoidal modulation of 20 Hz to 1.5 MHz up to specified value applied through the recommended power supply filtering network.

IV. Optical Characteristics ($T_{OP} = 0$ to 70 °C, $V_{CC} = 3.15$ to 3.60 Volts)

Parameter	Symbol	Min	Typ	Max	Unit	Ref.
Transmitter						
Output Opt. Pwr (End of Life)	P_{OUT}	+0		+5	dBm	1
Optical Wavelength	λ	(x-6.5)	(x)	(x+6.5)	nm	
Wavelength Temperature Dependence			0.08	0.125	nm/°C	
Spectral Width (-20dB)	σ			1	nm	
Optical Extinction Ratio	ER	9			dB	
Sidemode Suppression ratio	SSR_{min}	30			dB	
Optical Rise/Fall Time	t_r / t_f			180	ps	2
RIN	RIN			-120	dB/Hz	
Transmitter Jitter (peak to peak)				100	ps	
Receiver						
Average Rx Sensitivity	R_{SENS2}			-29	dBm	3
Maximum Input Power	P_{MAX}	-7			dBm	
Optical Center Wavelength	λ_C	1270		1620	nm	
LOS De-Assert	LOS_D			-32	dBm	
LOS Assert	LOS_A	-42			dBm	
LOS Hysteresis			1.0		dB	
Receiver Jitter Generation (peak to peak)				160	ps	4
Dispersion Penalty at 100km				2.5	dB	3,5

Notes:

1. Over case temperature of 0 to 70 °C. The Transmitter Center Wavelength “x” is as specified by the customer. The current available wavelengths are: 1471, 1491, 1511, 1531, 1551, 1571, 1591, and 1611 nm. Please see the “Product Selection” section on page 1.
2. Unfiltered
3. Worst-case extinction ratio. Measured with a PRBS 2^7-1 test pattern, @1.25Gb/s, BER< 10^{-12} , EOL
4. Jitter added by receiver (peak to peak). Measured at -29dBm average Rx sensitivity, PRBS 2^7-1 test pattern.
5. Measured using 9/125 μ m SMF-28.

V. General Specifications

Parameter	Symbol	Min	Typ	Max	Units	Ref.
Data Rate	BR	0.622		1.25	Gb/sec	
Total System Budget	--	29	30		dB	@1.25 Gb/s, BER < 10 ⁻¹² w/ PRBS 2 ⁷ -1.

VI. Environmental Specifications

Finisar CWDM SFP transceivers have an operating temperature range from 0°C to +70°C case temperature.

Parameter	Symbol	Min	Typ	Max	Units	Ref.
Case Operating Temperature	T _{op}	0		70	°C	
Storage Temperature	T _{sto}	-40		85	°C	

VII. Regulatory Compliance

Finisar CWDM SFP transceivers are Class 1 Laser Products. They are certified per the following standards:

Feature	Agency	Standard
Laser Eye Safety	FDA/CDRH	CDRH and IEC-825 Class 1 Laser Product. See Note 1
Laser Eye Safety	TÜV	EN 60950 EN 60825-1 EN 60825-2
Electrical Safety	CSA	CLASS 3862.07 CLASS 3862.87

Note 1: Complies with FDA performance standards for laser products except for deviations pursuant to Laser Notice No. 50, dated July 26, 2001.

VIII. Digital Diagnostic Functions

Finisar FWLF16197Dxx SFP transceivers support the 2-wire serial communication protocol as defined in the draft SFP MSA¹. It is very closely related to the E²PROM defined in the GBIC standard, with the same electrical specifications.

The standard SFP serial ID provides access to identification information that describes the transceiver's capabilities, standard interfaces, manufacturer, and other information.

Additionally, Finisar SFP transceivers provide a unique enhanced digital diagnostic monitoring interface, which allows real-time access to device operating parameters such as transceiver temperature, laser bias current, transmitted optical power, received optical power and transceiver supply voltage. It also defines a sophisticated system of alarm and warning flags, which alerts end-users when particular operating parameters are outside of a factory set normal range.

The SFP MSA defines a 256-byte memory map in E²PROM that is accessible over a 2-wire serial interface at the 8 bit address 1010000X (A0h). The digital diagnostic monitoring interface makes use of the 8 bit address 1010001X (A2h), so the originally defined serial ID memory map remains unchanged. The interface is identical to, and is thus fully backward compatible with both the GBIC Specification and the SFP Multi Source Agreement. The complete interface is described in Finisar Application Note AN-2030: "Digital Diagnostics Monitoring Interface for SFP Optical Transceivers".

IX. Mechanical Specifications

Finisar's Multi-rate CWDM Small Form Factor Pluggable (SFP) transceivers are compatible with the dimensions defined by the SFP Multi-Sourcing Agreement (MSA).

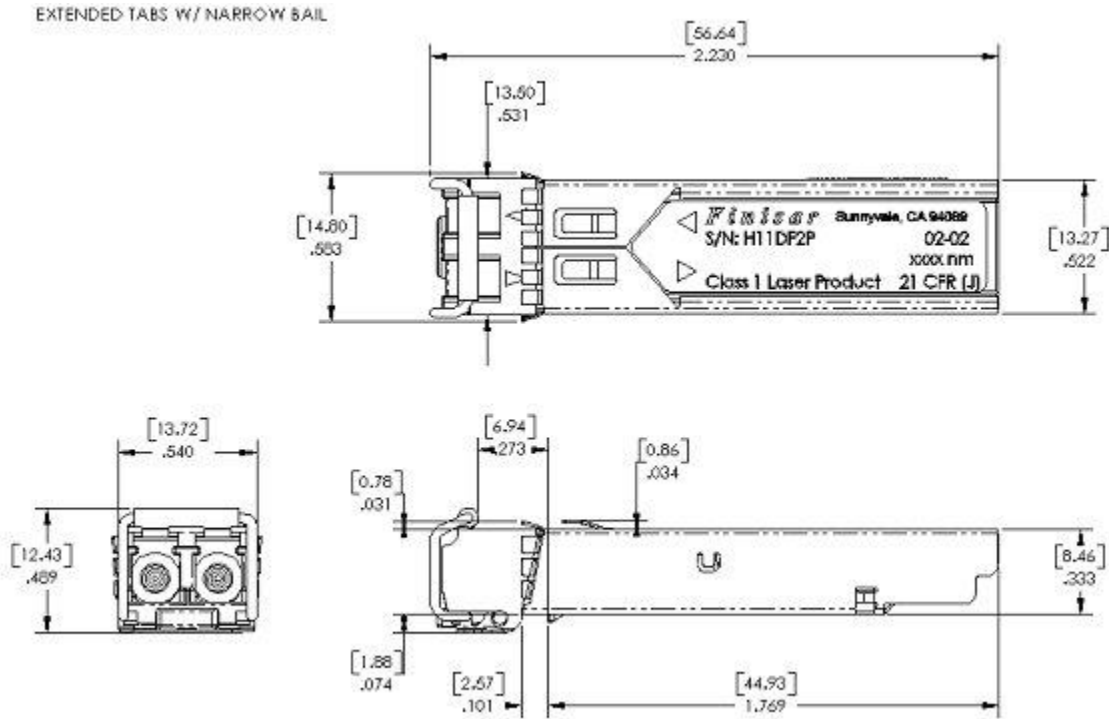

FWLF16197Dxx (dimensions are in inches)

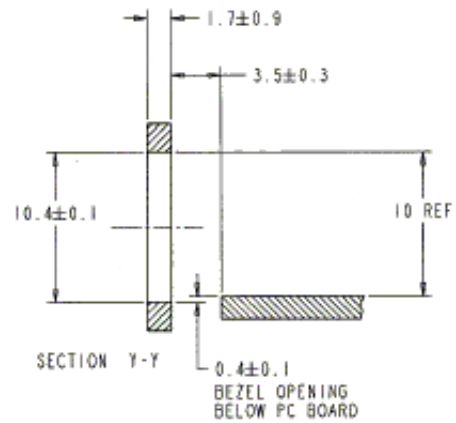
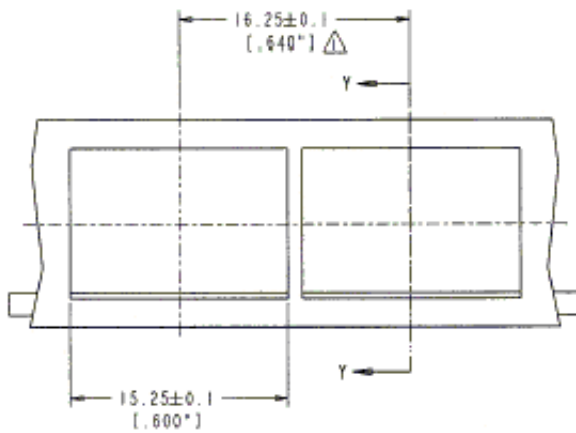
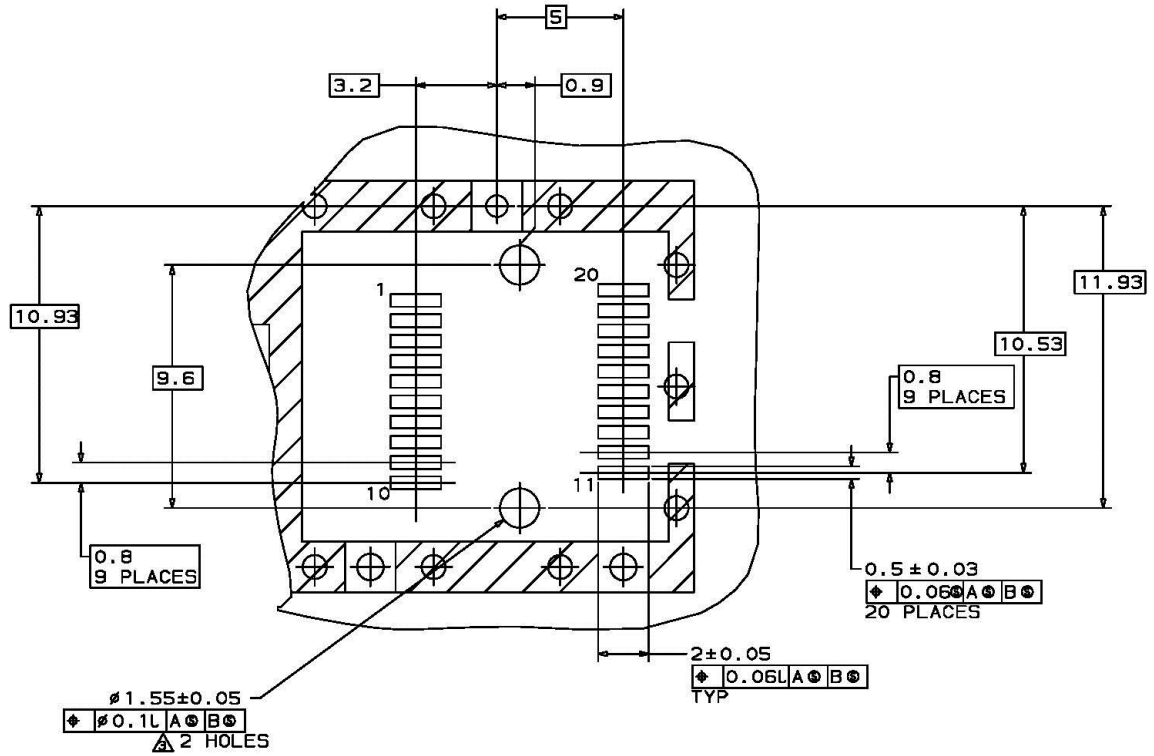

NOTES:

- 1. MINIMUM PITCH ILLUSTRATED, ENGLISH DIMENSIONS ARE FOR REFERENCE ONLY
- 2. NOT RECOMMENDED FOR PCI EXPANSION CARD APPLICATIONS

XI. References

1. Small Form Factor Pluggable (SFP) Transceiver Multi-Source Agreement (MSA), September 2000. Documentation is currently available at Finisar upon request.
2. IEEE Std 802.3. IEEE Standards Department, 2000.^(*)
3. “Fibre Channel Draft Physical Interface Specification (FC-PI 10.0)”. American National Standard for Information Systems.^(*)

(*) Neither IEEE 802.3 nor FC-PI 10.0 specifies a 16xx nm DFB single mode interface. The FWL16197Dxx complies with these specifications except for the following optical parameters, which have different values: transmitter wavelength, receiver sensitivity, and transmit output power. See Section IV for details.

XII. For More Information

Finisar Corporation
1308 Moffett Park Drive
Sunnyvale, CA 94089-1133
Tel. 1-408-548-1000
Fax 1-408-541-6138
sales@finisar.com
www.finisar.com

Компания «Life Electronics» занимается поставками электронных компонентов импортного и отечественного производства от производителей и со складов крупных дистрибьюторов Европы, Америки и Азии.

С конца 2013 года компания активно расширяет линейку поставок компонентов по направлению коаксиальный кабель, кварцевые генераторы и конденсаторы (керамические, пленочные, электролитические), за счёт заключения дистрибьюторских договоров

Мы предлагаем:

- Конкурентоспособные цены и скидки постоянным клиентам.
- Специальные условия для постоянных клиентов.
- Подбор аналогов.
- Поставку компонентов в любых объемах, удовлетворяющих вашим потребностям.
- Приемлемые сроки поставки, возможна ускоренная поставка.
- Доставку товара в любую точку России и стран СНГ.
- Комплексную поставку.
- Работу по проектам и поставку образцов.
- Формирование склада под заказчика.
- Сертификаты соответствия на поставляемую продукцию (по желанию клиента).
- Тестирование поставляемой продукции.
- Поставку компонентов, требующих военную и космическую приемку.
- Входной контроль качества.
- Наличие сертификата ISO.

В составе нашей компании организован Конструкторский отдел, призванный помогать разработчикам, и инженерам.

Конструкторский отдел помогает осуществить:

- Регистрацию проекта у производителя компонентов.
- Техническую поддержку проекта.
- Защиту от снятия компонента с производства.
- Оценку стоимости проекта по компонентам.
- Изготовление тестовой платы монтаж и пусконаладочные работы.



Тел: +7 (812) 336 43 04 (многоканальный)

Email: org@lifeelectronics.ru