

PART NUMBER
(LAST DIGIT INDICATING
PACKAGING TYPE. NOT
PRINTED ON THE PART)

DATE CODE

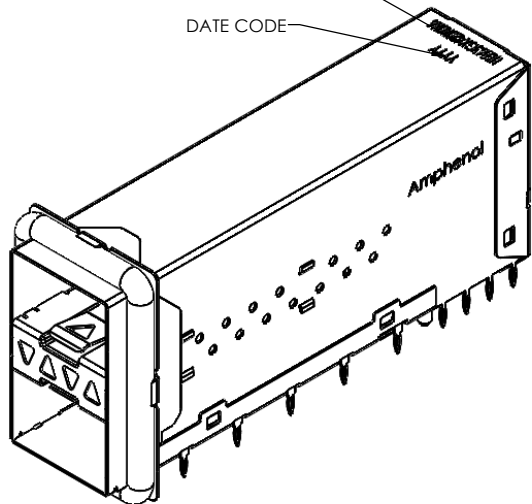

MATERIAL: (RoHS COMPLIANT)

CAGE - PRESS FIT:
COPPER ALLOY (NICKEL SILVER)

CONNECTOR - PRESS FIT:
PLASTIC HOUSING:
LCP, FLAMMABILITY RATING UL94-V0.
CONTACTS:
PHOSPHOR BRONZE
PLATING OPTION:
0.76µm" Gold plating on Mating Area
3.05-7.62µm"Matte Tin on Termination

LIGHT PIPE:
CLEAR POLYCARBONATE, FLAMMABILITY
RATING UL94-V0.

PACKAGING:
TRAY PACKAGING.
TEMPERATURE RANGE:
-40°C TO +85°C

EMI GASKET: CONDUCTIVE ELASTOMER UL94-V0

AMPHENOL PART NUMBER: P-UE86-3G-4420-60361

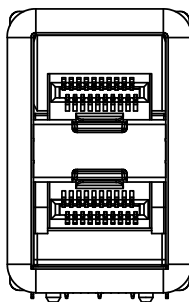

NO LIGHT PIPE
UE86-3G1420-00361

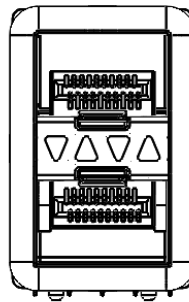

4 LIGHT PIPES
UE86-3G1420-10361

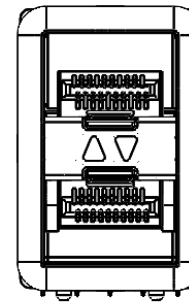

2 INNER LIGHT PIPES
UE86-3G1420-20361

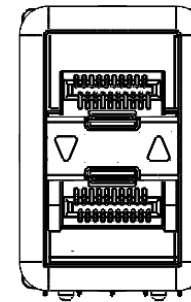

2 OUTER LIGHT PIPES
UE86-3G1420-30361

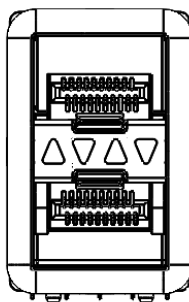

4 LIGHT PIPES UPSIDE DOWN
UE86-3G1420-40361

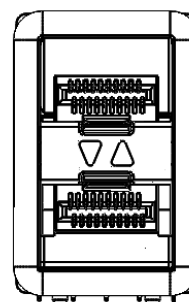

2 INNER LIGHT PIPES UPSIDE DOWN
UE86-3G1420-50361

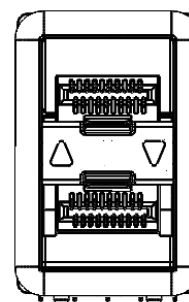

2 OUTER LIGHT PIPES UPSIDE DOWN
UE86-3G1420-60361

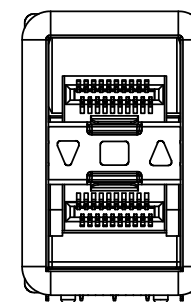

3 LIGHT PIPES
UE86-3G1420-70361

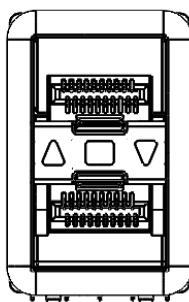

3 LIGHT PIPES UPSIDE DOWN
UE86-3G1420-80361

REVISIONS			
REV	DESCRIPTION, ECN, EAR NO.	DATE	APP'D
B	CORRECTION OF P/NS AND 3rd CONFIGURATION VIEW	NOV 07/13	J. SI

PART NUMBER	DESCRIPTION
UE86-3G1420-00361	NO LIGHT PIPE
UE86-3G1420-10361	4 LIGHT PIPES
UE86-3G1420-20361	2 INNER LIGHT PIPES
UE86-3G1420-30361	2 OUTER LIGHT PIPES
UE86-3G1420-40361	4 LIGHT PIPES UPSIDE DOWN
UE86-3G1420-50361	2 INNER LIGHT PIPES UPSIDE DOWN
UE86-3G1420-60361	2 OUTER LIGHT PIPES UPSIDE DOWN
UE86-3G1420-70361	3 LIGHT PIPES
UE86-3G1420-80361	3 LIGHT PIPES UPSIDE DOWN

UNLESS SPECIFIED OTHERWISE	DRAWN	P. OU	NOV 05/13
PRIMARY UNITS INCHES	CHECKED	J. SI	NOV 06/13
SECONDARY MILLIMETERS	M.E. APP'D		
REFERENCE IN PARENTHESES	Q.A. APP'D		
GENERAL TOLERANCES	DWG APP'D		
1 DECIMAL PLACE ±0.X	ENG. REL. NO.		
2 DECIMAL PLACES ±0.XX	REF.		
3 DECIMAL PLACES ±0.XXX	THIRD ANGLE PROJECTION		
ANGULAR DEGREES ±1°	DO NOT SCALE DRAWING		

Amphenol High Speed Interconnects
A Division of Amphenol Corp. www.amphenolcanada.com

**2X1 SFP ULTRAPORT WITH LIGHT PIPE
OPTIONS AND EMI GASKET VERSION**

DWG. NO.	P-UE86-3G1420-X0361	REV	B
CODE ID NO.	03554	DWG SIZE:	C
SCALE:	2.5:1	SHEET 1 OF 4	

REVISIONS			
REV	DESCRIPTION, ECN, EAR NO.	DATE	APPD
B	CORRECTION OF P/INs AND 3rd CONFIGURATION VIEW	NOV 07/13	J. SI

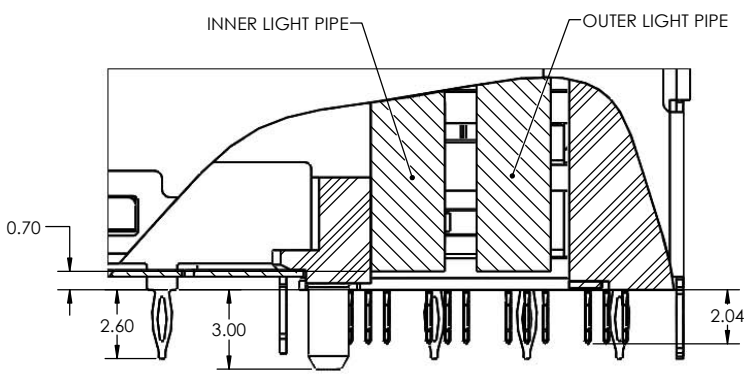
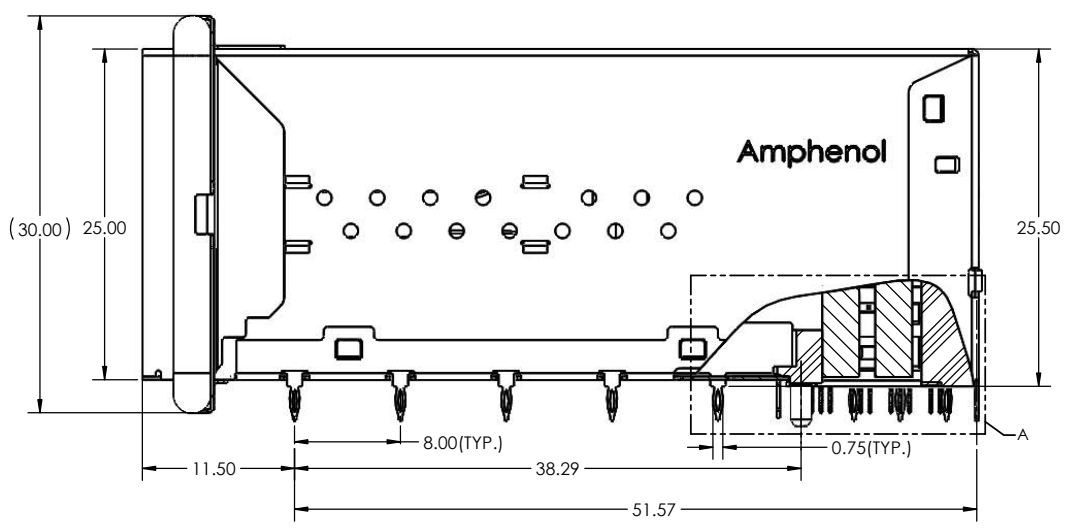
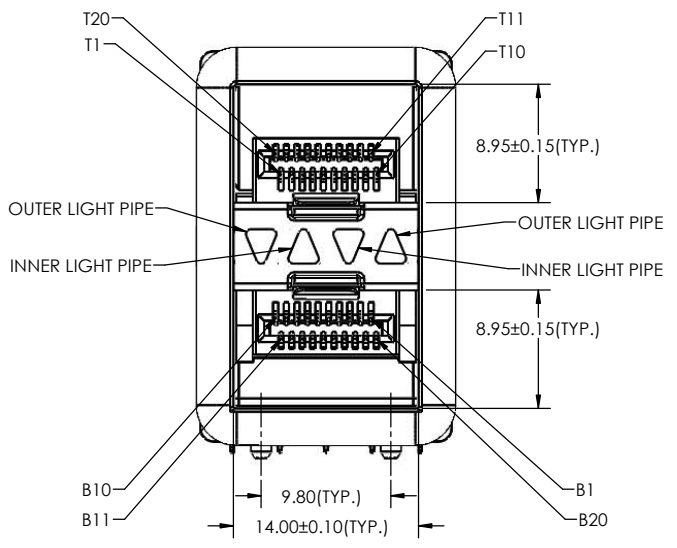

DETAIL A
SCALE 7 : 1

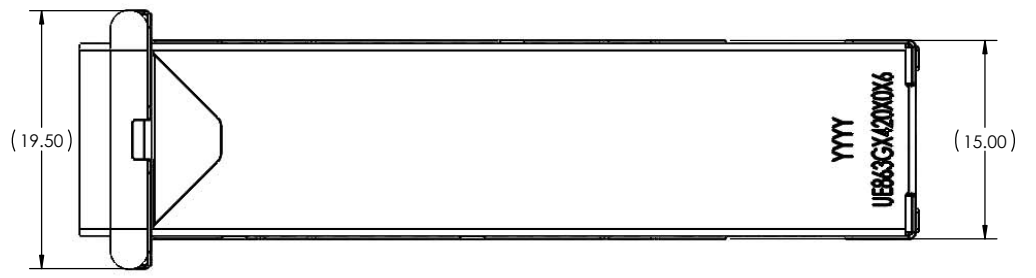

UNLESS SPECIFIED OTHERWISE	DRAWN	P. OU	NOV 05/13
PRIMARY UNITS INCHES	CHECKED	J. SI	NOV 06/13
SECONDARY MILLIMETERS	M.E. APPD		
REFERENCE IN PARENTHESES	Q.A. APPD		
GENERAL TOLERANCES	DWG APPD		
1 DECIMAL PLACE $\pm 0.X$	ENG. REL. NO.		
2 DECIMAL PLACES $\pm 0.XX$	REF.		
3 DECIMAL PLACES $\pm 0.XXX$	THIRD ANGLE PROJECTION		
ANGULAR DEGREES $\pm 1^\circ$	DO NOT SCALE DRAWING		

Amphenol High Speed Interconnects
A Division of Amphenol Corp. www.amphenol-highspeed.com

2X1 SFP ULTRAPORT WITH LIGHT PIPE OPTIONS AND EMI GASKET VERSION

DWG. NO. **P-UE86-3G1420-X0361** REV **B**

CODE ID NO. 03554 DWG SIZE: C SCALE: 2.5:1 SHEET 2 OF 4

THIS DOCUMENT CONTAINS PROPRIETARY INFORMATION AND SUCH INFORMATION MAY NOT BE DISCLOSED TO OTHERS FOR ANY PURPOSE OR USED FOR MANUFACTURING PURPOSES WITHOUT WRITTEN PERMISSION FROM AMPHENOL CANADA CORP.

REVISIONS			
REV	DESCRIPTION, ECN, EAR NO.	DATE	APPD
B	CORRECTION OF P/Ns AND 3rd CONFIGURATION VIEW	NOV 07/13	J. SI

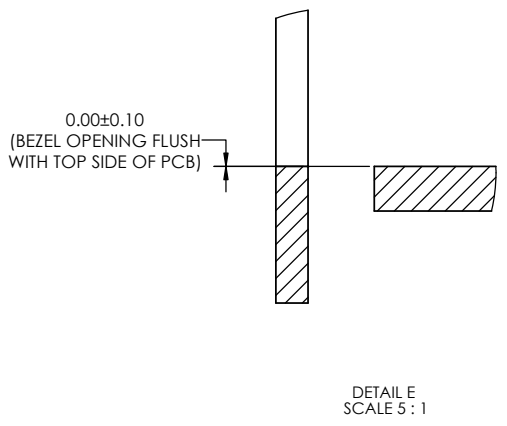
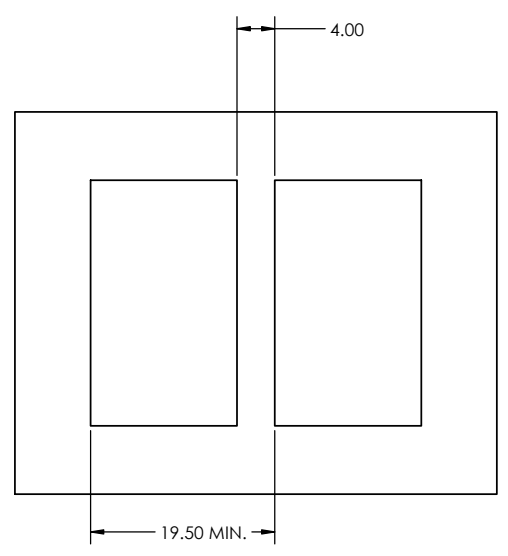
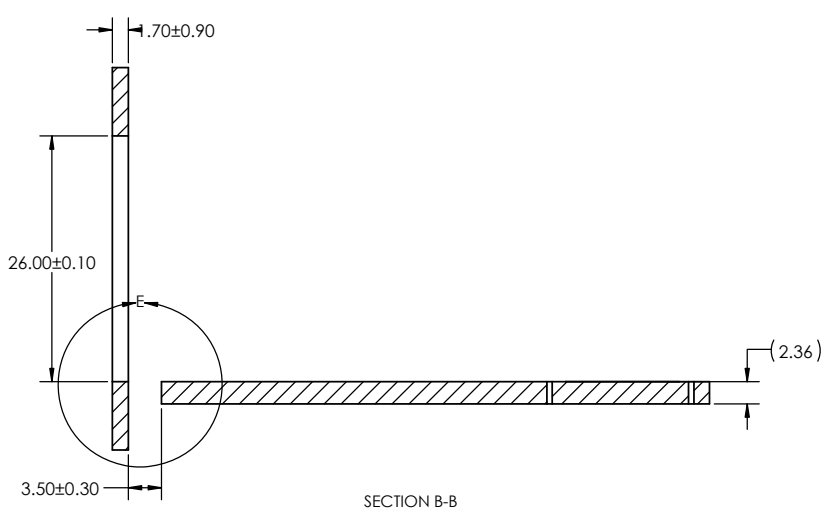
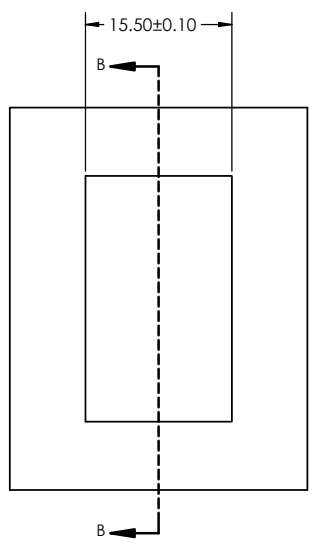

UNLESS SPECIFIED OTHERWISE	DRAWN	P. OU	NOV 05/13
PRIMARY UNITS INCHES	CHECKED	J. SI	NOV 06/13
SECONDARY MILLIMETERS	M.E. APPD		
REFERENCE IN PARENTHESES	Q.A. APPD		
GENERAL TOLERANCES	DWG APPD		
1 DECIMAL PLACE ±0.X	ENG. REL. NO.		
2 DECIMAL PLACES ±0.XX	REF.		
3 DECIMAL PLACES ±0.XXX	THIRD ANGLE PROJECTION		
ANGULAR DEGREES ±1°	DO NOT SCALE DRAWING		

Amphenol High Speed Interconnects A Division of Amphenol Corp. www.amphenol-highspeed.com			
2X1 SFP ULTRAPORT WITH LIGHT PIPE OPTIONS AND EMI GASKET VERSION			
DWG. NO.	P-UE86-3G1420-X0361		REV B
CODE ID NO.	03554	DWG SIZE: C	SCALE: 2.5:1 SHEET 3 OF 4

THIS DOCUMENT CONTAINS PROPRIETARY INFORMATION AND SUCH INFORMATION MAY NOT BE DISCLOSED TO OTHERS FOR ANY PURPOSE OR USED FOR MANUFACTURING PURPOSES WITHOUT WRITTEN PERMISSION FROM AMPHENOL CANADA CORP.

REVISIONS			
REV	DESCRIPTION, ECN, EAR NO.	DATE	APP'D
B	CORRECTION OF P/NS AND 3rd CONFIGURATION VIEW	NOV 07/13	J. SI

NOTES:
1. 0.56MM DIAMETER HOLES ARE CHASSIS GROUND (24 HOLES)

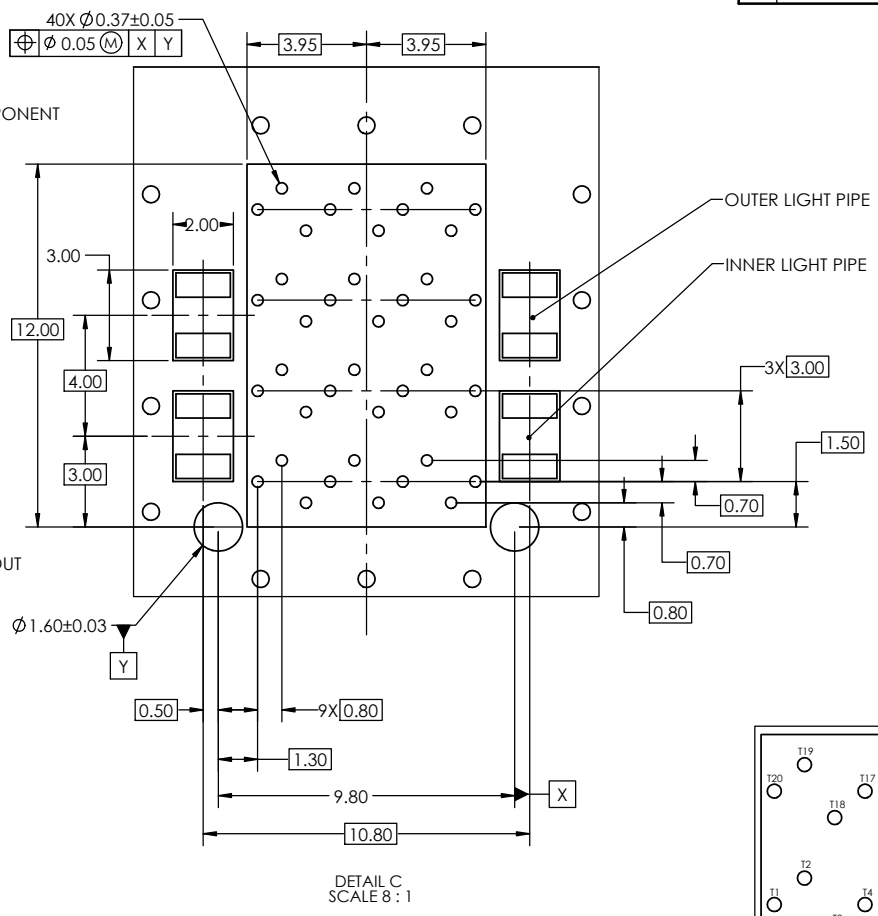
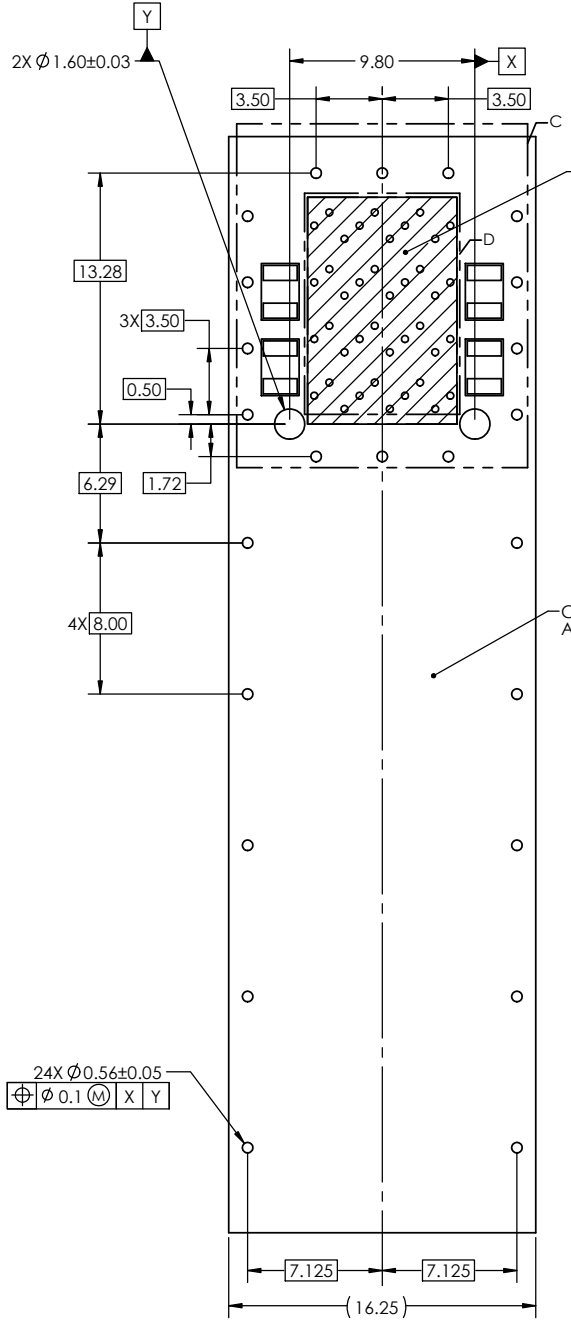

DETAIL C SCALE 8 : 1

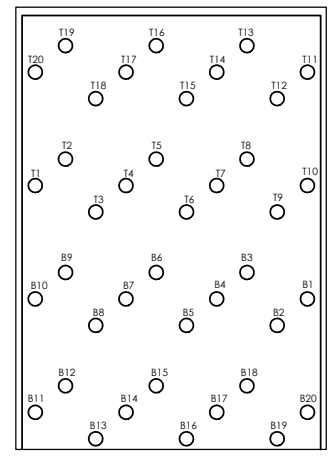

DETAIL D SCALE 10 : 1

24X Ø 0.56±0.05
Ø 0.1 M X Y



UNLESS SPECIFIED OTHERWISE	DRAWN	P. OU	NOV 05/13
PRIMARY UNITS INCHES	CHECKED	J. SI	NOV 06/13
SECONDARY MILLIMETERS	M.E. APP'D		
REFERENCE IN PARENTHESES	Q.A. APP'D		
GENERAL TOLERANCES	DWG APP'D		
1 DECIMAL PLACE ±0.X	ENG. REL. NO.		
2 DECIMAL PLACES ±0.XX	REF.		
3 DECIMAL PLACES ±0.XXX	THIRD ANGLE PROJECTION		
ANGULAR DEGREES ±1°	DO NOT SCALE DRAWING		

Amphenol High Speed Interconnects
A Division of Amphenol Corp. www.amphenol-highspeed.com

2X1 SFP ULTRAPORT WITH LIGHT PIPE OPTIONS AND EMI GASKET VERSION

DWG. NO. **P-UE86-3G1420-X0361** REV **B**

CODE ID NO. 03554 DWG SIZE: C SCALE: 2.5:1 SHEET 4 OF 4

THIS DOCUMENT CONTAINS PROPRIETARY INFORMATION AND SUCH INFORMATION MAY NOT BE DISCLOSED TO OTHERS FOR ANY PURPOSE OR USED FOR MANUFACTURING PURPOSES WITHOUT WRITTEN PERMISSION FROM AMPHENOL CANADA CORP.

Компания «Life Electronics» занимается поставками электронных компонентов импортного и отечественного производства от производителей и со складов крупных дистрибьюторов Европы, Америки и Азии.

С конца 2013 года компания активно расширяет линейку поставок компонентов по направлению коаксиальный кабель, кварцевые генераторы и конденсаторы (керамические, пленочные, электролитические), за счёт заключения дистрибьюторских договоров

Мы предлагаем:

- Конкурентоспособные цены и скидки постоянным клиентам.
- Специальные условия для постоянных клиентов.
- Подбор аналогов.
- Поставку компонентов в любых объемах, удовлетворяющих вашим потребностям.
- Приемлемые сроки поставки, возможна ускоренная поставка.
- Доставку товара в любую точку России и стран СНГ.
- Комплексную поставку.
- Работу по проектам и поставку образцов.
- Формирование склада под заказчика.
- Сертификаты соответствия на поставляемую продукцию (по желанию клиента).
- Тестирование поставляемой продукции.
- Поставку компонентов, требующих военную и космическую приемку.
- Входной контроль качества.
- Наличие сертификата ISO.

В составе нашей компании организован Конструкторский отдел, призванный помогать разработчикам, и инженерам.

Конструкторский отдел помогает осуществить:

- Регистрацию проекта у производителя компонентов.
- Техническую поддержку проекта.
- Защиту от снятия компонента с производства.
- Оценку стоимости проекта по компонентам.
- Изготовление тестовой платы монтаж и пусконаладочные работы.



Тел: +7 (812) 336 43 04 (многоканальный)
Email: org@lifeelectronics.ru