



**MCP661**  
**Line Driver**  
**Demo Board**  
**User's Guide**

---

**Note the following details of the code protection feature on Microchip devices:**

- Microchip products meet the specification contained in their particular Microchip Data Sheet.
- Microchip believes that its family of products is one of the most secure families of its kind on the market today, when used in the intended manner and under normal conditions.
- There are dishonest and possibly illegal methods used to breach the code protection feature. All of these methods, to our knowledge, require using the Microchip products in a manner outside the operating specifications contained in Microchip's Data Sheets. Most likely, the person doing so is engaged in theft of intellectual property.
- Microchip is willing to work with the customer who is concerned about the integrity of their code.
- Neither Microchip nor any other semiconductor manufacturer can guarantee the security of their code. Code protection does not mean that we are guaranteeing the product as "unbreakable."

Code protection is constantly evolving. We at Microchip are committed to continuously improving the code protection features of our products. Attempts to break Microchip's code protection feature may be a violation of the Digital Millennium Copyright Act. If such acts allow unauthorized access to your software or other copyrighted work, you may have a right to sue for relief under that Act.

---

Information contained in this publication regarding device applications and the like is provided only for your convenience and may be superseded by updates. It is your responsibility to ensure that your application meets with your specifications. MICROCHIP MAKES NO REPRESENTATIONS OR WARRANTIES OF ANY KIND WHETHER EXPRESS OR IMPLIED, WRITTEN OR ORAL, STATUTORY OR OTHERWISE, RELATED TO THE INFORMATION, INCLUDING BUT NOT LIMITED TO ITS CONDITION, QUALITY, PERFORMANCE, MERCHANTABILITY OR FITNESS FOR PURPOSE. Microchip disclaims all liability arising from this information and its use. Use of Microchip devices in life support and/or safety applications is entirely at the buyer's risk, and the buyer agrees to defend, indemnify and hold harmless Microchip from any and all damages, claims, suits, or expenses resulting from such use. No licenses are conveyed, implicitly or otherwise, under any Microchip intellectual property rights.

**Trademarks**

The Microchip name and logo, the Microchip logo, dsPIC, KEELOQ, KEELOQ logo, MPLAB, PIC, PICmicro, PICSTART, rfPIC and UNI/O are registered trademarks of Microchip Technology Incorporated in the U.S.A. and other countries.

FilterLab, Hampshire, HI-TECH C, Linear Active Thermistor, MXDEV, MXLAB, SEEVAL and The Embedded Control Solutions Company are registered trademarks of Microchip Technology Incorporated in the U.S.A.

Analog-for-the-Digital Age, Application Maestro, CodeGuard, dsPICDEM, dsPICDEM.net, dsPICworks, dsSPEAK, ECAN, ECONOMONITOR, FanSense, HI-TIDE, In-Circuit Serial Programming, ICSP, ICEPIC, Mindi, MiWi, MPASM, MPLAB Certified logo, MPLIB, MPLINK, mTouch, Omniscent Code Generation, PICC, PICC-18, PICKit, PICDEM, PICDEM.net, PICTail, PIC<sup>32</sup> logo, REAL ICE, rLAB, Select Mode, Total Endurance, TSHARC, WiperLock and ZENA are trademarks of Microchip Technology Incorporated in the U.S.A. and other countries.

SQTP is a service mark of Microchip Technology Incorporated in the U.S.A.

All other trademarks mentioned herein are property of their respective companies.

© 2009, Microchip Technology Incorporated, Printed in the U.S.A., All Rights Reserved.

 Printed on recycled paper.

**QUALITY MANAGEMENT SYSTEM**  
**CERTIFIED BY DNV**  
**== ISO/TS 16949:2002 ==**

*Microchip received ISO/TS-16949:2002 certification for its worldwide headquarters, design and wafer fabrication facilities in Chandler and Tempe, Arizona; Gresham, Oregon and design centers in California and India. The Company's quality system processes and procedures are for its PIC<sup>®</sup> MCUs and dsPIC<sup>®</sup> DSCs, KEELOQ<sup>®</sup> code hopping devices, Serial EEPROMs, microperipherals, nonvolatile memory and analog products. In addition, Microchip's quality system for the design and manufacture of development systems is ISO 9001:2000 certified.*



# MCP661 LINE DRIVER DEMO BOARD USER'S GUIDE

---

---

## Table of Contents

---

---

<b>Preface</b> .....	<b>1</b>
Introduction.....	1
Document Layout .....	1
Conventions Used in this Guide .....	2
Recommended Reading.....	3
The Microchip Web Site .....	3
Customer Support .....	3
Document Revision History .....	3
<b>Chapter 1. Product Overview</b>	
1.1 Introduction .....	5
1.2 Kit Contents .....	5
1.3 Intended Use .....	6
1.4 Description .....	6
<b>Chapter 2. Installation and Operation</b>	
2.1 Introduction .....	9
2.2 Required Tools .....	9
2.3 Configuring the Lab Equipment and PCB .....	10
<b>Appendix A. Schematics and Layouts</b>	
A.1 Introduction .....	11
A.2 Board – Schematic .....	12
A.3 Board – Top Silk Screen, Top Solder Mask and Top Metal .....	13
A.4 Board – Top Silk Screen and Top Solder Mask .....	13
A.5 Board – Bottom Metal Layer (Top View) .....	14
A.6 Board – Bottom Metal Layer (Bottom View) .....	14
<b>Appendix B. Bill Of Materials (BOM)</b>	
B.1 MCP661 Line Driver Demo Board BOM .....	15
<b>Worldwide Sales and Service</b> .....	<b>16</b>

# MCP661 Line Driver Demo Board User's Guide

---

NOTES:



# MCP661 LINE DRIVER DEMO BOARD USER'S GUIDE

---

---

## Preface

---

---

### NOTICE TO CUSTOMERS

All documentation becomes dated, and this manual is no exception. Microchip tools and documentation are constantly evolving to meet customer needs, so some actual dialogs and/or tool descriptions may differ from those in this document. Please refer to our web site ([www.microchip.com](http://www.microchip.com)) to obtain the latest documentation available.

Documents are identified with a "DS" number. This number is located on the bottom of each page, in front of the page number. The numbering convention for the DS number is "DSXXXXA", where "XXXX" is the document number and "A" is the revision level of the document.

For the most up-to-date information on development tools, see the MPLAB® IDE on-line help. Select the Help menu, and then Topics to open a list of available on-line help files.

## INTRODUCTION

This chapter contains general information that will be useful to know before using the MCP661 Line Driver Demo Board. Items discussed in this chapter include:

- Document Layout
- Conventions Used in this Guide
- Recommended Reading
- The Microchip Web Site
- Customer Support
- Document Revision History

## DOCUMENT LAYOUT

This document describes how to use the MCP661 Line Driver Demo Board. The manual layout is as follows:

- **Chapter 1. "Product Overview"** - Important information about the MCP661 Line Driver Demo Board.
- **Chapter 2. "Installation and Operation"** – Covers the initial set-up of the MCP661 Line Driver Demo Board. It lists the required tools, shows how to set up the board and how to connect lab equipment. It then demonstrates how to use this board.
- **Appendix A. "Schematics and Layouts"** – Shows the schematic and board layouts for the MCP661 Line Driver Demo Board.
- **Appendix B. "Bill Of Materials (BOM)"** – Lists the parts used to populate the MCP661 Line Driver Demo Board. Also lists alternate components.

# MCP661 Line Driver Demo Board User's Guide

## CONVENTIONS USED IN THIS GUIDE

This manual uses the following documentation conventions:

### DOCUMENTATION CONVENTIONS

Description	Represents	Examples
<b>Arial font:</b>		
Italic characters	Referenced books	<i>MPLAB<sup>®</sup> IDE User's Guide</i>
	Emphasized text	...is the <i>only</i> compiler...
Initial caps	A window	the Output window
	A dialog	the Settings dialog
	A menu selection	select Enable Programmer
Quotes	A field name in a window or dialog	"Save project before build"
Underlined, italic text with right angle bracket	A menu path	<u><i>File&gt;Save</i></u>
Bold characters	A dialog button	Click <b>OK</b>
	A tab	Click the <b>Power</b> tab
N'Rnnnn	A number in verilog format, where N is the total number of digits, R is the radix and n is a digit.	4'b0010, 2'hF1
Text in angle brackets < >	A key on the keyboard	Press <Enter>, <F1>
<b>Courier New font:</b>		
Plain Courier New	Sample source code	#define START
	Filenames	autoexec.bat
	File paths	c:\mcc18\h
	Keywords	_asm, _endasm, static
	Command-line options	-Opa+, -Opa-
	Bit values	0, 1
	Constants	0xFF, 'A'
Italic Courier New	A variable argument	<i>file.o</i> , where <i>file</i> can be any valid filename
Square brackets [ ]	Optional arguments	mcc18 [options] <i>file</i> [options]
Curly brackets and pipe character: {   }	Choice of mutually exclusive arguments; an OR selection	errorlevel {0 1}
Ellipses...	Replaces repeated text	var_name [, var_name...]
	Represents code supplied by user	void main (void) { ... }

## RECOMMENDED READING

This user's guide describes how to use MCP661 Line Driver Demo Board. Other useful documents are listed below. The following Microchip documents are available and recommended as supplemental reference resources.

### **MCP661/2/3/5 Data Sheet, “60 MHz, 6 mA Op Amps”, (DS22194)**

Gives detailed information on the op amp family that is used as the DUT on the MCP661 Line Driver Demo Board.

## THE MICROCHIP WEB SITE

Microchip provides online support via our web site at [www.microchip.com](http://www.microchip.com). This web site is used as a means to make files and information easily available to customers. Accessible by using your favorite Internet browser, the web site contains the following information:

- **Product Support** – Data sheets and errata, application notes and sample programs, design resources, user's guides and hardware support documents, latest software releases and archived software
- **General Technical Support** – Frequently Asked Questions (FAQs), technical support requests, online discussion groups, Microchip consultant program member listing
- **Business of Microchip** – Product selector and ordering guides, latest Microchip press releases, listing of seminars and events, listings of Microchip sales offices, distributors and factory representatives

## CUSTOMER SUPPORT

Users of Microchip products can receive assistance through several channels:

- Distributor or Representative
- Local Sales Office
- Field Application Engineer (FAE)
- Technical Support
- Development Systems Information Line

Customers should contact their distributor, representative or field application engineer for support. Local sales offices are also available to help customers. A listing of sales offices and locations is included in the back of this document.

Technical support is available through the web site at: <http://support.microchip.com>

## DOCUMENT REVISION HISTORY

### **Revision A (November 2009)**

- Initial Release of this Document.

# MCP661 Line Driver Demo Board User's Guide

---

NOTES:



## Chapter 1. Product Overview

### 1.1 INTRODUCTION

The MCP661 Line Driver Demo Board is described by the following:

- Assembly # : 114-00270-R1
- Order # : MCP661DM-LD
- Name: MCP661 Line Driver Demo Board

Items discussed in this chapter include:

- Kit Contents
- Intended Use
- Description

### 1.2 KIT CONTENTS

- Assembled printed circuit board, 102-00270
- Important Information "Read First"



**FIGURE 1-1:** MCP661 Line Driver Demo Board Kit Contents.

# MCP661 Line Driver Demo Board User's Guide

## 1.3 INTENDED USE

The MCP661 Line Driver Demo Board shows the MCP661 used in a very basic application for high speed op amps; a 50Ω line (coax) driver. It gives:

- A 30 MHz solution
- High speed PCB layout techniques
- A means to test AC response, step response and distortion

The application circuit implemented on this PCB is discussed briefly in the MCP661/2/3/5 data sheet's application circuit section.

## 1.4 DESCRIPTION

### 1.4.1 Simplified Circuit

Figure 1-2 shows a simplified circuit diagram of the MCP661 Line Driver Demo Board. Details of the power supply and connectors have been left out.

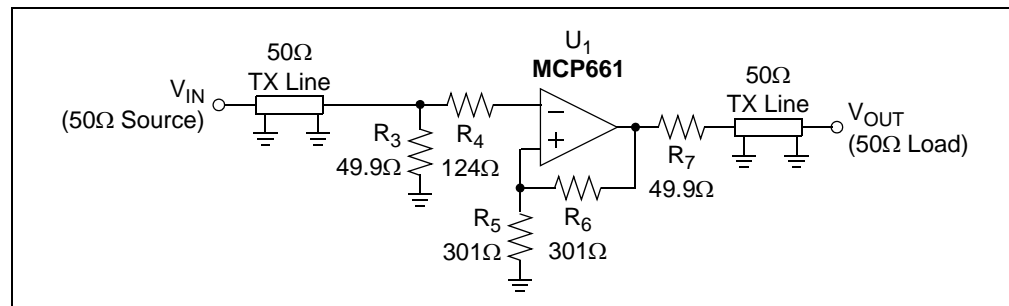

**FIGURE 1-2:** Simplified Circuit Diagram.

The 50Ω source drives the matched 50Ω transmission line at the input; R<sub>3</sub> provides this match. Thus, the input transmission line can be treated as a simple connection for circuit analysis (ignoring the time delay).

R<sub>4</sub> provides matched input resistances for U<sub>1</sub>'s inputs. It also sets a pole around 100 MHz, since U<sub>1</sub>'s C<sub>CM</sub> is about 9 pF.

U<sub>1</sub> (MCP661) is set at a gain of 2 V/V so that the overall gain is 1 V/V (R<sub>7</sub> and the Load attenuate the signal by 0.5 V/V). U<sub>1</sub>'s large output current makes it possible to drive the back-matched output transmission line (R<sub>7</sub>, the 50Ω line and the 50Ω load at the far end) to more than ±2V (the load at the far end sees ±1V).

U<sub>1</sub>'s output headroom limits would be V<sub>OL</sub> = -2.3V and V<sub>OH</sub> = +2.3V, leaving some design room for the ±2V signal. The open-loop gain (A<sub>OL</sub>) typically does not decrease significantly with a 100Ω load. The maximum power dissipated by the op amp is about 48 mW, so the temperature rise (for the MCP661 in the SOIC-8 package) is under 8°C.

The output transmission line can be treated as a simple connection for circuit analysis (ignoring the time delay).

## 1.4.2 Power Supply

Figure 1-3 shows the power supply circuitry.  $R_1$  and  $R_2$  provide high frequency isolation of the supply lines. They also help with series resonances in the supplies.  $C_1$  and  $C_2$  provide the bulk bypassing, while  $C_3$  and  $C_4$  provide the local bypassing, for  $U_1$  (MCP661).

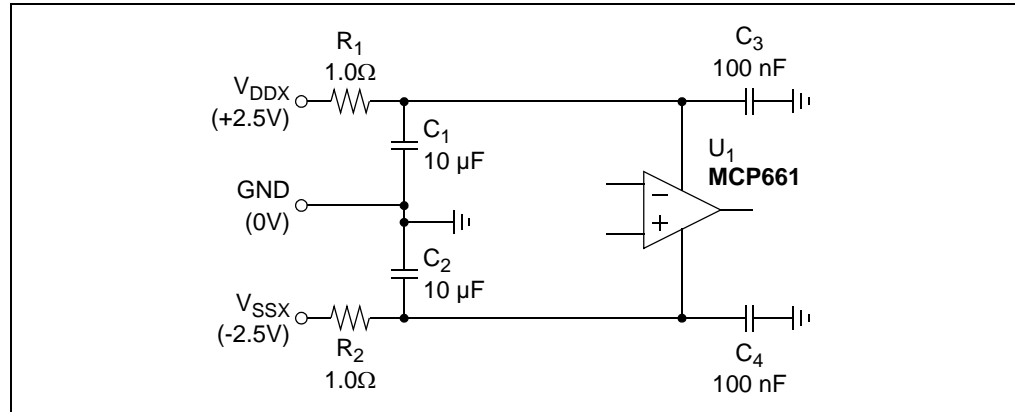

**FIGURE 1-3:** Power Supply.

## 1.4.3 Connectors and Transmission Lines

The power supplies use surface mount test points to connect to the lab supplies. The signal input and output are connected via BNC receptacles (and coax cables) to 50Ω lab equipment.

The PCB has two 50Ω transmission lines between the BNC receptacles and the matching resistors ( $R_3$  and  $R_7$  in Figure 1-2). They are 100 mils (2.54 mm) wide, which is a value commonly used for standard FR4 PCBs with only two layers. These lines are as long as possible; they end at the matching resistors (to avoid parasitic capacitance issues).

# MCP661 Line Driver Demo Board User's Guide

---

NOTES:

---

---

## Chapter 2. Installation and Operation

---

---

### 2.1 INTRODUCTION

This chapter shows how to set up and operate the MCP661 Line Driver Demo Board. Items discussed in this chapter include:

- Required Tools
- Configuring the Lab Equipment and PCB

### 2.2 REQUIRED TOOLS

- Lab Power Supply with dual outputs (one tracks the other):
  - For +2.5V, 0V and -2.5V
- Sine Wave Source (function generator, network analyzer, spectrum analyzer, etc):
  - Sine wave output to 100 MHz, or so
  - 50 $\Omega$  output impedance
  - -2.5V to +2.5V minimum range
- Signal Analyzer (oscilloscope, network analyzer, spectrum analyzer, etc):
  - 50 $\Omega$  input impedance
  - At least 100 MHz bandwidth

# MCP661 Line Driver Demo Board User's Guide

## 2.3 CONFIGURING THE LAB EQUIPMENT AND PCB

Lab equipment is connected to this board as shown in Figure 2-1. The BNC receptacles and (surface mount) test points allow lab equipment to be connected to these boards.

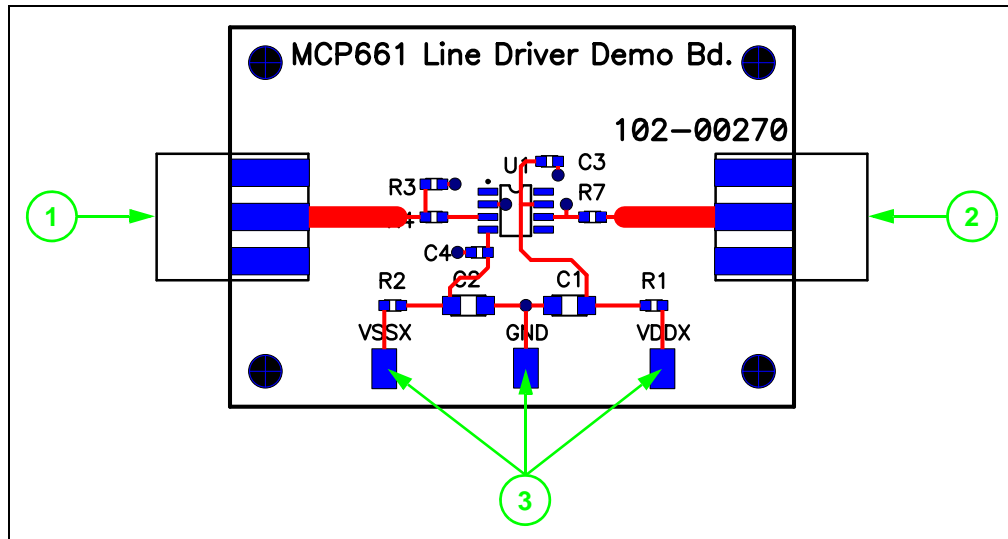

**FIGURE 2-1:** Lab Equipment Connections.

The arrows and numbers in the drawing signify the following:

1. BNC Recepticle for  $V_{IN}$ .
2. BNC Recepticle for  $V_{OUT}$ .
3.  $\pm 2.5V$  Power Supplies, with GND, for U1 (MCP661).
  - a)  $V_{DDX} = +2.5V$ .
  - b)  $GND = 0V$ .
  - c)  $V_{SSX} = -2.5V$ .



# MCP661 LINE DRIVER DEMO BOARD USER'S GUIDE

---

---

## Appendix A. Schematics and Layouts

---

---

### A.1 INTRODUCTION

This appendix contains the schematic and layouts for the MCP661 Line Driver Demo Board.

- Board – Schematic
- Board – Top Silk Screen, Top Solder Mask and Top Metal
- Board – Top Silk Screen and Top Solder Mask
- Board – Bottom Metal (Top View)
- Board – Bottom Metal (Bottom View)

The Gerber files for this board are available on the Microchip website ([www.microchip.com](http://www.microchip.com)) and are contained in the zip file "00270R1\_Gerbers.zip".





## A.3 BOARD – TOP SILK SCREEN, TOP SOLDER MASK AND TOP METAL

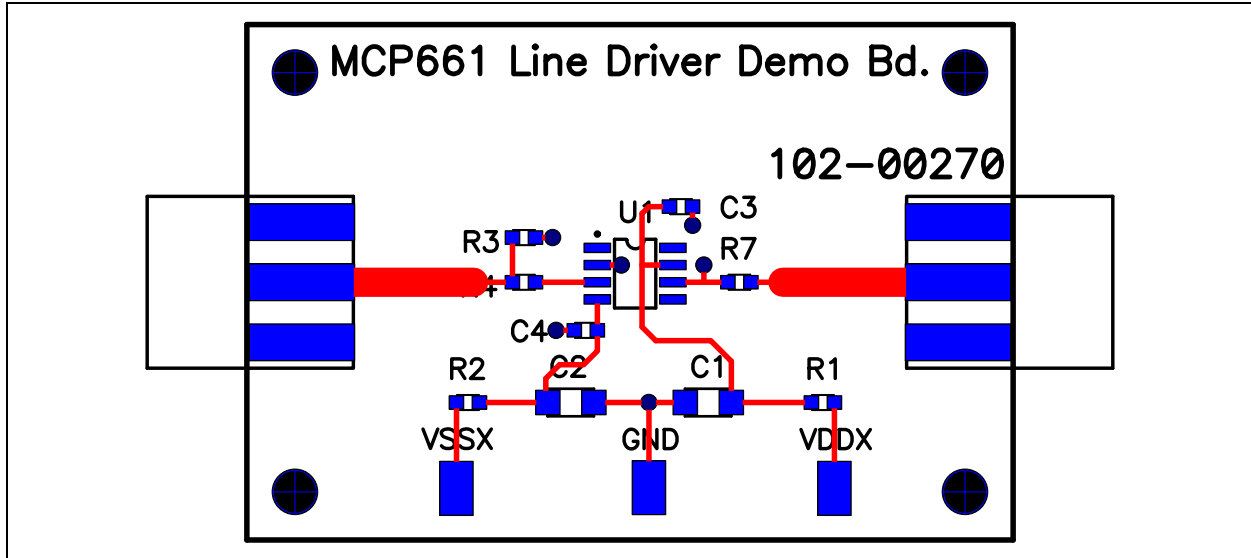

## A.4 BOARD – TOP SILK SCREEN AND TOP SOLDER MASK

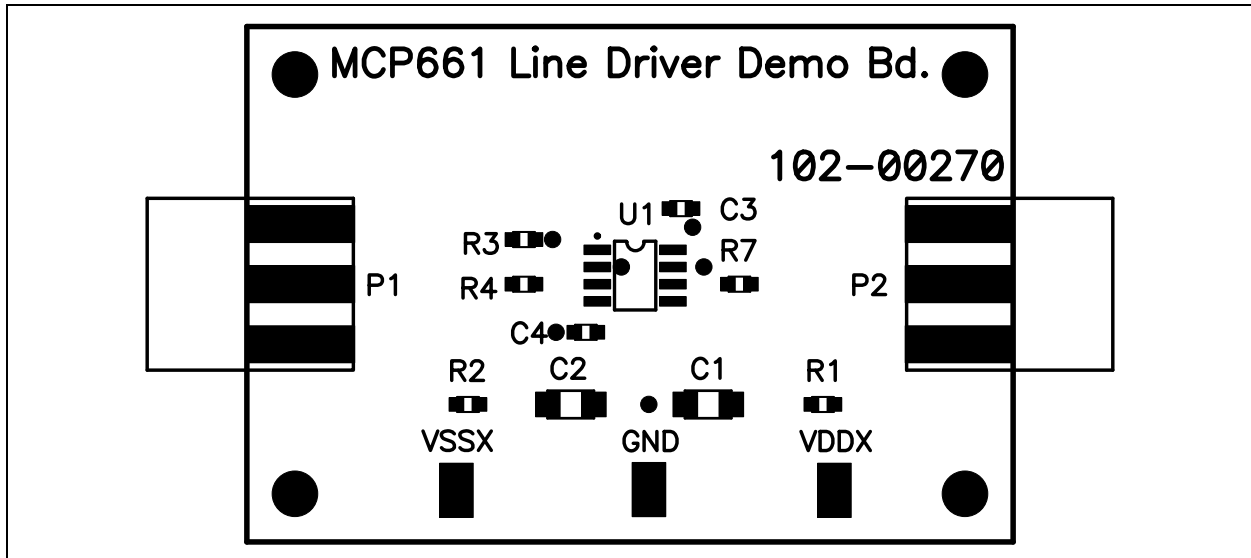

# MCP661 Line Driver Demo Board User's Guide

## A.5 BOARD – BOTTOM METAL LAYER (TOP VIEW)

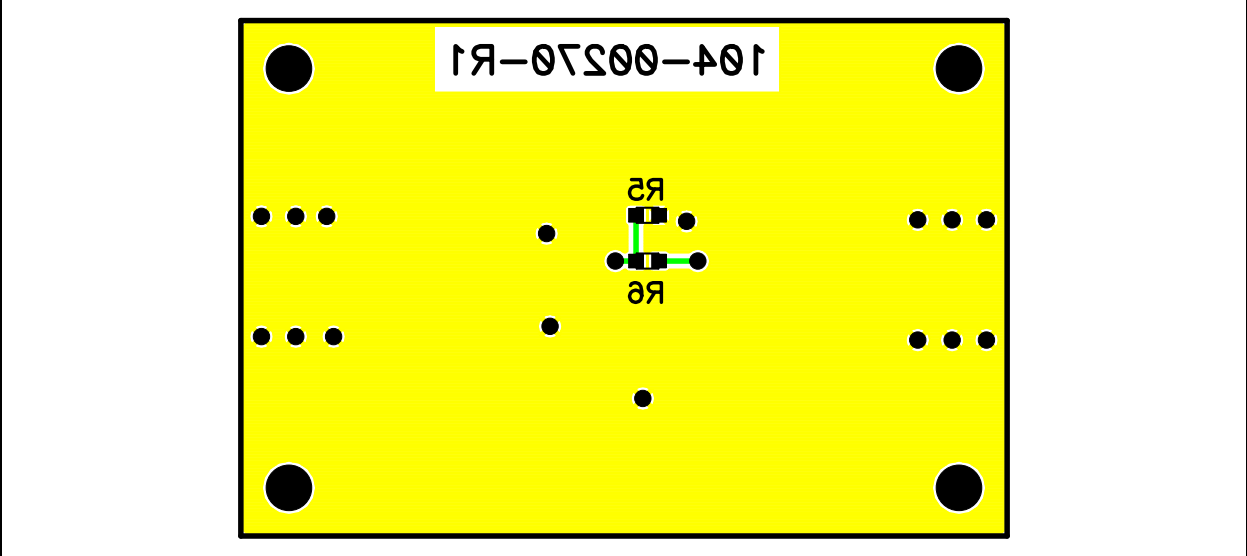

## A.6 BOARD – BOTTOM METAL LAYER (BOTTOM VIEW)

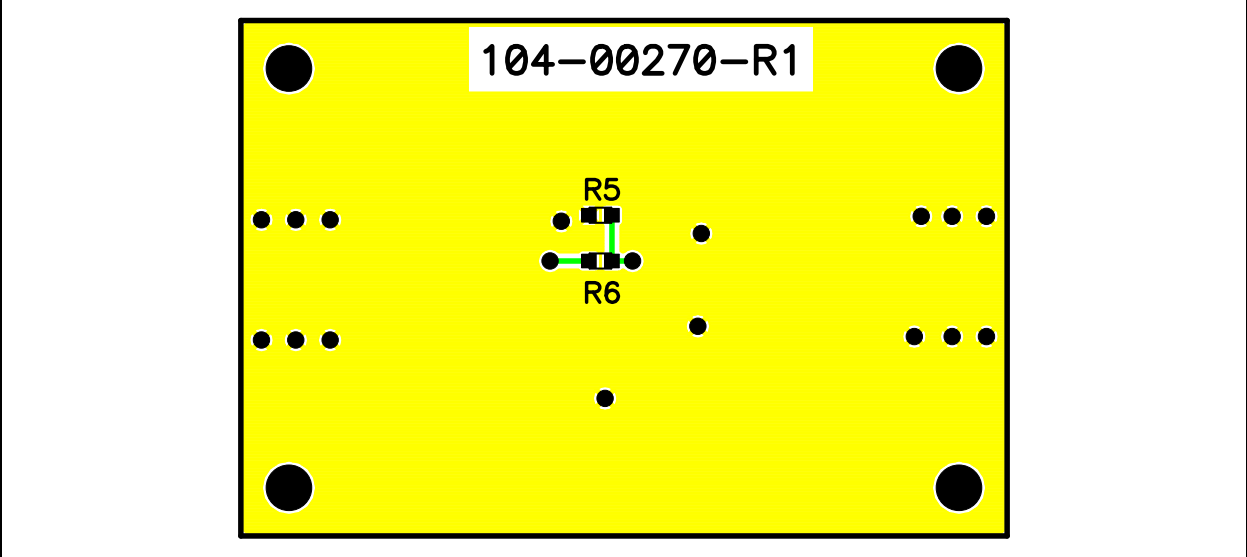

**Appendix B. Bill Of Materials (BOM)**

**B.1 MCP661 LINE DRIVER DEMO BOARD BOM**

The BOM in Table B-1 shows all of the components assembled on the PCB. Table B-2 shows alternate components that can be placed on this PCB (after modification).

**TABLE B-1: BILL OF MATERIALS FOR ASSEMBLED PCB**

Qty.	Reference Designator	Description	Manufacturer	Part Number
2	C3, C4	100 nF, 0603 SMD, X7R, 16V, 10%	Panasonic®-ECG	ECJ-1VB1C104K
2	C1, C2	10 µF, 1206 SMD, X7R, 16V, 10%	Panasonic-ECG	ECJ-3YX1C106K
2	P1, P2	BNC Recepticle, 50Ω, Top Mount (1)	Amphenol	031-5329-52RFX
2	R3, R7	49.9Ω, 0603 SMD, 1%, 1/10W	Yageo®	RC0603FR-0749R9L
1	R4	124Ω, 0603 SMD, 1%, 1/10W	Yageo	RC0603FR-07124RL
2	R5, R6	301Ω, 0603 SMD, 1%, 1/10W	Yageo	RC0603FR-07301RL
2	R1, R2	1.0Ω, 0603 SMD, 5%, 1/10W	Yageo	RC0603JR-071RL
3	TP1 – TP3	SMD, Test Point	Keystone Electronics®	5016
1	U1	MCP661, SOIC-8, Single Op Amp	Microchip Technology Inc.	MCP661-E/SN
1	PCB	2 layer PCB (2.23 in x 1.50 in)	Microchip Technology Inc.	102-00270
4	(for PCB mounting)	Hemispherical Bumpon Standoff, 0.44 in x 0.20 in	3M	SJ-5003 (BLACK)

**Note 1:** These are mounted on the side to reduce strain on the cables in the lab.

**2:** The components listed in this Bill of Materials are representative of the PCB assembly. The released BOM used in manufacturing uses all RoHS-compliant components.

**TABLE B-2: BILL OF MATERIALS FOR ALTERNATE COMPONENTS**

Qty.	Reference Designator	Description	Manufacturer	Part Number
0	(for PCB mounting)	Stand-off, Hex, 0.500", 4 x 40 Thread, Nylon, 0.285" max. O.D.	Keystone Electronics	1902C
0	(for PCB mounting)	Machine Screw, Phillips, 4 x 40 Thread, 1/4" long, Nylon	Building Fasteners	NY PMS 440 0025 PH

**Note 1:** The components listed in this Bill of Materials are representative of the PCB assembly. The released BOM used in manufacturing uses all RoHS-compliant components.



## WORLDWIDE SALES AND SERVICE

### AMERICAS

**Corporate Office**  
2355 West Chandler Blvd.  
Chandler, AZ 85224-6199  
Tel: 480-792-7200  
Fax: 480-792-7277  
Technical Support:  
<http://support.microchip.com>  
Web Address:  
[www.microchip.com](http://www.microchip.com)

**Atlanta**  
Duluth, GA  
Tel: 678-957-9614  
Fax: 678-957-1455

**Boston**  
Westborough, MA  
Tel: 774-760-0087  
Fax: 774-760-0088

**Chicago**  
Itasca, IL  
Tel: 630-285-0071  
Fax: 630-285-0075

**Cleveland**  
Independence, OH  
Tel: 216-447-0464  
Fax: 216-447-0643

**Dallas**  
Addison, TX  
Tel: 972-818-7423  
Fax: 972-818-2924

**Detroit**  
Farmington Hills, MI  
Tel: 248-538-2250  
Fax: 248-538-2260

**Kokomo**  
Kokomo, IN  
Tel: 765-864-8360  
Fax: 765-864-8387

**Los Angeles**  
Mission Viejo, CA  
Tel: 949-462-9523  
Fax: 949-462-9608

**Santa Clara**  
Santa Clara, CA  
Tel: 408-961-6444  
Fax: 408-961-6445

**Toronto**  
Mississauga, Ontario,  
Canada  
Tel: 905-673-0699  
Fax: 905-673-6509

### ASIA/PACIFIC

**Asia Pacific Office**  
Suites 3707-14, 37th Floor  
Tower 6, The Gateway  
Harbour City, Kowloon  
Hong Kong  
Tel: 852-2401-1200  
Fax: 852-2401-3431

**Australia - Sydney**  
Tel: 61-2-9868-6733  
Fax: 61-2-9868-6755

**China - Beijing**  
Tel: 86-10-8528-2100  
Fax: 86-10-8528-2104

**China - Chengdu**  
Tel: 86-28-8665-5511  
Fax: 86-28-8665-7889

**China - Hong Kong SAR**  
Tel: 852-2401-1200  
Fax: 852-2401-3431

**China - Nanjing**  
Tel: 86-25-8473-2460  
Fax: 86-25-8473-2470

**China - Qingdao**  
Tel: 86-532-8502-7355  
Fax: 86-532-8502-7205

**China - Shanghai**  
Tel: 86-21-5407-5533  
Fax: 86-21-5407-5066

**China - Shenyang**  
Tel: 86-24-2334-2829  
Fax: 86-24-2334-2393

**China - Shenzhen**  
Tel: 86-755-8203-2660  
Fax: 86-755-8203-1760

**China - Wuhan**  
Tel: 86-27-5980-5300  
Fax: 86-27-5980-5118

**China - Xiamen**  
Tel: 86-592-2388138  
Fax: 86-592-2388130

**China - Xian**  
Tel: 86-29-8833-7252  
Fax: 86-29-8833-7256

**China - Zhuhai**  
Tel: 86-756-3210040  
Fax: 86-756-3210049

### ASIA/PACIFIC

**India - Bangalore**  
Tel: 91-80-3090-4444  
Fax: 91-80-3090-4080

**India - New Delhi**  
Tel: 91-11-4160-8631  
Fax: 91-11-4160-8632

**India - Pune**  
Tel: 91-20-2566-1512  
Fax: 91-20-2566-1513

**Japan - Yokohama**  
Tel: 81-45-471- 6166  
Fax: 81-45-471-6122

**Korea - Daegu**  
Tel: 82-53-744-4301  
Fax: 82-53-744-4302

**Korea - Seoul**  
Tel: 82-2-554-7200  
Fax: 82-2-558-5932 or  
82-2-558-5934

**Malaysia - Kuala Lumpur**  
Tel: 60-3-6201-9857  
Fax: 60-3-6201-9859

**Malaysia - Penang**  
Tel: 60-4-227-8870  
Fax: 60-4-227-4068

**Philippines - Manila**  
Tel: 63-2-634-9065  
Fax: 63-2-634-9069

**Singapore**  
Tel: 65-6334-8870  
Fax: 65-6334-8850

**Taiwan - Hsin Chu**  
Tel: 886-3-6578-300  
Fax: 886-3-6578-370

**Taiwan - Kaohsiung**  
Tel: 886-7-536-4818  
Fax: 886-7-536-4803

**Taiwan - Taipei**  
Tel: 886-2-2500-6610  
Fax: 886-2-2508-0102

**Thailand - Bangkok**  
Tel: 66-2-694-1351  
Fax: 66-2-694-1350

### EUROPE

**Austria - Wels**  
Tel: 43-7242-2244-39  
Fax: 43-7242-2244-393

**Denmark - Copenhagen**  
Tel: 45-4450-2828  
Fax: 45-4485-2829

**France - Paris**  
Tel: 33-1-69-53-63-20  
Fax: 33-1-69-30-90-79

**Germany - Munich**  
Tel: 49-89-627-144-0  
Fax: 49-89-627-144-44

**Italy - Milan**  
Tel: 39-0331-742611  
Fax: 39-0331-466781

**Netherlands - Drunen**  
Tel: 31-416-690399  
Fax: 31-416-690340

**Spain - Madrid**  
Tel: 34-91-708-08-90  
Fax: 34-91-708-08-91

**UK - Wokingham**  
Tel: 44-118-921-5869  
Fax: 44-118-921-5820

03/26/09

Компания «Life Electronics» занимается поставками электронных компонентов импортного и отечественного производства от производителей и со складов крупных дистрибьюторов Европы, Америки и Азии.

С конца 2013 года компания активно расширяет линейку поставок компонентов по направлению коаксиальный кабель, кварцевые генераторы и конденсаторы (керамические, пленочные, электролитические), за счёт заключения дистрибьюторских договоров

Мы предлагаем:

- Конкуренеспособные цены и скидки постоянным клиентам.
- Специальные условия для постоянных клиентов.
- Подбор аналогов.
- Поставку компонентов в любых объемах, удовлетворяющих вашим потребностям.
- Приемлемые сроки поставки, возможна ускоренная поставка.
- Доставку товара в любую точку России и стран СНГ.
- Комплексную поставку.
- Работу по проектам и поставку образцов.
- Формирование склада под заказчика.
- Сертификаты соответствия на поставляемую продукцию (по желанию клиента).
- Тестирование поставляемой продукции.
- Поставку компонентов, требующих военную и космическую приемку.
- Входной контроль качества.
- Наличие сертификата ISO.

В составе нашей компании организован Конструкторский отдел, призванный помогать разработчикам, и инженерам.

Конструкторский отдел помогает осуществить:

- Регистрацию проекта у производителя компонентов.
- Техническую поддержку проекта.
- Защиту от снятия компонента с производства.
- Оценку стоимости проекта по компонентам.
- Изготовление тестовой платы монтаж и пусконаладочные работы.



Тел: +7 (812) 336 43 04 (многоканальный)

Email: [org@lifeelectronics.ru](mailto:org@lifeelectronics.ru)