

**LOW POWER LOW OFFSET VOLTAGE SINGLE COMPARATOR****AS331****General Description**

The AS331 consists of a single precision voltage comparator with a typical input offset voltage of 1.0mV and high voltage gain. It is specifically designed to operate from a single power supply over wide range of voltages. Operation from split power supply is also possible and the low power supply current drain is independent of the magnitude of the power supply voltage.

The AS331 is available in standard SOT-23-5 package.

**Features**

- Wide Supply Voltage Range
  - Single Supply: 2V to 36V
  - Dual Supplies:  $\pm 1V$  to  $\pm 18V$
- Low Supply Current at  $V_{CC}=5V$ : 0.4mA
- Low Input Bias Current: 25nA (Typical)
- Low Input Offset Current: 5nA (Typical)
- Low Input Offset Voltage: 1mV (Typical)
- Input Common Mode Voltage Range Includes Ground
- Differential Input Voltage Range Equals to the Power Supply Voltage
- Low Output Saturation Voltage at 4mA: 200mV (Typical)
- Open Collector Output

**Applications**

- Battery Charger
- Cordless Telephone
- Switching Power Supply
- DC-DC Module
- PC Motherboard
- Communication Equipment

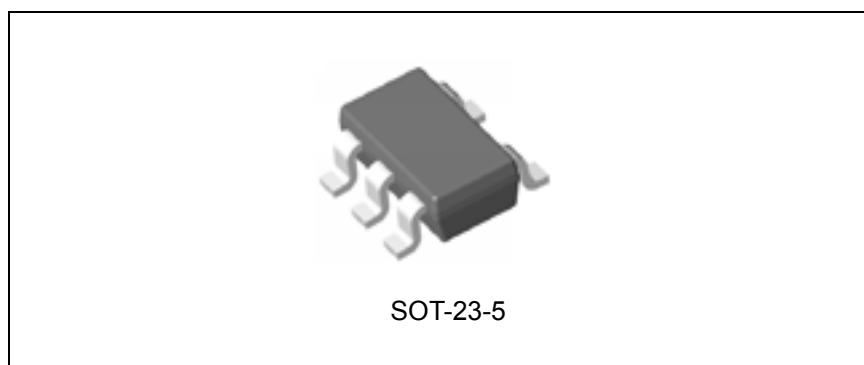


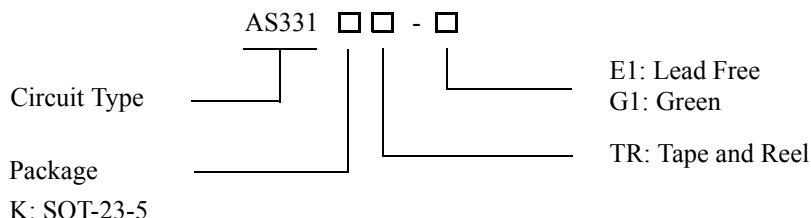
Figure 1. Package Type of AS331





**LOW POWER LOW OFFSET VOLTAGE SINGLE COMPARATOR AS331**

**Ordering Information**



Package	Temperature Range	Part Number		Marking ID		Packing Type
		Lead Free	Green	Lead Free	Green	
SOT-23-5	-40 to 85°C	AS331KTR-E1	AS331KTR-G1	EEA	GEA	Tape & Reel

BCD Semiconductor's Pb-free products, as designated with "E1" suffix in the part number, are RoHS compliant. Products with "G1" suffix are available in green package.

**Absolute Maximum Ratings (Note 1)**

Parameter	Symbol	Value	Unit
Supply Voltage	V <sub>CC</sub>	40	V
Differential Input Voltage	V <sub>ID</sub>	40	V
Input Voltage	V <sub>IN</sub>	-0.3 to 40	V
Input Current (V <sub>IN</sub> <-0.3V) (Note 2)	I <sub>IN</sub>	50	mA
Output Short-circuit Current to Ground		Continuous	
Power Dissipation (T <sub>A</sub> =25°C)	P <sub>D</sub>	620	mW
Operating Junction Temperature	T <sub>J</sub>	150	°C
Storage Temperature	T <sub>STG</sub>	-65 to 150	°C
Lead Temperature (Soldering, 10sec)	T <sub>LEAD</sub>	260	°C

Note 1: Stresses greater than those listed under "Absolute Maximum Ratings" may cause permanent damage to the device. These are stress ratings only, and functional operation of the device at these or any other conditions beyond those indicated under "Recommended Operating Conditions" is not implied. Exposure to "Absolute Maximum Ratings" for extended periods may affect device reliability.

Note 2: This input current will only exist when the voltage at any of the input leads is driven negative. It is due to the collector-base junction of the input PNP transistors becoming forward biased and thereby acting as input diode clamps. In addition to this diode action, there is also lateral NPN parasitic transistor action on the IC chip. This transistor action can cause the output voltages of the comparators to go to the V+ voltage level (or to ground for a large overdrive) for the time duration that an input is driven negative. This is not destructive and normal output states will re-establish when the input voltage, which was negative, again returns to a value greater than -0.3V (at 25°C).



**LOW POWER LOW OFFSET VOLTAGE SINGLE COMPARATOR AS331**

**Recommended Operating Conditions**

Parameter	Symbol	Min	Max	Unit
Supply Voltage	$V_{CC}$	2	36	V
Operating Ambient Temperature Range	$T_A$	-40	85	°C

**Electrical Characteristics**

$V_{CC}=5V$ ,  $GND=0V$ ,  $T_A=25^{\circ}C$ , unless otherwise specified. **Bold** typeface applies over  $T_A=-40$  to  $85^{\circ}C$  (Note 3)

Parameter	Symbol	Conditions	Min	Typ	Max	Unit	
Input Offset Voltage	$V_{OS}$	$V_{OUT}=1.4V$ , $V_{CC}=5$ to $30V$		1	5	mV	
					<b>7.0</b>		
Input Bias Current	$I_B$	$I_{IN+}$ or $I_{IN-}$ with output in linear range, $V_{CM}=0V$		25	250	nA	
					<b>400</b>		
Input Offset Current	$I_{IO}$	$I_{IN+}-I_{IN-}$ , $V_{CM}=0V$		5	50	nA	
					<b>200</b>		
Input Common Mode Voltage Range (Note 4)		$V_{CC}=30V$	0		$V_{CC}-1.5$	V	
Supply Current	$I_{CC}$	$R_L=\infty$	$V_{CC}=5V$		0.4	1.0	mA
						<b>2.0</b>	
				$V_{CC}=30V$		0.5	
						<b>3.0</b>	
Voltage Gain	$G_V$	$V_{CC}=15V$ , $R_L \geq 15k\Omega$ , $V_{OUT}=1$ to $11V$	50	200		V/mV	
Large Signal Response Time		$V_{IN}=\text{TTL Logic Swing}$ , $R_L=5.1k\Omega$		200		ns	
Response Time		$R_L=5.1k\Omega$		1.3		$\mu s$	
Output Sink Current	$I_{SINK}$	$V_{IN-}=1V$ , $V_{IN+}=0V$ , $V_{OUT}=1.5V$	6.0	16		mA	
Output Leakage Current	$I_{LEAK}$	$V_{IN-}=0V$ , $V_{IN+}=1V$ , $V_{OUT}=5V$		0.1		nA	
		$V_{IN-}=0V$ , $V_{IN+}=1V$ , $V_{OUT}=30V$			<b>1</b>	$\mu A$	
Saturation Voltage	$V_{SAT}$	$V_{IN-}=1V$ , $V_{IN+}=0V$ , $I_{SINK} \leq 4mA$		200	400	mV	
					<b>500</b>		

Note 3: These specifications are limited to  $-40^{\circ}C \leq T_A \leq 85^{\circ}C$ . Limits over temperature are guaranteed by design, but not tested in production.

Note 4: The input common mode voltage of either input signal voltage should not be allowed to go negatively by more than 0.3V (at 25°C). The upper end of the common mode voltage range is  $V_{CC}-1.5V$  (at 25°C), but either or both inputs can go to +36V without damages, independent of the magnitude of the  $V_{CC}$ .



**LOW POWER LOW OFFSET VOLTAGE SINGLE COMPARATOR**

**AS331**

**Typical Performance Characteristics**

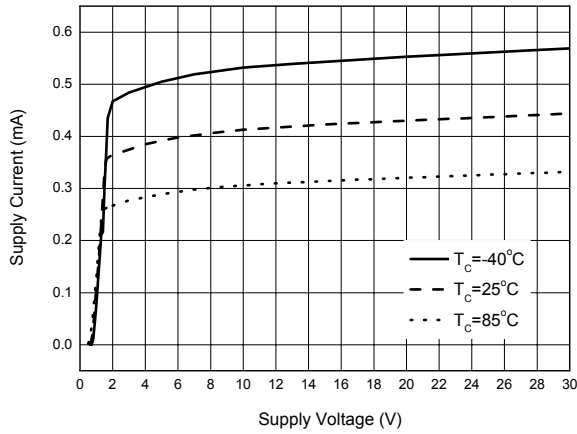


Figure 4. Supply Current vs. Supply Voltage

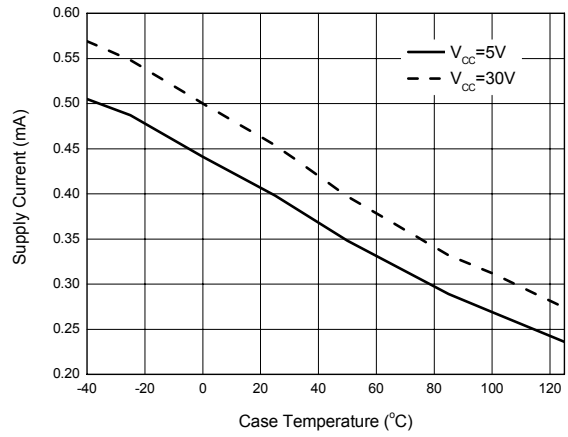


Figure 5. Supply Current vs. Case Temperature

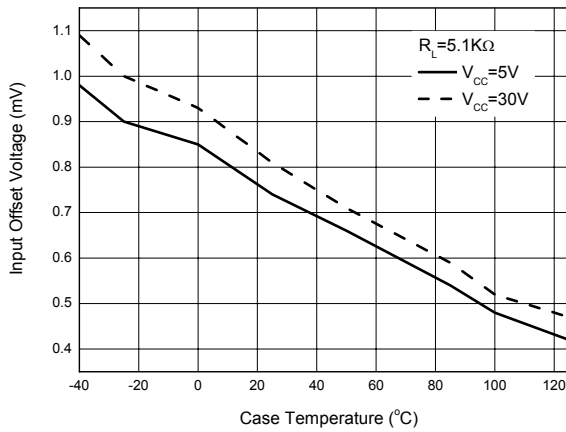


Figure 6. Input Offset Voltage vs. Case Temperature

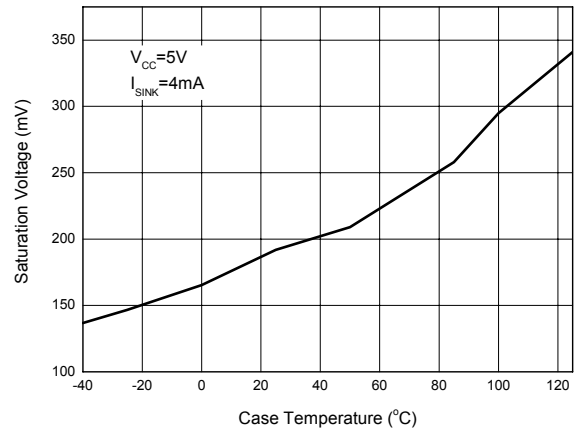


Figure 7. Saturation Voltage vs. Case Temperature



**LOW POWER LOW OFFSET VOLTAGE SINGLE COMPARATOR**

**AS331**

**Typical Performance Characteristics (Continued)**

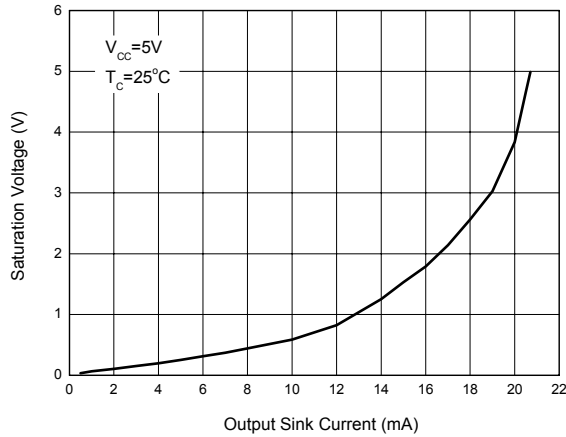


Figure 8. Saturation Voltage vs. Output Sink Current

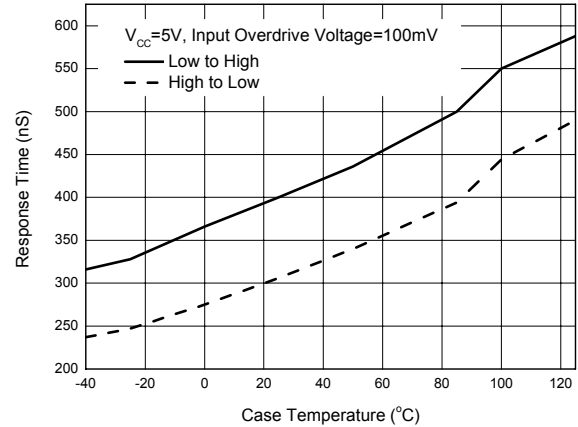


Figure 9. Response Time vs. Case Temperature

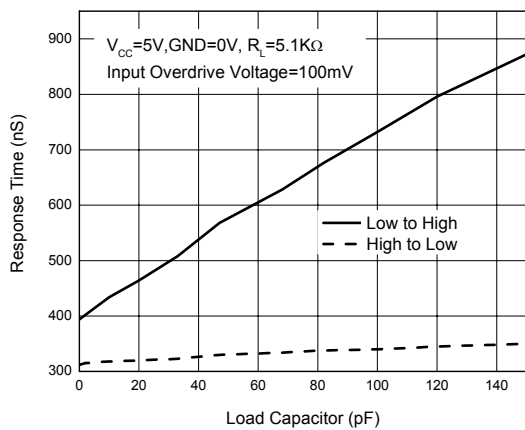


Figure 10. Response Time vs. Load Capacitor

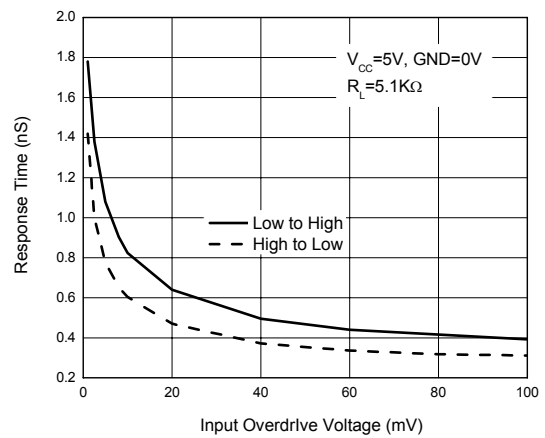


Figure 11. Response Time vs. Input Overdrive Voltage



**LOW POWER LOW OFFSET VOLTAGE SINGLE COMPARATOR**

**AS331**

**Typical Performance Characteristics (Continued)**

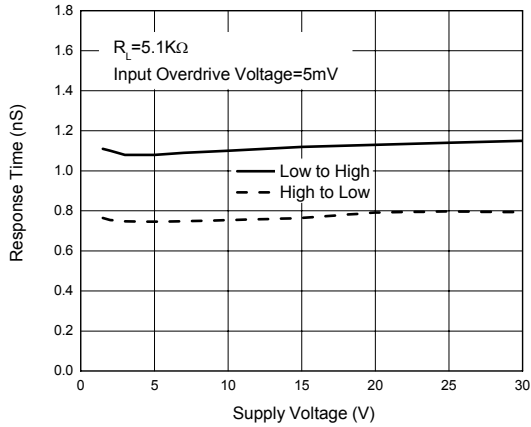


Figure 12. Response Time vs. Supply Voltage

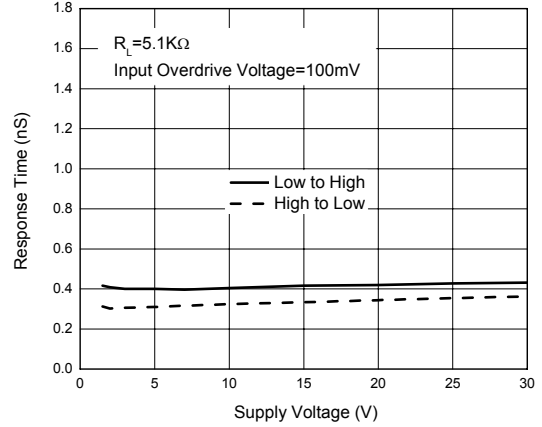


Figure 13. Response Time vs. Supply Voltage

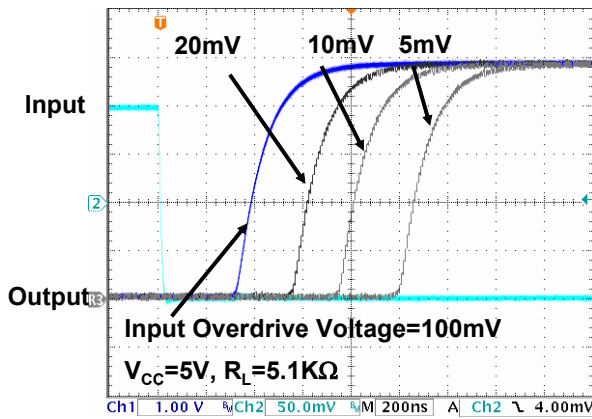


Figure 14. Response Time for Positive Transition

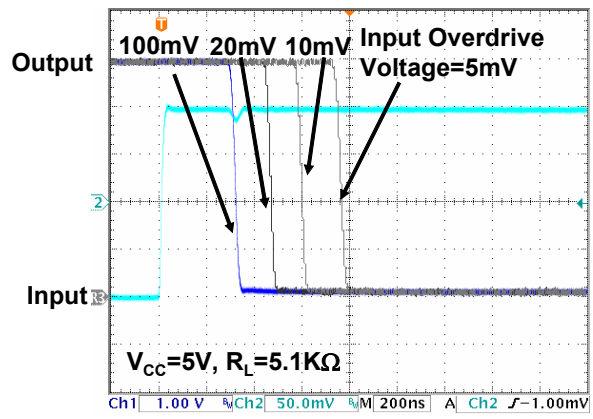


Figure 15. Response Time for Negative Transition

**LOW POWER LOW OFFSET VOLTAGE SINGLE COMPARATOR AS331**

Typical Performance Characteristics (Continued)

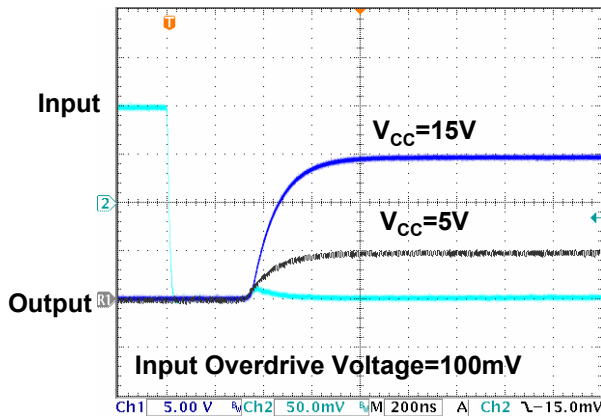


Figure 16. Response Time for Positive Transition

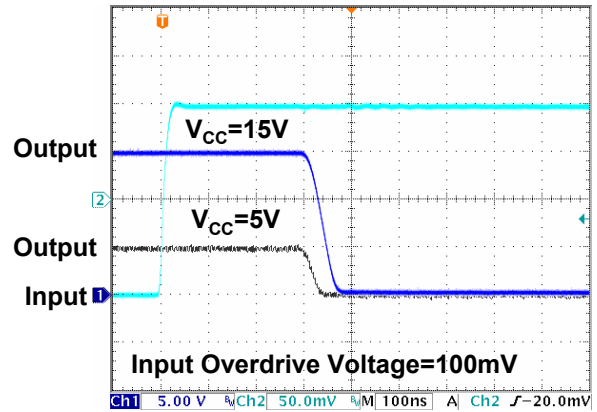


Figure 17. Response Time for Negative Transition

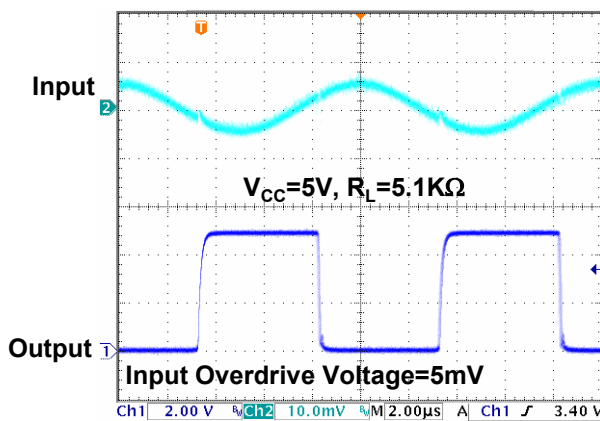


Figure 18. 100kHz Response

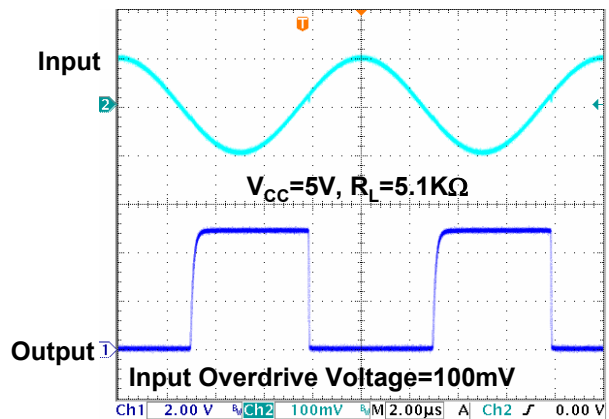


Figure 19. 100kHz Response



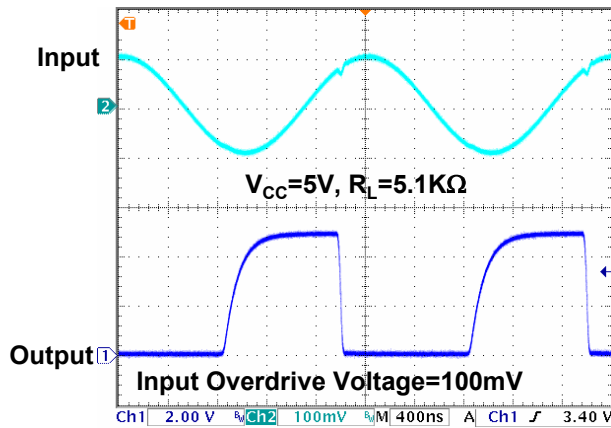
**Typical Performance Characteristics (Continued)**

Figure 20. 500kHz Response

**Typical Application**

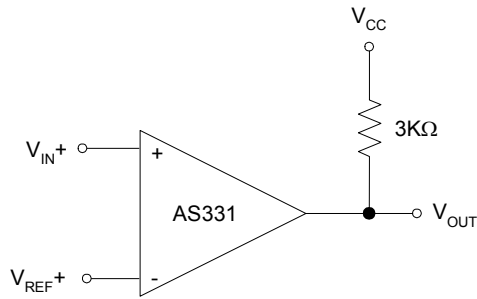


Figure 21. Basic Comparator

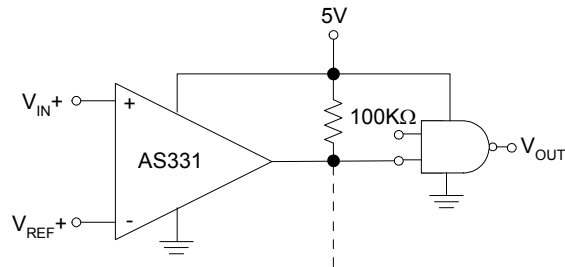


Figure 22. Driving CMOS

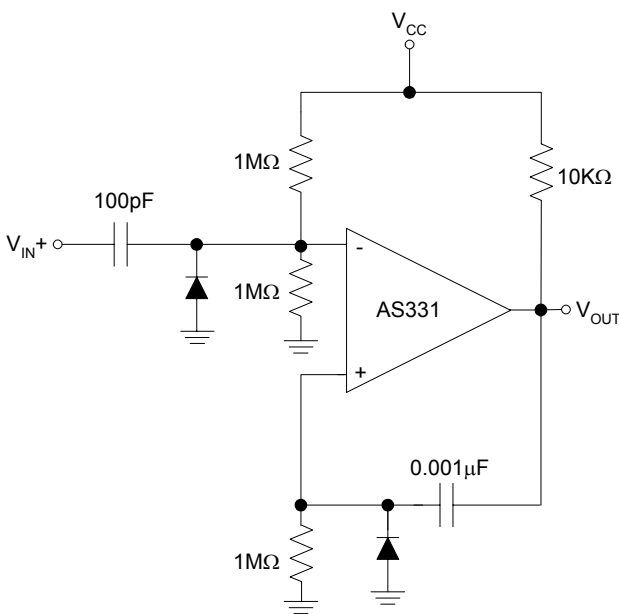


Figure 23. One Shot Multivibrator

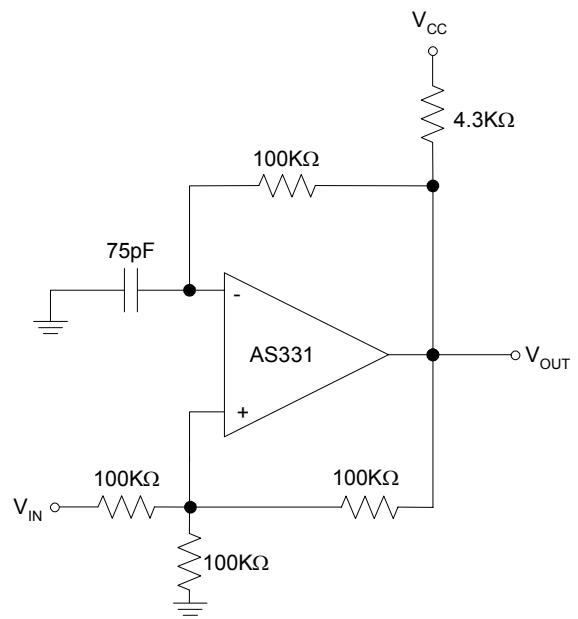


Figure 24. Squarewave Oscillator

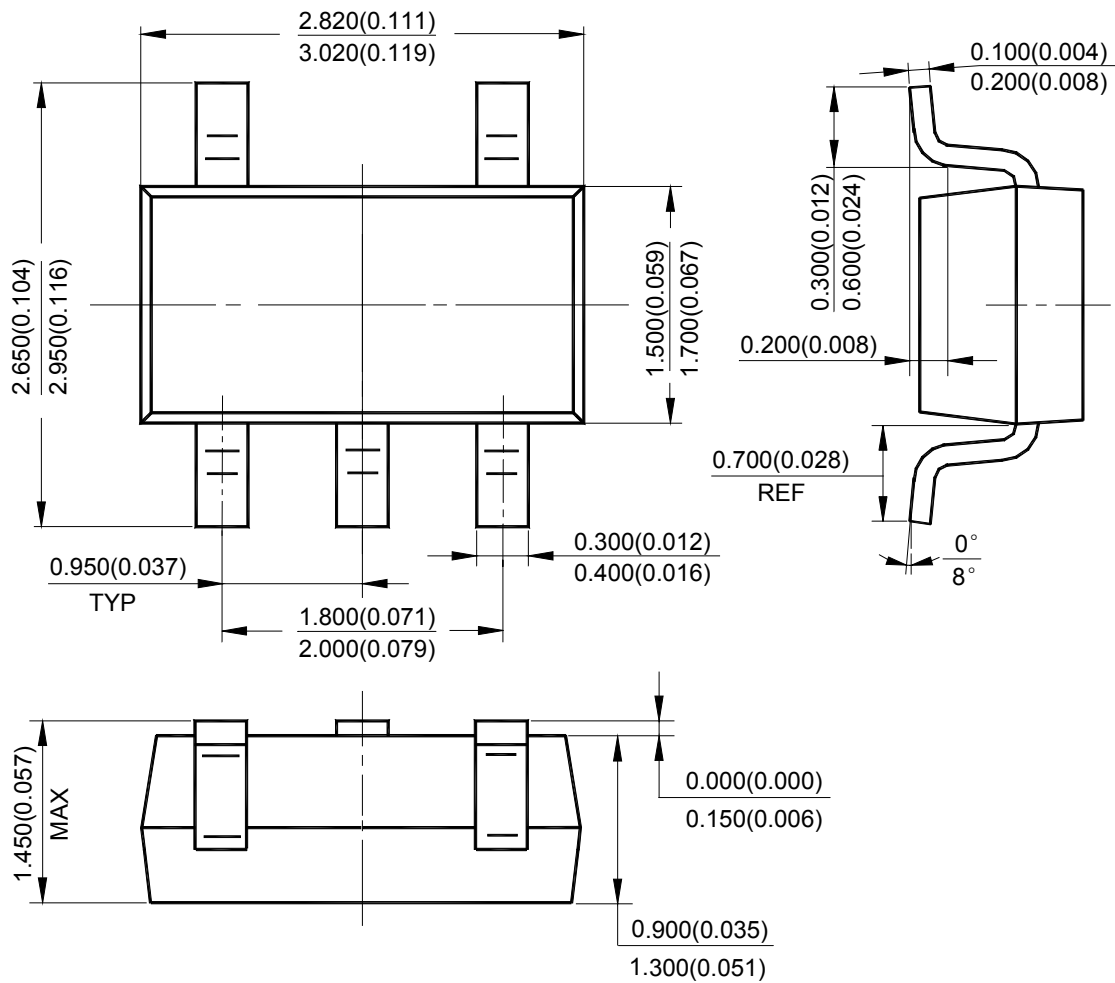


**LOW POWER LOW OFFSET VOLTAGE SINGLE COMPARATOR** **AS331**

**Mechanical Dimensions**

**SOT-23-5**

**Unit: mm(inch)**





## **BCD Semiconductor Manufacturing Limited**

<http://www.bcdsemi.com>

### **IMPORTANT NOTICE**

BCD Semiconductor Manufacturing Limited reserves the right to make changes without further notice to any products or specifications herein. BCD Semiconductor Manufacturing Limited does not assume any responsibility for use of any its products for any particular purpose, nor does BCD Semiconductor Manufacturing Limited assume any liability arising out of the application or use of any its products or circuits. BCD Semiconductor Manufacturing Limited does not convey any license under its patent rights or other rights nor the rights of others.

---

#### **MAIN SITE**

##### **- Headquarters**

##### **BCD Semiconductor Manufacturing Limited**

No. 1600, Zi Xing Road, Shanghai ZiZhu Science-based Industrial Park, 200241, China  
Tel: +86-21-24162266, Fax: +86-21-24162277

##### **- Wafer Fab**

##### **Shanghai SIM-BCD Semiconductor Manufacturing Co., Ltd.**

800 Yi Shan Road, Shanghai 200233, China  
Tel: +86-21-6485 1491, Fax: +86-21-5450 0008

#### **REGIONAL SALES OFFICE**

##### **Shenzhen Office**

##### **Shanghai SIM-BCD Semiconductor Manufacturing Co., Ltd., Shenzhen Office**

Unit A Room 1203, Skyworth Bldg., Gaoxin Ave. 1.S., Nanshan District, Shenzhen, China  
Tel: +86-755-8826 7951  
Fax: +86-755-8826 7865

##### **Taiwan Office**

##### **BCD Semiconductor (Taiwan) Company Limited**

4F, 298-1, Rui Guang Road, Nei-Hu District, Taipei, Taiwan  
Tel: +886-2-2656 2808  
Fax: +886-2-2656 2806

##### **USA Office**

##### **BCD Semiconductor Corp.**

30920 Huntwood Ave. Hayward, CA 94544, USA  
Tel : +1-510-324-2988  
Fax: +1-510-324-2788

Компания «Life Electronics» занимается поставками электронных компонентов импортного и отечественного производства от производителей и со складов крупных дистрибьюторов Европы, Америки и Азии.

С конца 2013 года компания активно расширяет линейку поставок компонентов по направлению коаксиальный кабель, кварцевые генераторы и конденсаторы (керамические, пленочные, электролитические), за счёт заключения дистрибьюторских договоров

Мы предлагаем:

- Конкуренспособные цены и скидки постоянным клиентам.
- Специальные условия для постоянных клиентов.
- Подбор аналогов.
- Поставку компонентов в любых объемах, удовлетворяющих вашим потребностям.
- Приемлемые сроки поставки, возможна ускоренная поставка.
- Доставку товара в любую точку России и стран СНГ.
- Комплексную поставку.
- Работу по проектам и поставку образцов.
- Формирование склада под заказчика.
- Сертификаты соответствия на поставляемую продукцию (по желанию клиента).
- Тестирование поставляемой продукции.
- Поставку компонентов, требующих военную и космическую приемку.
- Входной контроль качества.
- Наличие сертификата ISO.

В составе нашей компании организован Конструкторский отдел, призванный помогать разработчикам, и инженерам.

Конструкторский отдел помогает осуществить:

- Регистрацию проекта у производителя компонентов.
- Техническую поддержку проекта.
- Защиту от снятия компонента с производства.
- Оценку стоимости проекта по компонентам.
- Изготовление тестовой платы монтаж и пусконаладочные работы.



Тел: +7 (812) 336 43 04 (многоканальный)

Email: [org@lifeelectronics.ru](mailto:org@lifeelectronics.ru)