

KAD2708C

8-Bit, 275/210/170/105MSPS A/D Converter

FN6812
 Rev 1.00
 April 14, 2011

The KAD2708C is the industry's lowest power, 8-bit, 275MSPS, high performance Analog-to-Digital converter. It is designed with Intersil's proprietary FemtoCharge™ technology on a standard CMOS process. The KAD2708C offers high dynamic performance (49.2dBFS SNR @ $f_{IN} = 138\text{MHz}$) while consuming less than 265mW. Features include an over-range indicator and a selectable divide-by-2 input clock divider. The KAD2708C is one member of a pin-compatible family offering 8 and 10-bit ADCs with sample rates from 105MSPS to 350MSPS and LVCMOS or LVDS-compatible outputs (Table 1). This family of products is available in 68-pin RoHS-compliant QFN packages with exposed paddle. Performance is specified over the full industrial temperature range (-40°C to +85°C).

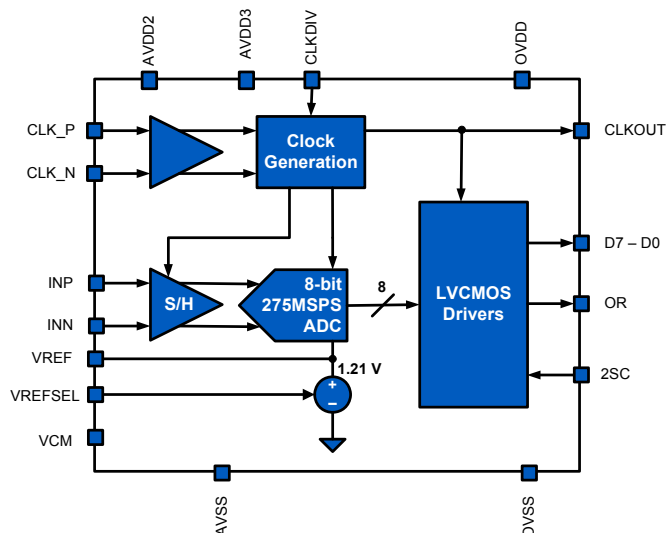

Features

- On-Chip Reference
- Internal Track and Hold
- 1.5V_{P-P} Differential Input Voltage
- 600MHz Analog Input Bandwidth
- Two's Complement or Binary Output
- Over-Range Indicator
- Selectable ÷2 Clock Input
- LVCMOS Outputs

Applications

- High-Performance Data Acquisition
- Portable Oscilloscope
- Medical Imaging
- Cable Head Ends
- Power-Amplifier Linearization
- Radar and Satellite Antenna Array Processing
- Broadband Communications
- Point-to-Point Microwave Systems
- Communications Test Equipment

Key Specifications

- SNR of 49.2dBFS at $f_S = 275\text{MSPS}$, $f_{IN} = 138\text{MHz}$
- SFDR of 66.6dBc at $f_S = 275\text{MSPS}$, $f_{IN} = 138\text{MHz}$
- Power Consumption ≤ 265mW at $f_S = 275\text{MSPS}$

Pin-Compatible Family

TABLE 1. PIN-COMPATIBLE PRODUCTS

RESOLUTION, SPEED	LVDS OUTPUTS	LVCMOS OUTPUTS
8 Bits 350MSPS	KAD2708L-35	
10 Bits 275MSPS	KAD2710L-27	KAD2710C-27
8 Bits 275MSPS	KAD2708L-27	KAD2708C-27
10 Bits 210MSPS	KAD2710L-21	KAD2710C-21
8 Bits 210MSPS	KAD2708L-21	KAD2708C-21
10 Bits 170MSPS	KAD2710L-17	KAD2710C-17
8 Bits 170MSPS	KAD2708L-17	KAD2708C-17
10 Bits 105MSPS	KAD2710L-10	KAD2710C-10
8 Bits 105MSPS	KAD2708L-10	KAD2708C-10

Ordering Information

PART NUMBER	SPEED (MSPS)	TEMP. RANGE (°C)	PACKAGE	PKG. DWG. #
KAD2708C-27Q68	275	-40 to +85	68 Ld QFN	L68.10x10B
KAD2708C-21Q68	210	-40 to +85	68 Ld QFN	L68.10x10B
KAD2708C-17Q68	170	-40 to +85	68 Ld QFN	L68.10x10B
KAD2708C-10Q68	105	-40 to +85	68 Ld QFN	L68.10x10B

NOTES:

1. These Intersil Pb-free plastic packaged products employ special Pb-free material sets, molding compounds/die attach materials, and 100% matte tin plate plus anneal (e3 termination finish, which is RoHS compliant and compatible with both SnPb and Pb-free soldering operations). Intersil Pb-free products are MSL classified at Pb-free peak reflow temperatures that meet or exceed the Pb-free requirements of IPC/JEDEC J STD-020.
2. For Moisture Sensitivity Level (MSL), please see device information page for [KAD2708C-10](#), [KAD2708C-17](#), [KAD2708C-21](#) and [KAD2708C-27](#). For more information on MSL please see techbrief [TB363](#).

Table of Contents

Absolute Maximum Ratings	3
Thermal Information	3
Electrical Specifications	3
Digital Specifications	4
Timing Diagram	6
Timing Specifications	6
ESD	6
Pin Descriptions	7
Pin Configuration	8
Typical Performance Curves	9
Functional Description	12
Reset	12
Voltage Reference	12
Analog Input	12
Clock Input	13
Jitter	13
Digital Outputs	14
Equivalent Circuits	14
Layout Considerations	15
Split Ground and Power Planes	15
Clock Input Considerations	15
Bypass and Filtering	15
LVCMOS Outputs	15
Unused Inputs	15
Definitions	15
Package Outline Drawing	16

Absolute Maximum Ratings

AVDD2 to AVSS	-0.4V to 2.1V
AVDD3 to AVSS	-0.4V to 3.7V
OVDD2 to OVSS	-0.4V to 2.1V
Analog Inputs to AVSS	-0.4V to AVDD3 + 0.3V
Clock Inputs to AVSS	-0.4V to AVDD2 + 0.3V
Logic Inputs to AVSS (VREFSEL, CLKDIV)	-0.4V to AVDD3 + 0.3V
Logic Inputs to OVSS (RST, 2SC)	-0.4V to OVDD2 + 0.3V
VREF to AVSS	-0.4V to AVDD3 + 0.3V
Analog Output Currents	10mA
Logic Output Currents	10mA
CMOS Output Currents	20mA

CAUTION: Do not operate at or near the maximum ratings listed for extended periods of time. Exposure to such conditions may adversely impact product reliability and result in failures not covered by warranty.

NOTES:

- θ_{JA} is measured in free air with the component mounted on a high effective thermal conductivity test board with "direct attach" features. See Tech Brief [TB379](#).
- For θ_{JC} , the "case temp" location is the center of the exposed metal pad on the package underside.

Thermal Information

Thermal Resistance (Typical, Notes 3, 4)	θ_{JA} (°C/W)	θ_{JC} (°C/W)
68 Ld QFN Package	23	1.8
Operating Temperature	-40°C to +85°C	
Storage Temperature	-65°C to +150°C	
Junction Temperature	+150°C	

Electrical Specifications All specifications apply under the following conditions unless otherwise noted: AVDD2 = 1.8V, AVDD3 = 3.3V, OVDD = 1.8V, T_A = -40°C to +85°C (typical specifications at +25°C), f_{SAMPLE} = 275MSPS, 210MSPS, 170MSPS and 105MSPS, f_{IN} = Nyquist at -0.5dBFS. **Boldface limits apply over the operating temperature range, -40°C to +85°C.**

PARAMETER	SYMBOL	CONDITIONS	KAD2708C-27			KAD2708C-21			KAD2708C-17			KAD2708C-10			UNITS
			MIN (Note 5)	TYP	MAX (Note 5)	MIN (Note 5)	TYP	MAX (Note 5)	MIN (Note 5)	TYP	MAX (Note 5)	MIN (Note 5)	TYP	MAX (Note 5)	
DC SPECIFICATIONS															
Analog Input															
Full-Scale Analog Input Range	V_{FS}		1.4	1.5	1.6	1.4	1.5	1.6	1.4	1.5	1.6	1.4	1.5	1.6	V_{P-P}
Full Scale Range Temp. Drift	A_{VTC}	Full Temp		230			210			198			178		ppm/°C
Common-Mode Output Voltage	V_{CM}			860			860			860			860		mV
Power Requirements															
1.8V Analog Supply Voltage	AVDD2		1.7	1.8	1.9	1.7	1.8	1.9	1.7	1.8	1.9	1.7	1.8	1.9	V
3.3V Analog Supply Voltage	AVDD3		3.15	3.3	3.45	3.15	3.3	3.45	3.15	3.3	3.45	3.15	3.3	3.45	V
1.8V Digital Supply Voltage	OVDD		1.7	1.8	1.9	1.7	1.8	1.9	1.7	1.8	1.9	1.7	1.8	1.9	V
1.8V Analog Supply Current	I_{AVDD2}			44	51		38	42		35	39		29	33	mA
3.3V Analog Supply Current	I_{AVDD3}			41	45		33	37		28	32		21	24	mA
1.8V Digital Supply Current	I_{OVDD}			26	30		25	28		24	27		23	26	mA
Power Dissipation	P_D			261	294		222	248		199	224		163	185	mW
AC SPECIFICATIONS															
Maximum Conversion Rate	f_S MAX		275			210			170			105			MSPS

Electrical Specifications All specifications apply under the following conditions unless otherwise noted: AVDD2 = 1.8V, AVDD3 = 3.3V, OVDD = 1.8V, $T_A = -40^{\circ}\text{C}$ to $+85^{\circ}\text{C}$ (typical specifications at $+25^{\circ}\text{C}$), $f_{\text{SAMPLE}} = 275\text{MSPS}$, 210MSPS , 170MSPS and 105MSPS , $f_{\text{IN}} = \text{Nyquist}$ at -0.5dBFS . **Boldface limits apply over the operating temperature range, -40°C to $+85^{\circ}\text{C}$.** (Continued)

PARAMETER	SYMBOL	CONDITIONS	KAD2708C-27			KAD2708C-21			KAD2708C-17			KAD2708C-10			UNITS
			MIN (Note 5)	TYP	MAX (Note 5)	MIN (Note 5)	TYP	MAX (Note 5)	MIN (Note 5)	TYP	MAX (Note 5)	MIN (Note 5)	TYP	MAX (Note 5)	
Minimum Conversion Rate	f_{S} MIN				50			50			50			50	MSPS
Differential Nonlinearity	DNL		-0.3	± 0.2	0.4	-0.3	± 0.2	0.4	-0.3	± 0.2	0.4	-0.3	± 0.2	0.4	LSB
Integral Nonlinearity	INL		-0.8	± 0.2	0.8	-0.8	± 0.2	0.8	-0.8	± 0.2	0.8	-0.8	± 0.2	0.8	LSB
Signal-to-Noise Ratio	SNR	$f_{\text{IN}} = 10\text{MHz}$		49.5			49.5			49.5			49.5		dBFS
		$f_{\text{IN}} = \text{Nyquist}$	46.5	49.2		46.5	49.2		46.5	49.2		46.5	49.2		dBFS
		$f_{\text{IN}} = 430\text{MHz}$		49.0			49.1			49.1			49.1		dBFS
Signal-to-Noise and Distortion	SINAD	$f_{\text{IN}} = 10\text{MHz}$		49.2			49.5			49.5			49.5		dBFS
		$f_{\text{IN}} = \text{Nyquist}$	46.5	49.2		46.5	49.2		46.5	49.2		46.5	49.2		dBFS
		$f_{\text{IN}} = 430\text{MHz}$		48.9			48.9			49.0			48.9		dBFS
Effective Number of Bits	ENOB	$f_{\text{IN}} = 10\text{MHz}$		7.9			7.9			7.9			7.9		Bits
		$f_{\text{IN}} = \text{Nyquist}$	7.4	7.9		7.4	7.9		7.4	7.9		7.4	7.9		Bits
		$f_{\text{IN}} = 430\text{MHz}$		7.8			7.8			7.8			7.8		Bits
Spurious-Free Dynamic Range	SFDR	$f_{\text{IN}} = 10\text{MHz}$		67.6			69.1			69.1			69.1		dBc
		$f_{\text{IN}} = \text{Nyquist}$	61	66.6		61	69.1		61	69.1		61	69.1		dBc
		$f_{\text{IN}} = 430\text{MHz}$		66.1			69.0			69.0			68.9		dBc
Two-Tone SFDR	2TSFDR	$f_{\text{IN}} = 133\text{MHz}, 135\text{MHz}$		63			65			65			65		dBc
Word Error Rate	WER			10^{-12}			10^{-12}			10^{-12}			10^{-12}		
Full Power Bandwidth	FPBW			600			600			600			600		MHz

NOTE:

5. Compliance to datasheet limits is assured by one or more methods: production test, characterization and/or design.

Digital Specifications

PARAMETER	SYMBOL	CONDITIONS	MIN (Note 6)	TYP	MAX (Note 6)	UNITS
INPUTS						
High Input Voltage (VREFSEL)	VREFSEL V_{IH}		$0.8 \cdot \text{AVDD3}$			V
Low Input Voltage (VREFSEL)	VREFSEL V_{IL}				$0.2 \cdot \text{AVDD3}$	V
Input Current High (VREFSEL)	VREFSEL I_{IH}	$V_{\text{IN}} = \text{AVDD3}$	0	1	10	μA
Input Current Low (VREFSEL)	VREFSEL I_{IL}	$V_{\text{IN}} = \text{AVSS}$	25	65	75	μA
High Input Voltage (CLKDIV)	CLKDIV V_{IH}		$0.8 \cdot \text{AVDD3}$			V
Low Input Voltage (CLKDIV)	CLKDIV V_{IL}				$0.2 \cdot \text{AVDD3}$	V
Input Current High (CLKDIV)	CLKDIV I_{IH}	$V_{\text{IN}} = \text{AVDD3}$	25	65	75	μA
Input Current Low (CLKDIV)	CLKDIV I_{IL}	$V_{\text{IN}} = \text{AVSS}$	0	1	10	μA
High Input Voltage (RST,2SC)	RST,2SC V_{IH}		$0.8 \cdot \text{OVDD2}$			V
Low Input Voltage (RST,2SC)	RST,2SC V_{IL}				$0.2 \cdot \text{OVDD2}$	V
Input Current High (RST,2SC)	RST,2SC I_{IH}	$V_{\text{IN}} = \text{OVDD}$	0	1	10	μA

Digital Specifications (Continued)

PARAMETER	SYMBOL	CONDITIONS	MIN (Note 6)	TYP	MAX (Note 6)	UNITS
Input Current Low (RST,2SC)	RST,2SC I _{IL}	VIN = OVSS	25	50	75	μA
Input Capacitance	C _{DI}			3		pF
CLKP, CLKN P-P Differential Input Voltage	V _{CDI}		0.5		3.6	V _{P-P}
CLKP, CLKN Differential Input Resistance	R _{CDI}			10		MΩ
CLKP, CLKN Common-Mode Input Voltage	V _{CCI}			0.9		V
LVC MOS OUTPUTS						
Voltage Output High	V _{OH}			1.8		V
Voltage Output Low	V _{OL}			0		V
Output Rise Time	t _R			1.8		ns
Output Fall Time	t _F			1.4		ns

NOTE:

6. Compliance to datasheet limits is assured by one or more methods: production test, characterization and/or design.

Timing Diagram

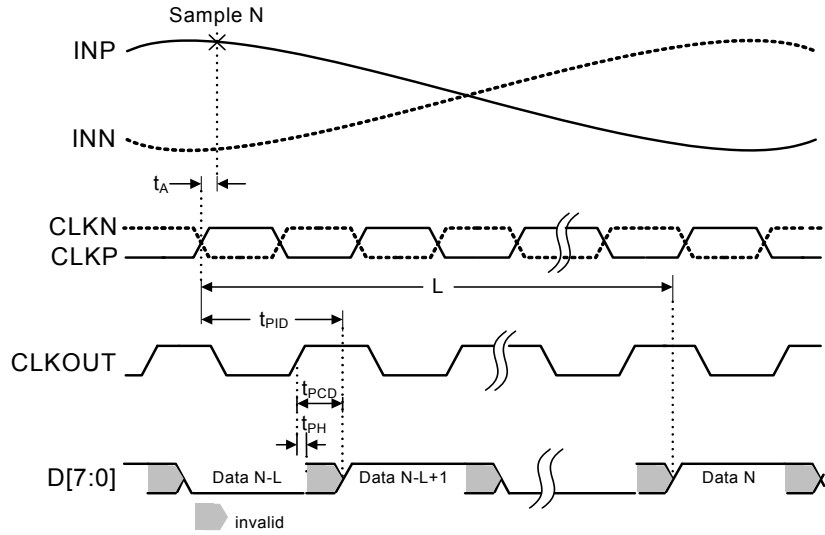

FIGURE 1. LVCMOS TIMING DIAGRAM

Timing Specifications

PARAMETER	SYMBOL	MIN (Note 7)	TYP	MAX (Note 7)	UNITS
Aperture Delay	t_A		1.7		ns
RMS Aperture Jitter	j_A		200		fs
Input Clock to Data Propagation Delay	t_{PID}	3.5	5.0	6.5	ns
Data Hold Time	t_{PH}	-300			ps
Output Clock to Data Propagation Delay	t_{PCD}		2.8	3.7	ns
Latency (Pipeline Delay)	L		28		cycles
Overvoltage Recovery	t_{OVR}		1		cycle

NOTE:

- 7. Compliance to datasheet limits is assured by one or more methods: production test, characterization and/or design.



Electrostatic charge accumulates on humans, tools and equipment and may discharge through any metallic package contacts (pins, balls, exposed paddle, etc.) of an integrated circuit. Industry-standard protection techniques have been utilized in the design of this product. However, reasonable care must be taken in the storage and handling of ESD sensitive products. Contact Intersil for the specific ESD sensitivity rating of this product.

Pin Descriptions

PIN NUMBER	NAME	FUNCTION
1, 14, 18, 20	AVDD2	1.8V Analog Supply
2, 7, 10, 19, 21, 24	AVSS	Analog Supply Return
3	VREF	Reference Voltage Out/In
4	VREFSEL	Reference Voltage Select (0:Int 1:Ext)
5	VCM	Common-Mode Voltage Output
6, 15, 16, 25	AVDD3	3.3V Analog Supply
8, 9	INP, INN	Analog Input Positive, Negative
11-13, 29-36, 37, 39, 42, 46, 48, 50, 52, 54, 56, 58, 62, 63, 67	DNC	Do Not Connect
17	CLKDIV	Clock Divide by Two (Active Low)
22, 23	CLKN, CLKP	Clock Input Complement, True
26, 45, 61	OVSS	Output Supply Return
27, 41, 44, 60	OVDD2	1.8V CMOS Supply
28	RST	Power On Reset (Active Low)
38	D0	LVC MOS Bit 0 (LSB) Output
40	D1	LVC MOS Bit 1 Output
43	CLKOUT	LVC MOS Clock Output
47	D2	LVC MOS Bit 2 Output
49	D3	LVC MOS Bit 3 Output
51	D4	LVC MOS Bit 4 Output
53	D5	LVC MOS Bit 5 Output
55	D6	LVC MOS Bit 6 Output
57	D7	LVC MOS Bit 7 Output
59	OR	Over-Range
64-66		Connect to OVDD2
68	2SC	Two's Complement Select (Active Low)
Exposed Paddle	AVSS	Analog Supply Return

Pin Configuration

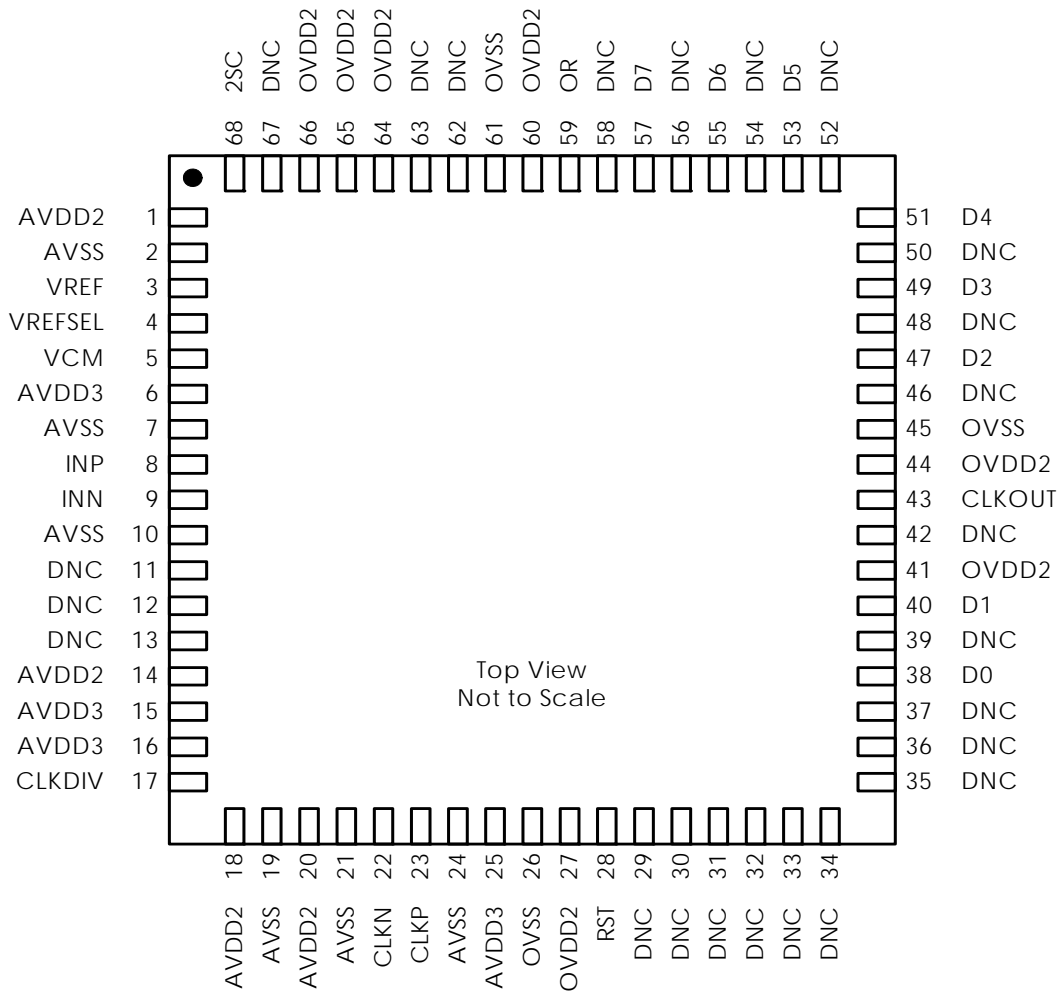

FIGURE 2. PIN CONFIGURATION

Typical Performance Curves AVDD2 = OVDD2 = 1.8V, AVDD3 = 3.3V, T_A = +25°C, f_{SAMPLE} = 275MSPS, f_{IN} = 137MHz, A_{IN} = -0.5dBFS unless noted.

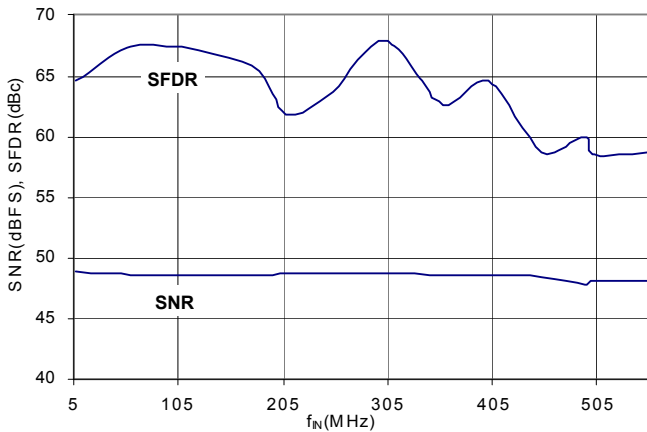

FIGURE 3. SNR AND SFDR vs f_{IN}

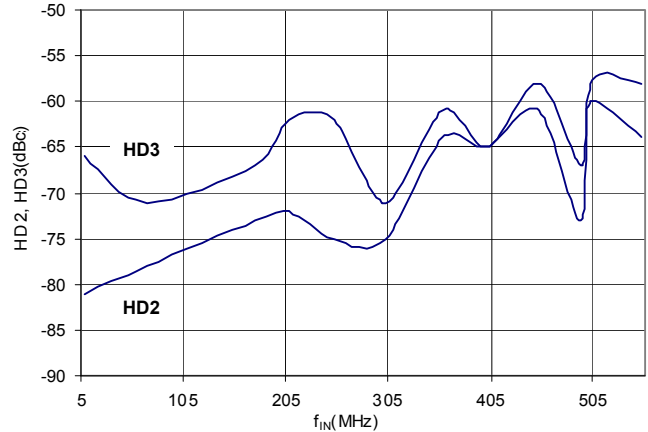

FIGURE 4. HD2 AND HD3 vs f_{IN}

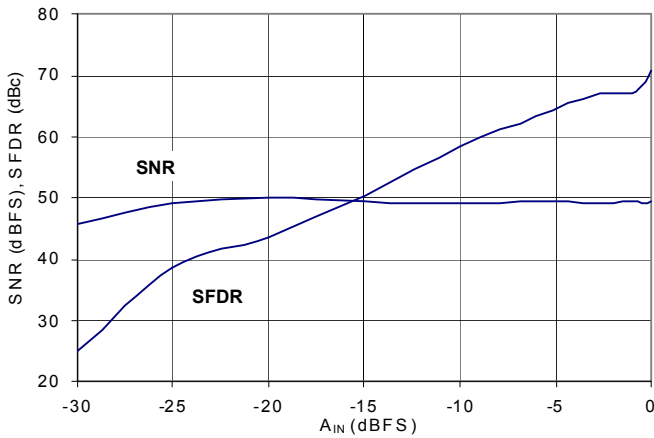

FIGURE 5. SNR AND SFDR vs A_{IN}

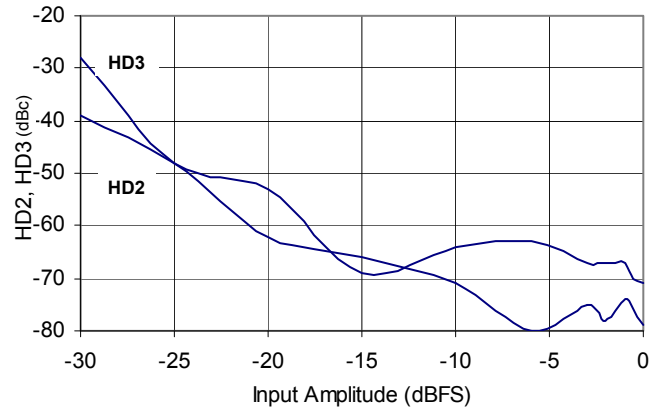

FIGURE 6. HD2 AND HD3 vs A_{IN}

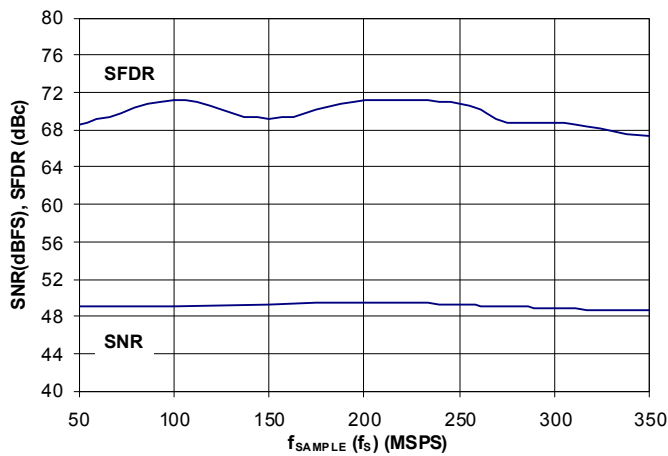

FIGURE 7. SNR AND SFDR vs f_{SAMPLE}

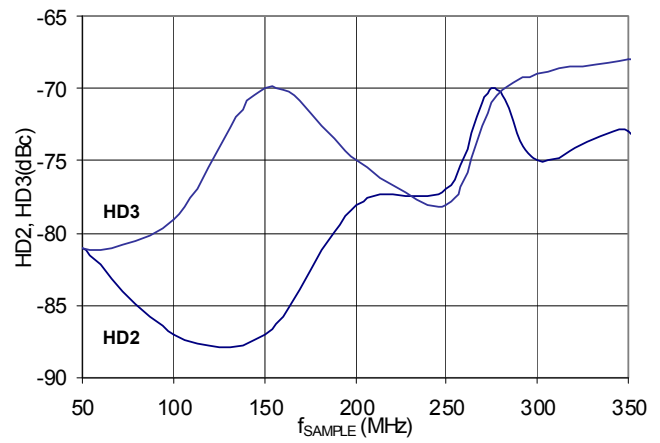

FIGURE 8. HD2 AND HD3 vs f_{SAMPLE}

Typical Performance Curves AVDD2 = OVDD2 = 1.8V, AVDD3 = 3.3V, T_A = +25°C, f_{SAMPLE} = 275MSPS, f_{IN} = 137MHz, A_{IN} = -0.5dBFS unless noted. (Continued)

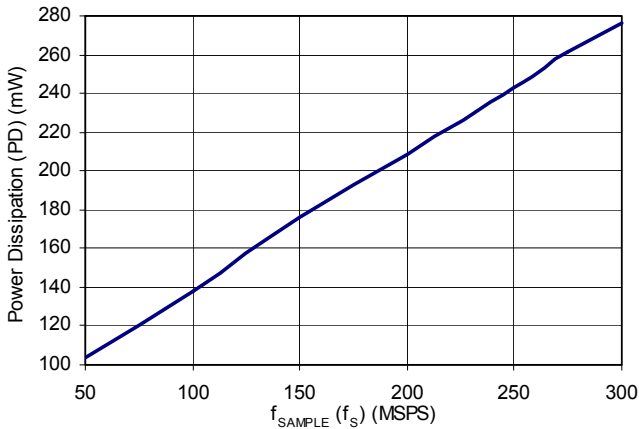

FIGURE 9. POWER DISSIPATION vs f_{SAMPLE}

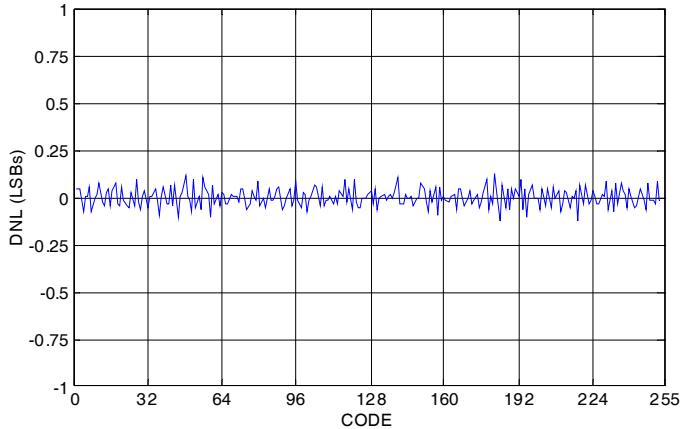

FIGURE 10. DIFFERENTIAL NONLINEARITY vs OUTPUT CODE

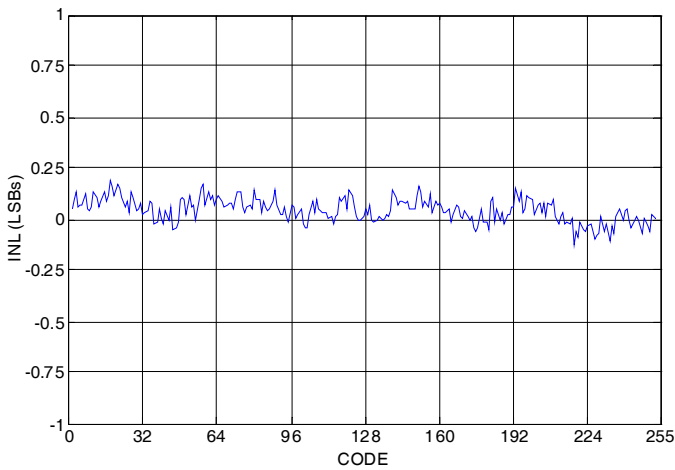

FIGURE 11. INTEGRAL NONLINEARITY vs OUTPUT CODE

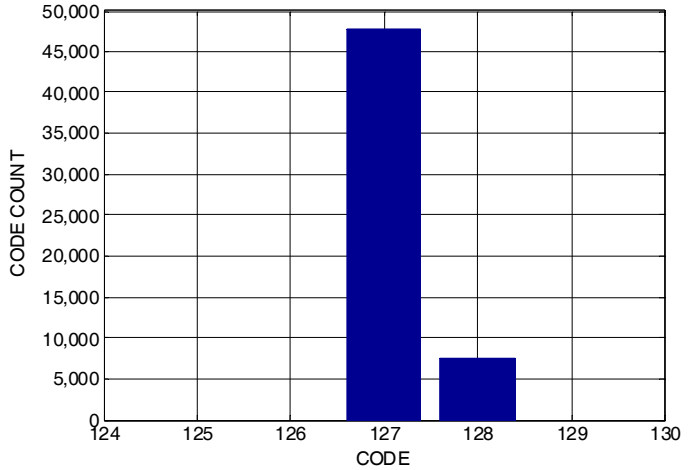

FIGURE 12. NOISE HISTOGRAM

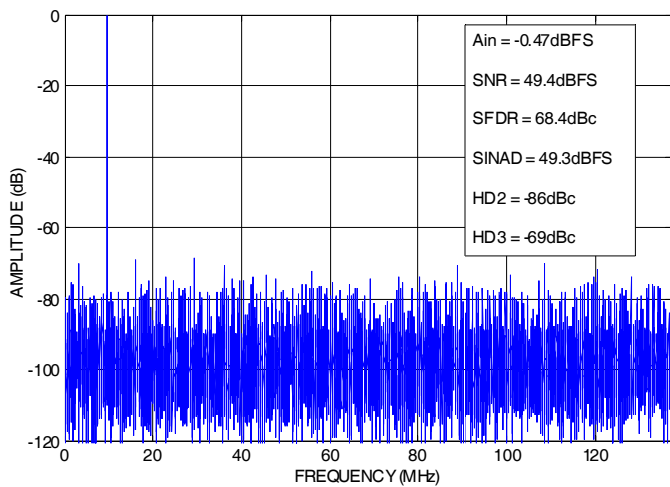

FIGURE 13. OUTPUT SPECTRUM @ 9.865MHz

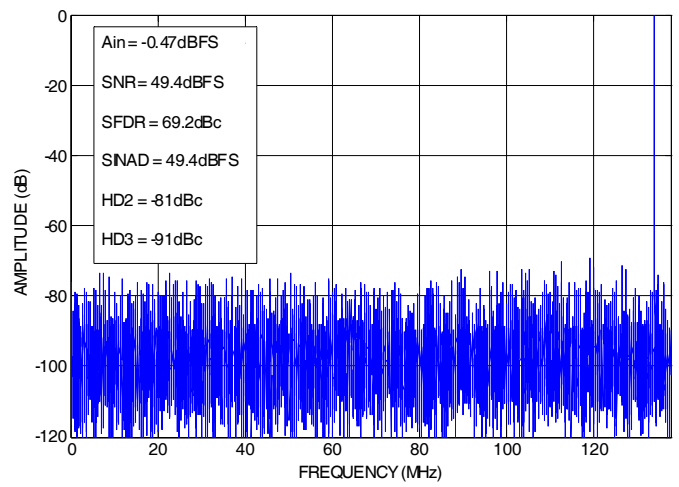

FIGURE 14. OUTPUT SPECTRUM @ 133.805MHz

Typical Performance Curves AVDD2 = OVDD2 = 1.8V, AVDD3 = 3.3V, T_A = +25°C, f_{SAMPLE} = 275MSPS, f_{IN} = 137MHz, A_{IN} = -0.5dBFS unless noted. (Continued)

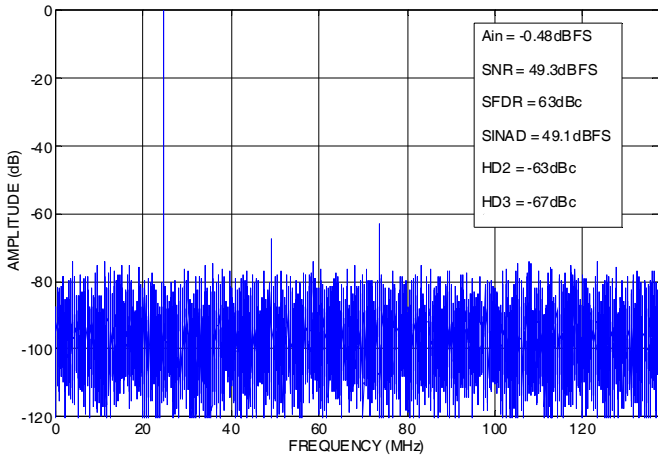

FIGURE 15. OUTPUT SPECTRUM @ 299.645MHz

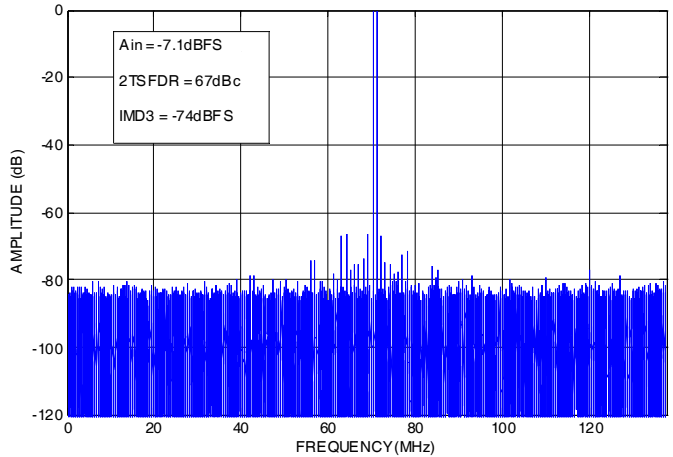

FIGURE 16. TWO-TONE SPECTRUM @ 69MHz, 70MHz

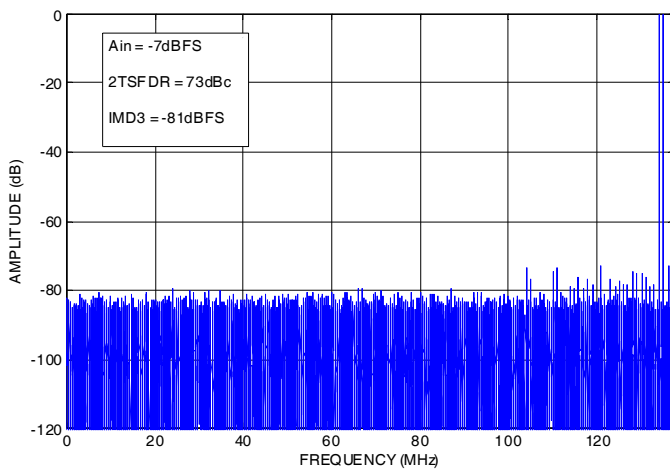

FIGURE 17. TWO-TONE SPECTRUM @ 140MHz, 141MHz

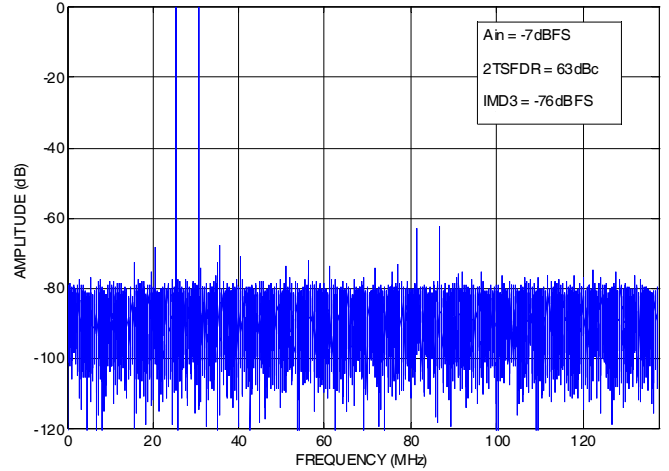

FIGURE 18. TWO-TONE SPECTRUM @ 300MHz, 305MHz

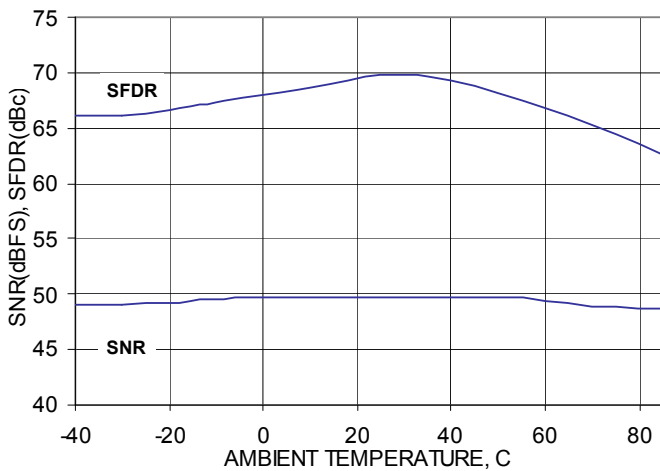

FIGURE 19. SNR AND SFDR vs TEMPERATURE

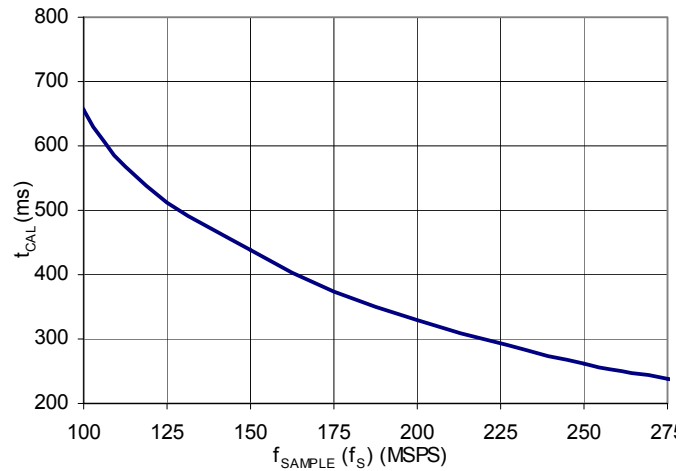

FIGURE 20. CALIBRATION TIME vs f_S

Functional Description

The KAD2708 is an 8-bit, 275MSPS A/D converter in a pipelined architecture. The input voltage is captured by a sample & hold circuit and converted to a unit of charge. Proprietary charge domain techniques are used to compare the input to a series of reference charges. These comparisons determine the digital code for each input value. The converter pipeline requires 24 sample clocks to produce a result. Digital error correction is also applied, resulting in a total latency of 28 clock cycles. This is evident to the user as a latency between the start of a conversion and the data being available on the digital outputs.

At start-up, a self-calibration is performed to minimize gain and offset errors. The reset pin (RST) is initially held low internally at power-up and will remain in that state until the calibration is complete. The clock frequency should remain fixed during this time.

Calibration accuracy is maintained for the sample rate at which it is performed, and therefore should be repeated if the clock frequency is changed by more than 10%. Recalibration can be initiated via the RST pin, or power cycling, at any time.

Reset

Recalibration of the ADC can be initiated at any time by driving the RST pin low for a minimum of one clock cycle. An open-drain driver is recommended.

The calibration sequence is initiated on the rising edge of RST, as shown in Figure 21. The over-range output (OR) is set high once RST is pulled low, and remains in that state until calibration is complete. The OR output returns to normal operation at that time, so it is important that the analog input be within the converter's full-scale range in order to observe the transition. If the input is in an over-range state the OR pin will stay high and it will not be possible to detect the end of the calibration cycle.

While RST is low, the output clock (CLKOUT) stops toggling and is set low. Normal operation of the output clock resumes at the next input clock edge (CLKP/CLKN) after RST is de-asserted. At 275MSPS the nominal calibration time is ~240ms.

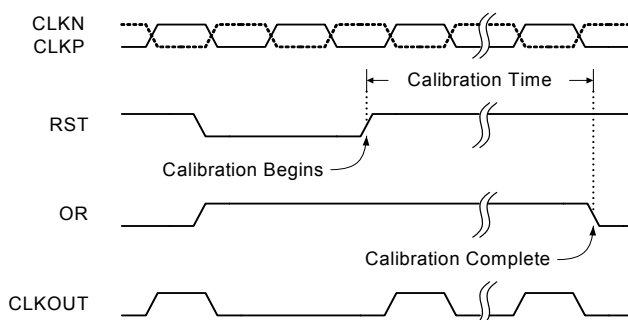

FIGURE 21. CALIBRATION TIMING

Voltage Reference

The VREF pin is the full-scale reference, which sets the full-scale input voltage for the chip and requires a bypass capacitor of 0.1 μ F or larger. An internally generated reference voltage is provided from a bandgap voltage buffer. This buffer can sink or source up to 50 μ A externally.

An external voltage may be applied to this pin to provide a more accurate reference than the internally generated bandgap voltage or to match the full-scale reference among a system of KAD2708C chips. One option in the latter configuration is to use one KAD2708C's internally generated reference as the external reference voltage for the other chips in the system. Additionally, an externally provided reference can be changed from the nominal value to adjust the full-scale input voltage within a limited range.

To select whether the full-scale reference is internally generated or externally provided, the digital input port VREFSEL should be set appropriately, low for internal or high for external. This pin also has an internal 18k Ω pull-up resistor. To use the internally generated reference, VREFSEL can be tied directly to AVSS, and to use an external reference, VREFSEL can be left unconnected.

Analog Input

The fully differential ADC input (INP/INN) connects to the sample and hold circuit. The ideal full-scale input voltage is 1.5V_{PP}, centered at the VCM voltage of 0.86V as shown in Figure 22.

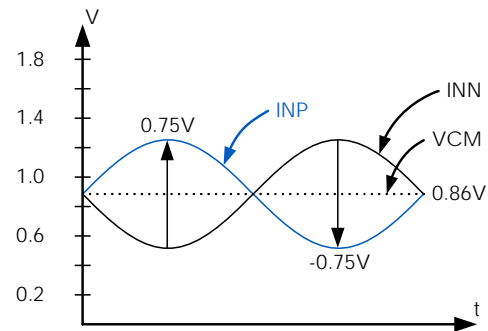

FIGURE 22. ANALOG INPUT RANGE

Best performance is obtained when the analog inputs are driven differentially in an AC-coupled configuration. The common-mode output voltage, VCM, should be used to properly bias each input as shown in Figures 23 and 24. An RF transformer will give the best noise and distortion performance for wideband and/or high intermediate frequency (IF) inputs. The recommended biasing is shown in Figures 23 and 24.

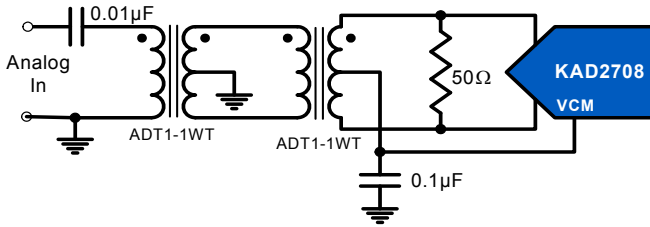

FIGURE 23. TRANSFORMER INPUT, GENERAL APPLICATION

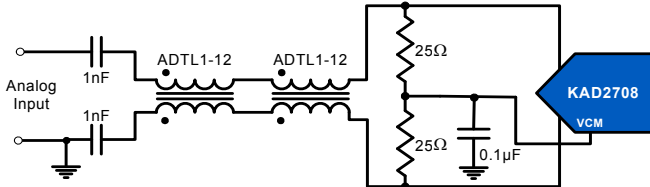

FIGURE 24. TRANSFORMER INPUT, HIGH IF APPLICATION

A back-to-back transformer scheme is used to improve common-mode rejection, which keeps the common-mode level of the input matched to V_{CM} . The value of the termination resistor should be determined based on the desired impedance.

The sample and hold circuit design uses a switched capacitor input stage, which creates current spikes when the sampling capacitance is reconnected to the input voltage. This creates a disturbance at the input which must settle before the next sampling point. Lower source impedance will result in faster settling and improved performance. Therefore a 1:1 transformer and low shunt resistance are recommended for optimal performance.

A differential amplifier can be used in applications that require DC coupling, at the expense of reduced dynamic performance. In this configuration the amplifier will typically reduce the achievable SNR and distortion performance. A typical differential amplifier configuration is shown in Figure 25.

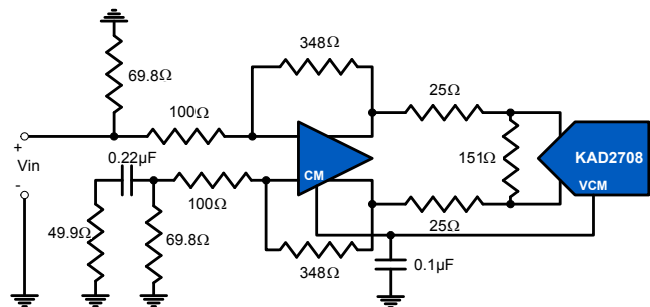

FIGURE 25. DIFFERENTIAL AMPLIFIER INPUT

Clock Input

The clock input circuit is a differential pair (see Figure 29). Driving these inputs with a high level (up to 1.8V_{PP} on each input) sine or square wave will provide the lowest jitter performance. The recommended drive circuit is shown in Figure 26. The clock can be driven single-ended, but this will reduce the edge rate and may impact SNR performance.

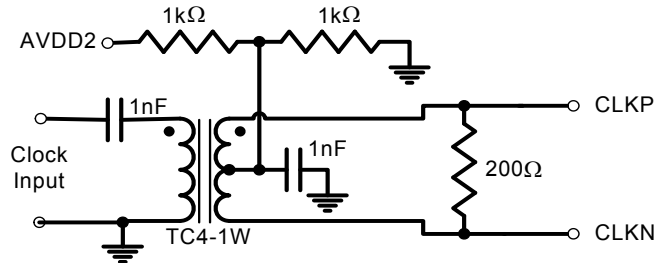

FIGURE 26. RECOMMENDED CLOCK DRIVE

Use of the clock divider is optional. The KAD2708C's ADC requires a clock with 50% duty cycle for optimum performance. If such a clock is not available, one option is to generate twice the desired sampling rate, then use the KAD2708C's divide-by-2 to generate a 50%-duty-cycle clock. This frequency divider uses the rising edge of the clock, so 50% clock duty cycle is assured. Table 2 describes the CLKDIV connection.

TABLE 2. CLKDIV PIN SETTINGS

CLKDIV PIN	DIVIDE RATIO
AVSS	2
AVDD	1

CLKDIV is internally pulled low, so a pull-up resistor or logic driver must be connected for undivided clock.

Jitter

In a sampled data system, clock jitter directly impacts the achievable SNR performance. The theoretical relationship between clock jitter and maximum SNR is shown in Equation 1 and is illustrated in Figure 27.

$$SNR = 20 \log_{10} \left(\frac{1}{2\pi f_{IN} t_j} \right) \tag{EQ. 1}$$

Where t_j is the RMS uncertainty in the sampling instant.

This relationship shows the SNR that would be achieved if clock jitter were the only non-ideal factor. In reality, achievable SNR is limited by internal factors such as differential nonlinearity, aperture jitter and thermal noise.

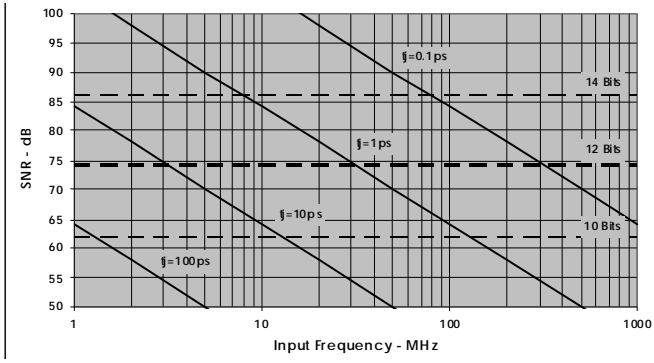

FIGURE 27. SNR vs CLOCK JITTER

Any internal aperture jitter combines with the input clock jitter, in a root-sum-square fashion since they are not statistically correlated, and this determines the total jitter in the system. The total jitter, combined with other noise sources, then determines the achievable SNR.

Digital Outputs

Data is output on a parallel bus with LVDS-compatible drivers.

The output format (Binary or Two's Complement) is selected via the 2SC pin as shown in Table 3.

TABLE 3. 2SC PIN SETTINGS

2SC PIN	MODE
AVSS	Two's Complement
AVDD	Binary

Equivalent Circuits

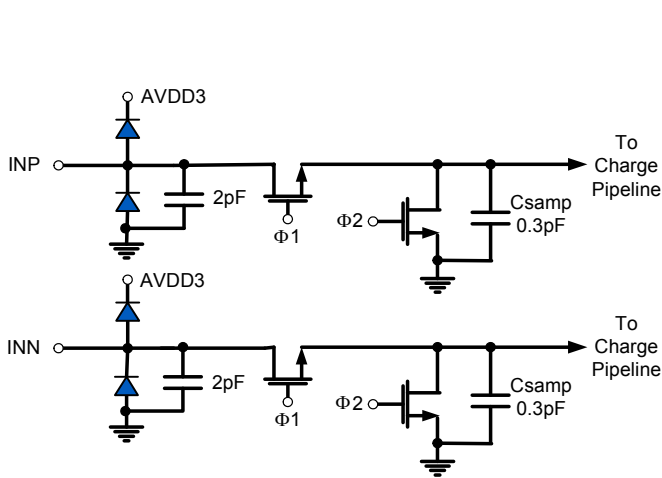

FIGURE 28. ANALOG INPUTS

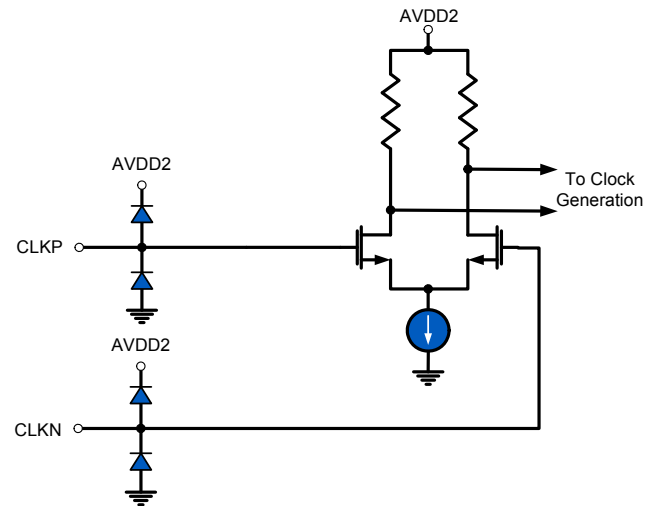

FIGURE 29. CLOCK INPUTS

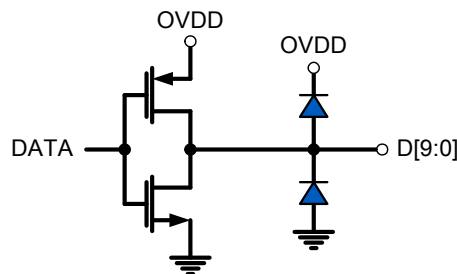

FIGURE 30. LVCMOS OUTPUT

Layout Considerations

Split Ground and Power Planes

Data converters operating at high sampling frequencies require extra care in PC board layout. Many complex board designs benefit from isolating the analog and digital sections. Analog supply and ground planes should be laid out under signal and clock inputs. Locate the digital planes under outputs and logic pins. Grounds should be joined under the chip.

Clock Input Considerations

Use matched transmission lines to the inputs for the analog input and clock signals. Locate transformers, drivers and terminations as close to the chip as possible.

Bypass and Filtering

Bulk capacitors should have low equivalent series resistance. Tantalum is a good choice. For best performance, keep ceramic bypass capacitors very close to device pins. Longer traces will increase inductance, resulting in diminished dynamic performance and accuracy. Make sure that connections to ground are direct and low impedance.

LVMOS Outputs

Output traces and connections must be designed for 50Ω characteristic impedance. Avoid crossing ground and power-plane breaks with signal traces.

Unused Inputs

The RST and 2SC inputs are internally pulled up, and can be left open-circuit if not used.

CLKDIV is internally pulled low, which divides the input clock by two.

VREFSEL is internally pulled up. It must be held low for internal reference, but can be left open for external reference.

Definitions

Analog Input Bandwidth is the analog input frequency at which the spectral output power at the fundamental frequency (as determined by FFT analysis) is reduced by 3dB from its full-scale low-frequency value. This is also referred to as Full Power Bandwidth.

Aperture Delay or Sampling Delay is the time required after the rise of the clock input for the sampling switch to open, at which time the signal is held for conversion.

Aperture Jitter is the RMS variation in aperture delay for a set of samples.

Clock Duty Cycle is the ratio of the time the clock wave is at logic high to the total time of one clock period.

Differential Non-Linearity (DNL) is the deviation of any code width from an ideal 1 LSB step.

Effective Number of Bits (ENOB) is an alternate method of specifying Signal to Noise-and-Distortion Ratio (SINAD). In dB, it is calculated as: $ENOB = (SINAD - 1.76)/6.02$.

Integral Non-Linearity (INL) is the deviation of each individual code from a line drawn from negative full-scale (1/2 LSB below the first code transition) through positive full-scale (1/2 LSB above the last code transition). The deviation of any given code from this line is measured from the center of that code.

Least Significant Bit (LSB) is the bit that has the smallest value or weight in a digital word. Its value in terms of input voltage is $VFS/(2^N - 1)$ where N is the resolution in bits.

Missing Codes are output codes that are skipped and will never appear at the ADC output. These codes cannot be reached with any input value.

Most Significant Bit (MSB) is the bit that has the largest value or weight. Its value in terms of input voltage is $VFS/2$.

Pipeline Delay is the number of clock cycles between the initiation of a conversion and the appearance at the output pins of the corresponding data.

Power Supply Rejection Ratio (PSRR) is the ratio of a change in power supply voltage to the input voltage necessary to negate the resultant change in output code.

Signal to Noise-and-Distortion (SINAD) is the ratio of the RMS signal amplitude to the RMS sum of all other spectral components below one half the clock frequency, including harmonics but excluding DC.

Signal-to-Noise Ratio (SNR) (without Harmonics) is the ratio of the RMS signal amplitude to the RMS sum of all other spectral components below one-half the sampling frequency, excluding harmonics and DC.

Spurious-Free-Dynamic Range (SFDR) is the ratio of the RMS signal amplitude to the RMS value of the peak spurious spectral component. The peak spurious spectral component may or may not be a harmonic.

Two-Tone SFDR is the ratio of the RMS value of either input tone to the RMS value of the peak spurious component. The peak spurious component may or may not be an IMD product.

© Copyright Intersil Americas LLC 2008-2011. All Rights Reserved.
All trademarks and registered trademarks are the property of their respective owners.

For additional products, see www.intersil.com/en/products.html

Intersil products are manufactured, assembled and tested utilizing ISO9001 quality systems as noted in the quality certifications found at www.intersil.com/en/support/qualandreliability.html

Intersil products are sold by description only. Intersil may modify the circuit design and/or specifications of products at any time without notice, provided that such modification does not, in Intersil's sole judgment, affect the form, fit or function of the product. Accordingly, the reader is cautioned to verify that datasheets are current before placing orders. Information furnished by Intersil is believed to be accurate and reliable. However, no responsibility is assumed by Intersil or its subsidiaries for its use; nor for any infringements of patents or other rights of third parties which may result from its use. No license is granted by implication or otherwise under any patent or patent rights of Intersil or its subsidiaries.

For information regarding Intersil Corporation and its products, see www.intersil.com

Package Outline Drawing

L68.10x10B

68 LEAD QUAD FLAT NO-LEAD PLASTIC PACKAGE

Rev 0, 11/08

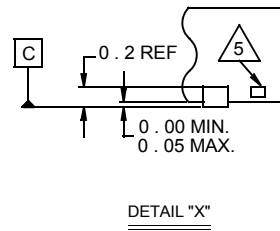
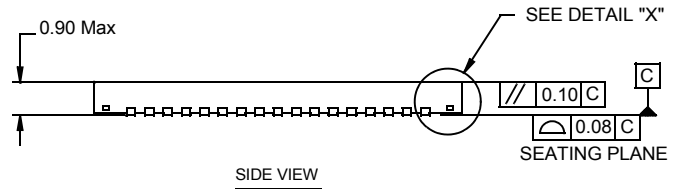
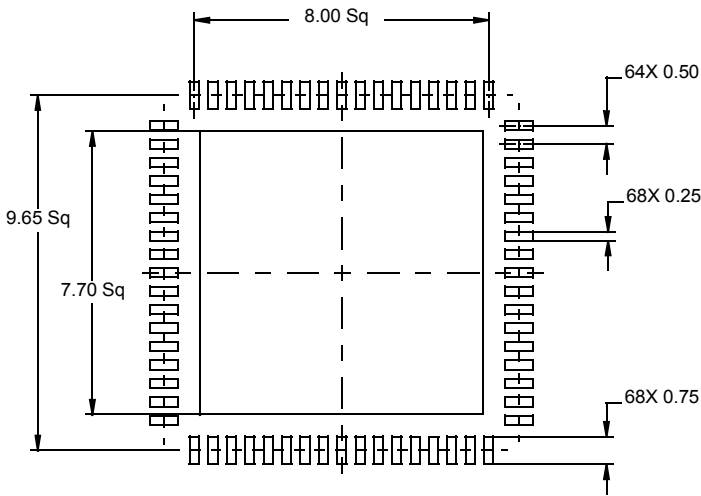
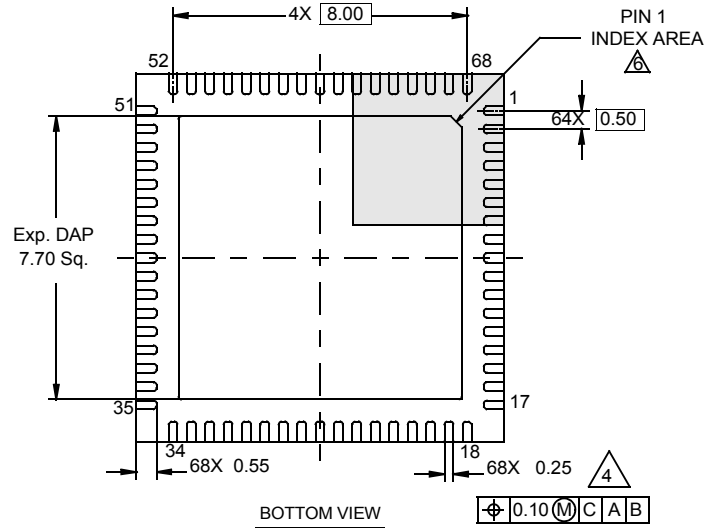
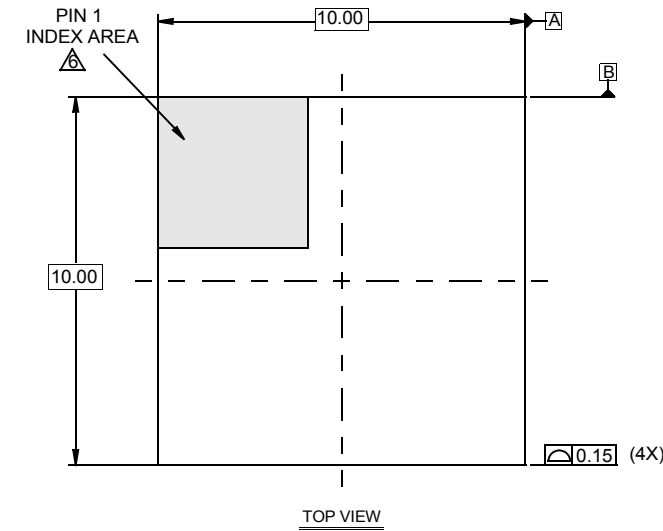

NOTES:

1. Dimensions are in millimeters.
Dimensions in () for Reference Only.
2. Dimensioning and tolerancing conform to AMSEY14.5m-1994.
3. Unless otherwise specified, tolerance : Decimal ± 0.05
4. Dimension b applies to the metallized terminal and is measured between 0.15mm and 0.30mm from the terminal tip.
5. Tiebar shown (if present) is a non-functional feature.
6. The configuration of the pin #1 identifier is optional, but must be located within the zone indicated. The pin #1 identifier may be either a mold or mark feature.

Компания «Life Electronics» занимается поставками электронных компонентов импортного и отечественного производства от производителей и со складов крупных дистрибьюторов Европы, Америки и Азии.

С конца 2013 года компания активно расширяет линейку поставок компонентов по направлению коаксиальный кабель, кварцевые генераторы и конденсаторы (керамические, пленочные, электролитические), за счёт заключения дистрибьюторских договоров

Мы предлагаем:

- Конкурентоспособные цены и скидки постоянным клиентам.
- Специальные условия для постоянных клиентов.
- Подбор аналогов.
- Поставку компонентов в любых объемах, удовлетворяющих вашим потребностям.
- Приемлемые сроки поставки, возможна ускоренная поставка.
- Доставку товара в любую точку России и стран СНГ.
- Комплексную поставку.
- Работу по проектам и поставку образцов.
- Формирование склада под заказчика.
- Сертификаты соответствия на поставляемую продукцию (по желанию клиента).
- Тестирование поставляемой продукции.
- Поставку компонентов, требующих военную и космическую приемку.
- Входной контроль качества.
- Наличие сертификата ISO.

В составе нашей компании организован Конструкторский отдел, призванный помогать разработчикам, и инженерам.

Конструкторский отдел помогает осуществить:

- Регистрацию проекта у производителя компонентов.
- Техническую поддержку проекта.
- Защиту от снятия компонента с производства.
- Оценку стоимости проекта по компонентам.
- Изготовление тестовой платы монтаж и пусконаладочные работы.



Тел: +7 (812) 336 43 04 (многоканальный)
Email: org@lifeelectronics.ru