



STEVAL-IFP019V1

Quad high-side smart-power solid-state relay demonstration board based on the VNI4140K-32

Data brief

Features

- Output current: 1 A per channel
- Shorted load protections
- Junction overtemperature protection
- Case overtemperature protection for thermal independence of the channels
- Thermal case shutdown non-simultaneous restart for the various channels
- Protection against loss of ground
- Current limitation
- Undervoltage shutdown
- Open drain diagnostic outputs
- 3.3 V CMOS/TTL compatible inputs
- Fast demagnetization of inductive loads
- Conforms to IEC 61131-2
- RoHS compliant

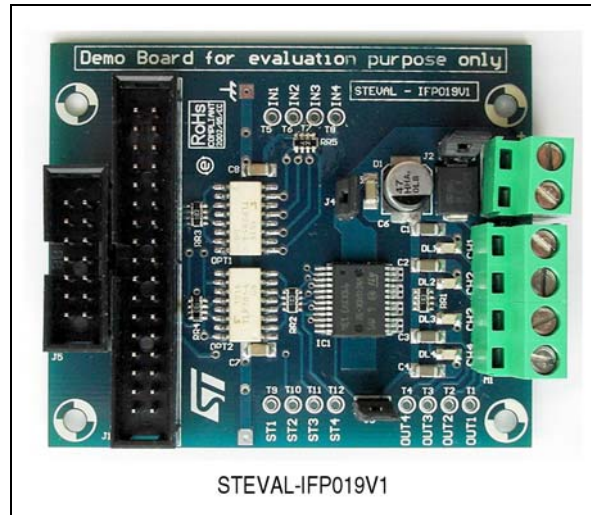

STEVAL-IFP019V1

Description

The STEVAL-IFP019V1 demonstration board shows the features of the VNI4140K-32 quad high-side smart-power solid-state relay.

The application offers robustness and complies with EMC industrial standards. It implements short-circuit/overload protection and also thermal management, achieving best-in-class MTBF values. The reference design is suitable for use in programmable logic controllers (PLCs) as well as to drive generic loads which require up to 1 A of nominal current (the typical current limitation is 1.1 - 2.6 A). Thanks to the very low $R_{DS(on)}$ (only 80 m Ω typical @ 25 °C per channel) the device allows very low power consumption during operation and for this reason it offers an ideal solution for IP65 / IP67 requirements. The VNI4140K-32 is compliant with IEC 61131-2 (international standard for programmable controllers).

1 Schematic circuit

Figure 1. Schematic circuit

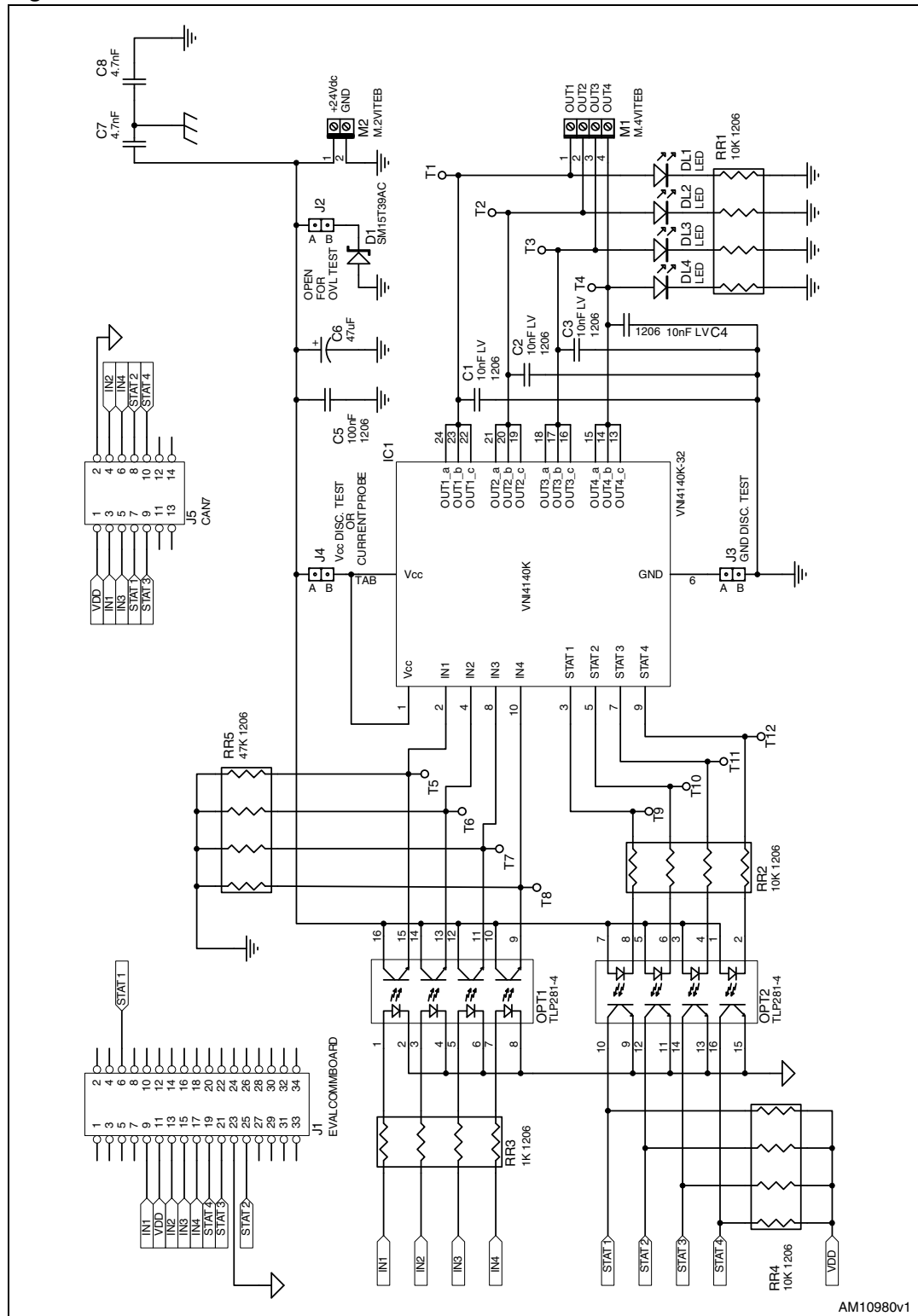

AM10980v1

2 Connectors

The STEVAL-IFP019V1 demonstration board uses input header connectors; one screw drives the four-channel output connector and one screw drives the two-channel supply connector.

Both input connectors, J5 and J1, provide the same bi-directional demonstration board signalization guaranteeing maximum compatibility with existing ST tools.

Figure 2. J1 connector pinout

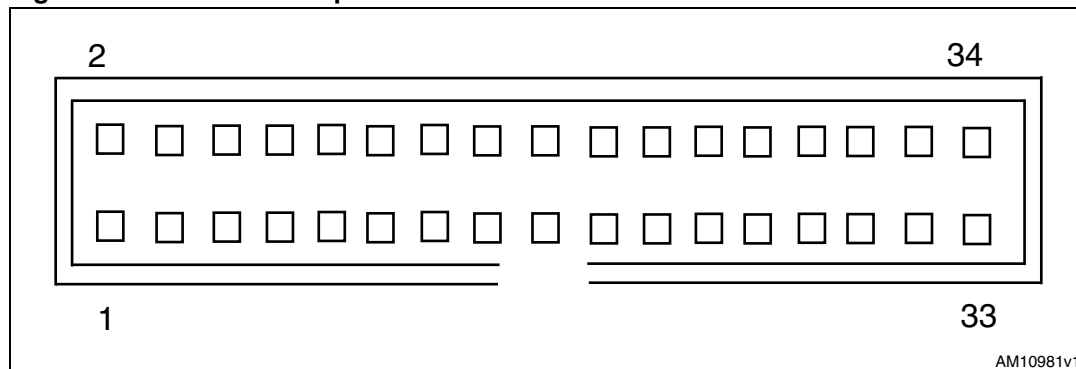

Figure 3. J5 connector pinout

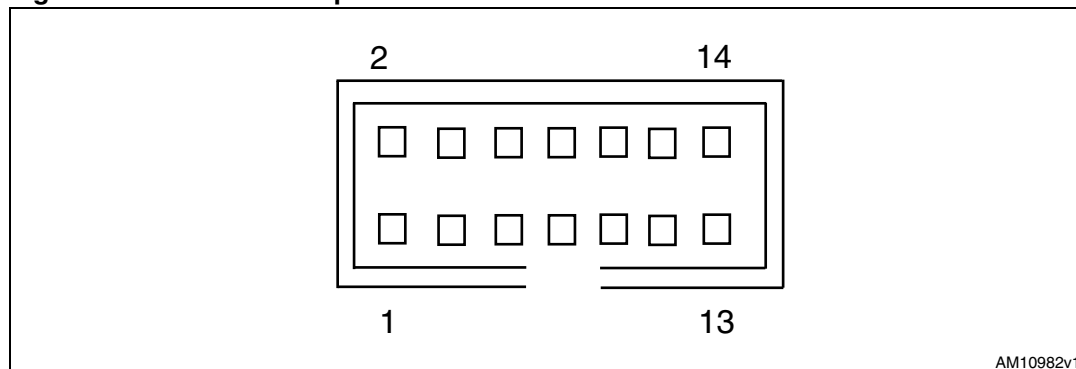

Table 1. Connector J1 and J5 pinout mapping

J1 pin number	J5 pin number	Signal	Type
11	1	V _{dd}	5 / 3.3 V supply voltage
23	2	GND	Signal ground
9	3	IN1	Input channel 1
13	4	IN2	Input channel 2
15	5	IN3	Input channel 3
17	6	IN4	Input channel 4
6	7	STAT1	Status channel 1
25	8	STAT2	Status channel 2
21	9	STAT3	Status channel 3
19	10	STAT4	Status channel 4

3 Revision history

Table 2. Document revision history

Date	Revision	Changes
19-Dec-2011	1	Initial release.

Please Read Carefully:

Information in this document is provided solely in connection with ST products. STMicroelectronics NV and its subsidiaries ("ST") reserve the right to make changes, corrections, modifications or improvements, to this document, and the products and services described herein at any time, without notice.

All ST products are sold pursuant to ST's terms and conditions of sale.

Purchasers are solely responsible for the choice, selection and use of the ST products and services described herein, and ST assumes no liability whatsoever relating to the choice, selection or use of the ST products and services described herein.

No license, express or implied, by estoppel or otherwise, to any intellectual property rights is granted under this document. If any part of this document refers to any third party products or services it shall not be deemed a license grant by ST for the use of such third party products or services, or any intellectual property contained therein or considered as a warranty covering the use in any manner whatsoever of such third party products or services or any intellectual property contained therein.

UNLESS OTHERWISE SET FORTH IN ST'S TERMS AND CONDITIONS OF SALE ST DISCLAIMS ANY EXPRESS OR IMPLIED WARRANTY WITH RESPECT TO THE USE AND/OR SALE OF ST PRODUCTS INCLUDING WITHOUT LIMITATION IMPLIED WARRANTIES OF MERCHANTABILITY, FITNESS FOR A PARTICULAR PURPOSE (AND THEIR EQUIVALENTS UNDER THE LAWS OF ANY JURISDICTION), OR INFRINGEMENT OF ANY PATENT, COPYRIGHT OR OTHER INTELLECTUAL PROPERTY RIGHT.

UNLESS EXPRESSLY APPROVED IN WRITING BY TWO AUTHORIZED ST REPRESENTATIVES, ST PRODUCTS ARE NOT RECOMMENDED, AUTHORIZED OR WARRANTED FOR USE IN MILITARY, AIR CRAFT, SPACE, LIFE SAVING, OR LIFE SUSTAINING APPLICATIONS, NOR IN PRODUCTS OR SYSTEMS WHERE FAILURE OR MALFUNCTION MAY RESULT IN PERSONAL INJURY, DEATH, OR SEVERE PROPERTY OR ENVIRONMENTAL DAMAGE. ST PRODUCTS WHICH ARE NOT SPECIFIED AS "AUTOMOTIVE GRADE" MAY ONLY BE USED IN AUTOMOTIVE APPLICATIONS AT USER'S OWN RISK.

Resale of ST products with provisions different from the statements and/or technical features set forth in this document shall immediately void any warranty granted by ST for the ST product or service described herein and shall not create or extend in any manner whatsoever, any liability of ST.

ST and the ST logo are trademarks or registered trademarks of ST in various countries.

Information in this document supersedes and replaces all information previously supplied.

The ST logo is a registered trademark of STMicroelectronics. All other names are the property of their respective owners.

© 2011 STMicroelectronics - All rights reserved

STMicroelectronics group of companies

Australia - Belgium - Brazil - Canada - China - Czech Republic - Finland - France - Germany - Hong Kong - India - Israel - Italy - Japan - Malaysia - Malta - Morocco - Philippines - Singapore - Spain - Sweden - Switzerland - United Kingdom - United States of America

www.st.com

Компания «Life Electronics» занимается поставками электронных компонентов импортного и отечественного производства от производителей и со складов крупных дистрибьюторов Европы, Америки и Азии.

С конца 2013 года компания активно расширяет линейку поставок компонентов по направлению коаксиальный кабель, кварцевые генераторы и конденсаторы (керамические, пленочные, электролитические), за счёт заключения дистрибьюторских договоров

Мы предлагаем:

- Конкурентоспособные цены и скидки постоянным клиентам.
- Специальные условия для постоянных клиентов.
- Подбор аналогов.
- Поставку компонентов в любых объемах, удовлетворяющих вашим потребностям.
- Приемлемые сроки поставки, возможна ускоренная поставка.
- Доставку товара в любую точку России и стран СНГ.
- Комплексную поставку.
- Работу по проектам и поставку образцов.
- Формирование склада под заказчика.
- Сертификаты соответствия на поставляемую продукцию (по желанию клиента).
- Тестирование поставляемой продукции.
- Поставку компонентов, требующих военную и космическую приемку.
- Входной контроль качества.
- Наличие сертификата ISO.

В составе нашей компании организован Конструкторский отдел, призванный помогать разработчикам, и инженерам.

Конструкторский отдел помогает осуществить:

- Регистрацию проекта у производителя компонентов.
- Техническую поддержку проекта.
- Защиту от снятия компонента с производства.
- Оценку стоимости проекта по компонентам.
- Изготовление тестовой платы монтаж и пусконаладочные работы.



Тел: +7 (812) 336 43 04 (многоканальный)
Email: org@lifeelectronics.ru