

PROTECTION PRODUCTS - MicroClamp™

Description

The μClamp™ series of TVS arrays are designed to protect sensitive electronics from damage or latch-up due to ESD. They are designed for use in applications where board space is at a premium. Each device requires less than 2.9mm² of PCB area and will protect up to five lines. They are bidirectional devices and may be used on lines where the signal polarities swing above and below ground.

TVS diodes are solid-state devices designed specifically for transient suppression. They feature large cross-sectional area junctions for conducting high transient currents. They offer desirable characteristics for board level protection including fast response time, low operating and clamping voltage, and no device degradation.

These devices may be used to meet the immunity requirements of IEC 61000-4-2, level 4. The small SC89 package makes them ideal for use in portable electronics such as cell phones, PDAs, notebook computers, and digital cameras.

Features

- ◆ Transient protection for data lines to **IEC 61000-4-2 (ESD) ±15kV (air), ±8kV (contact) IEC 61000-4-4 (EFT) 40A (5/50ns)**
- ◆ Protects five bidirectional I/O lines
- ◆ Ultra-small SC-89 package (**1.7 x 1.7 x 0.6mm**) requires less than 2.9mm² of PCB area
- ◆ Working voltage: 5V
- ◆ Low leakage current
- ◆ Low operating and clamping voltages
- ◆ Solid-state silicon-avalanche technology

Mechanical Characteristics

- ◆ SC-89 (SOT-666) package
- ◆ RoHS / WEEE Compliant
- ◆ Molding compound flammability rating: UL 94V-0
- ◆ Marking : Marking Code and pin 1 indicator
- ◆ Weight: 2.9mg (typical)
- ◆ Packaging : Tape and Reel per EIA 481

Applications

- ◆ Cellular Handsets and Accessories
- ◆ Cordless Phones
- ◆ Notebooks and Handhelds
- ◆ Portable Instrumentation
- ◆ Digital Cameras
- ◆ Peripherals
- ◆ MP3 Players

Dimensions

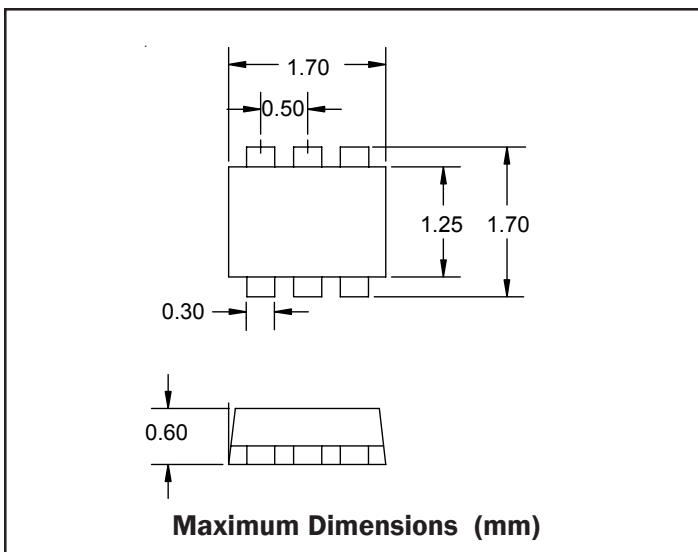

Schematic & PIN Configuration

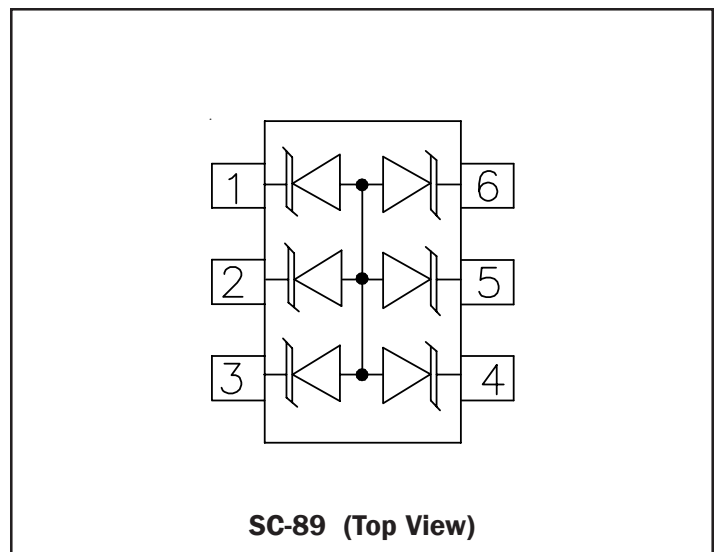

PROTECTION PRODUCTS
Absolute Maximum Rating

Rating	Symbol	Value	Units
Peak Pulse Power (tp = 8/20μs)	P_{pk}	100	Watts
Maximum Peak Pulse Current (tp = 8/20μs)	I_{pp}	7	Amps
ESD per IEC 61000-4-2 (Air) ESD per IEC 61000-4-2 (Contact)	V_{pp}	+/- 20 +/- 12	kV
Lead Soldering Temperature	T_L	260 (10 sec.)	°C
Operating Temperature	T_J	-55 to +125	°C
Storage Temperature	T_{STG}	-55 to +150	°C

Electrical Characteristics (T=25°C)

Parameter	Symbol	Conditions	Minimum	Typical	Maximum	Units
Reverse Stand-Off Voltage	V_{RWM}				5	V
Reverse Breakdown Voltage	V_{BR}	$I_t = 1mA$	6	7.8	9	V
Reverse Leakage Current	I_R	$V_{RWM} = 5V, T=25°C$		0.100	1	μA
Reverse Leakage Current	I_R	$V_{RWM} = 3V, T=25°C$		0.050	0.500	μA
Clamping Voltage	V_C	$I_{pp} = 1A, t_p = 8/20μs$			9	V
Clamping Voltage	V_C	$I_{pp} = 7A, t_p = 8/20μs$			12	V
Junction Capacitance	C_j	Between I/O Pins and Gnd $V_R = 0V, f = 1MHz$		30	40	pF

PROTECTION PRODUCTS

Typical Characteristics

Non-Repetitive Peak Pulse Power vs. Pulse Time

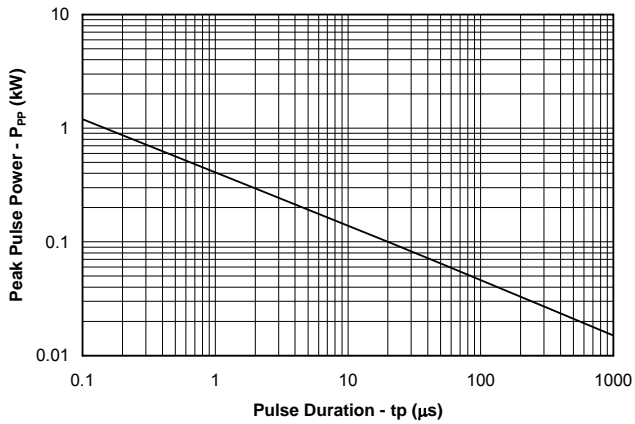

Power Derating Curve

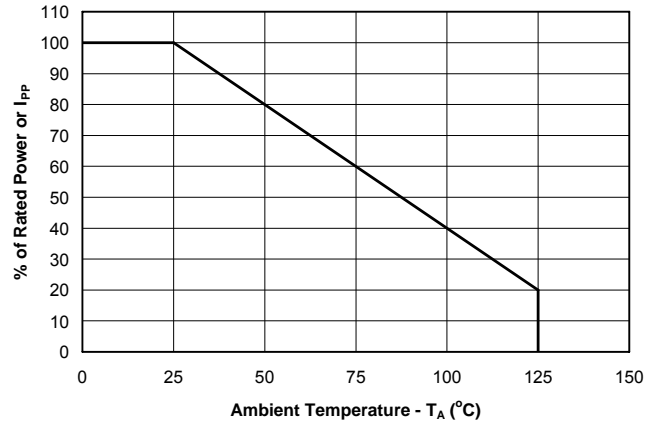

Clamping Voltage vs. Peak Pulse Current

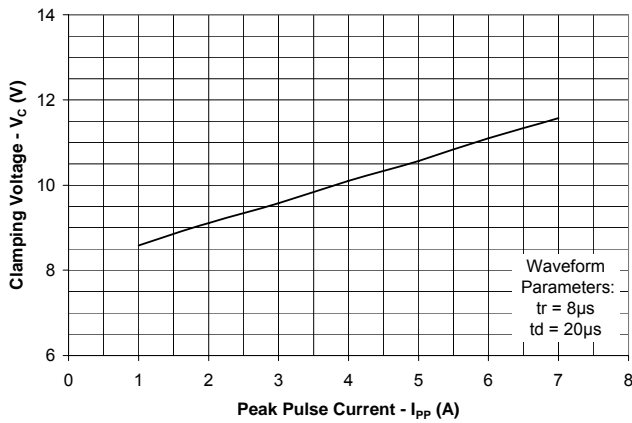

Junction Capacitance vs. Reverse Voltage

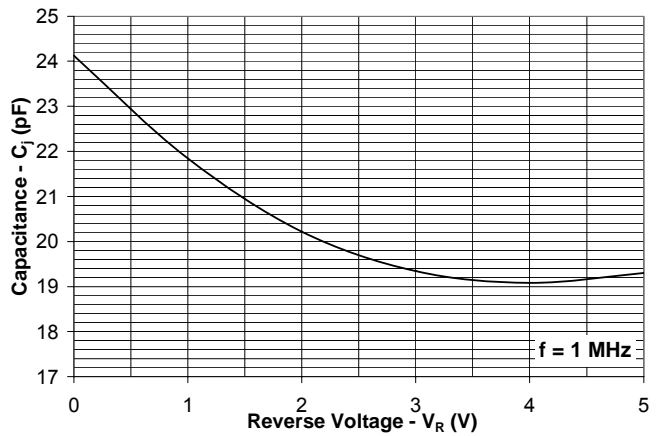

Insertion Loss S21

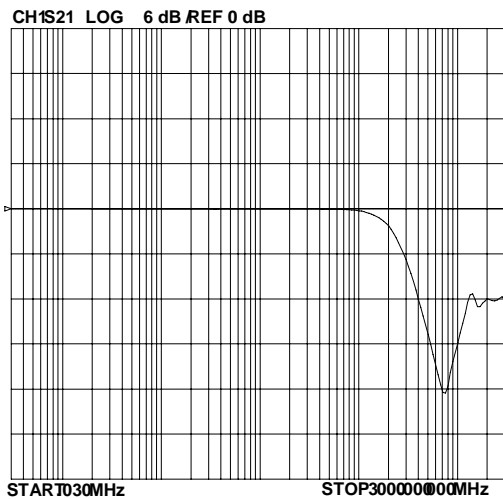

PROTECTION PRODUCTS

Typical Characteristics (Con't.)

**ESD Clamping
(+8kV Contact per IEC 61000-4-2)**

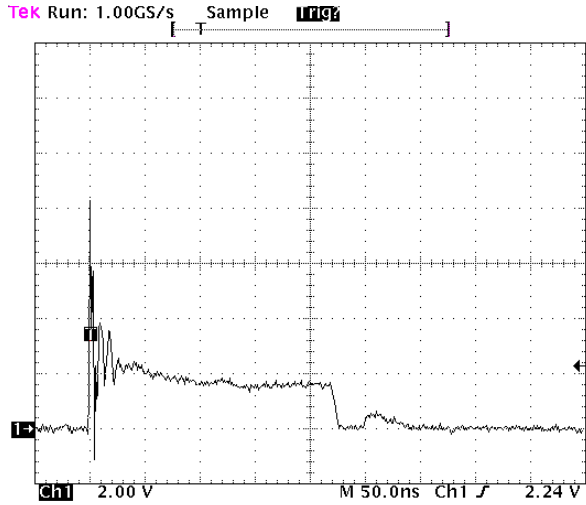

**ESD Clamping
(-8kV Contact per IEC 61000-4-2)**

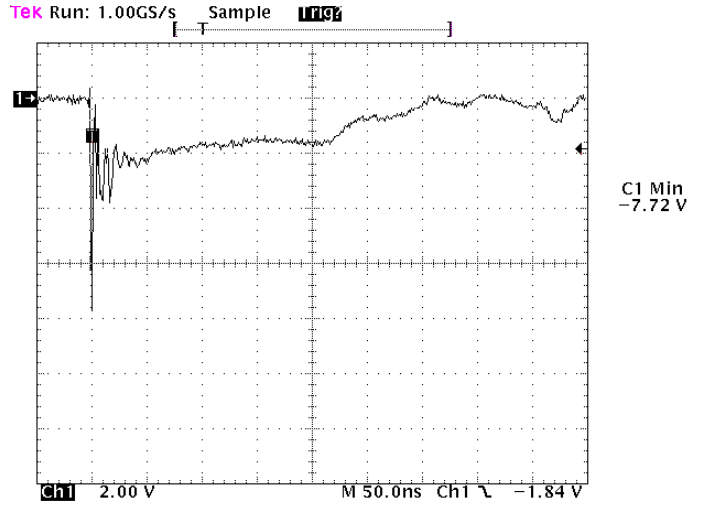

PROTECTION PRODUCTS

Applications Information

Device Connection for Protection of Five Data Lines

These devices are designed to protect up to five biidirectional data lines. The device is connected as follows:

1. Bidirectional protection of five I/O lines is achieved by connecting pins 1, 3, 4, 5, and 6 to the data lines. Pin 2 is connected to ground. The ground connection should be made directly to the ground plane for best results. The path length is kept as short as possible to reduce the effects of parasitic inductance in the board traces.

Circuit Board Layout Recommendations for Suppression of ESD.

Good circuit board layout is critical for the suppression of ESD induced transients. The following guidelines are recommended:

- Place the TVS near the input terminals or connectors to restrict transient coupling.
- Minimize the path length between the TVS and the protected line.
- Minimize all conductive loops including power and ground loops.
- The ESD transient return path to ground should be kept as short as possible.
- Never run critical signals near board edges.
- Use ground planes whenever possible.

Circuit Diagram

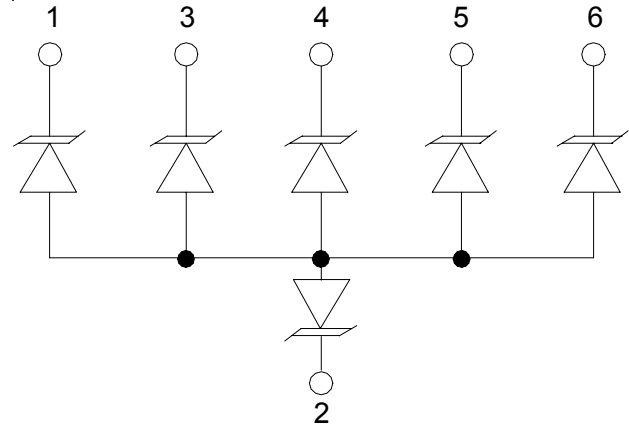

Protection of Five Bidirectional Lines

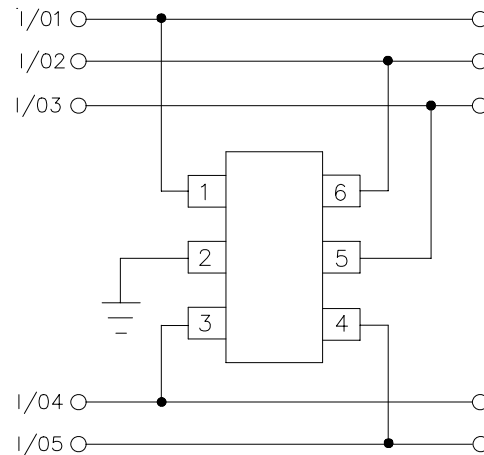

PROTECTION PRODUCTS

Typical Applications

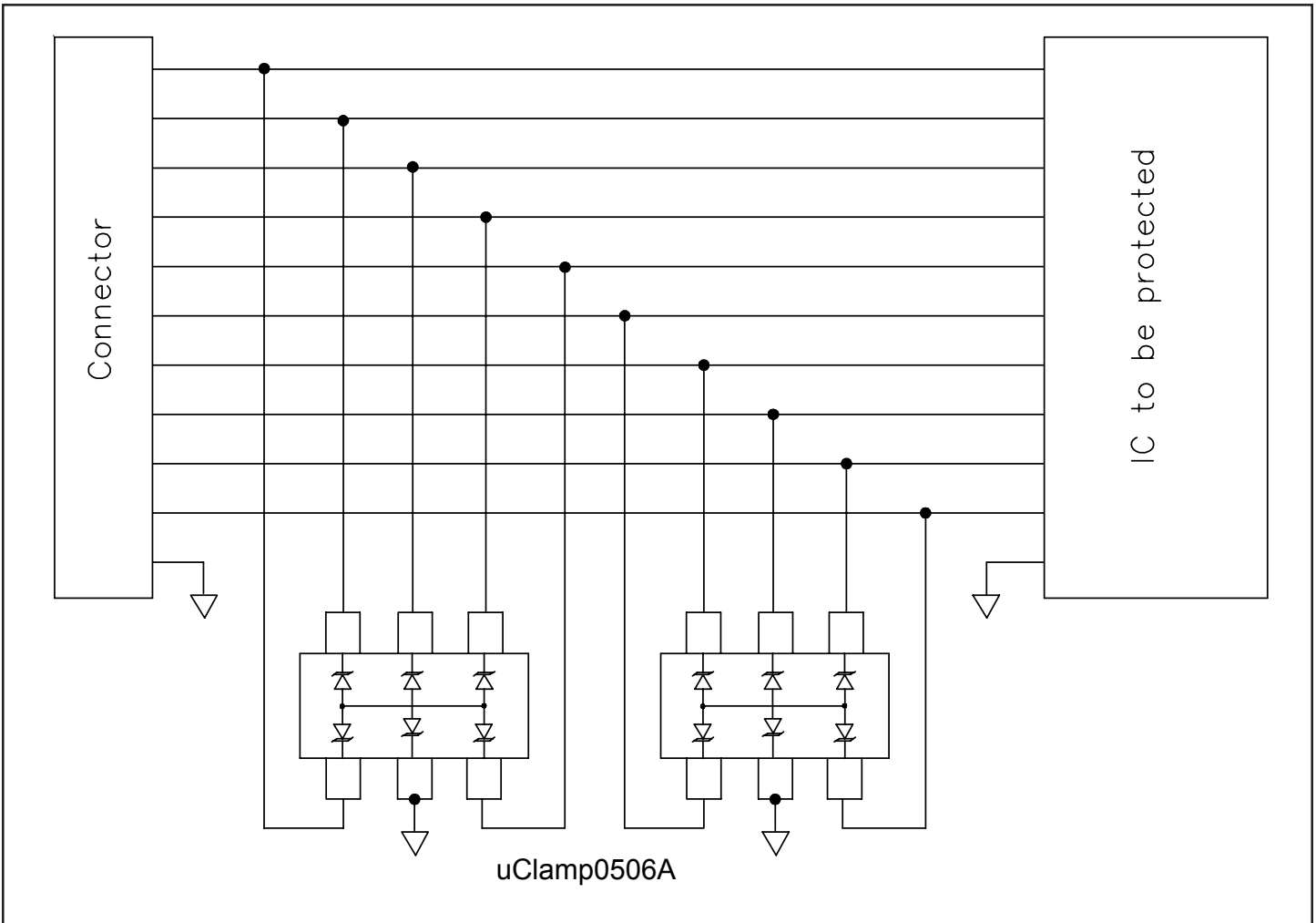

PROTECTION PRODUCTS

Outline Drawing - SC-89

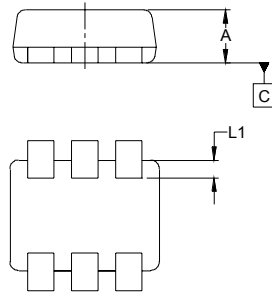
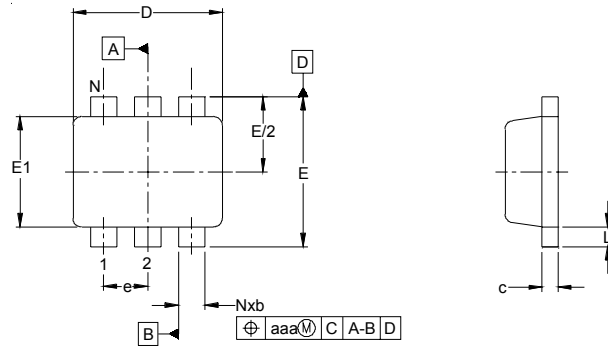

DIM	INCHES			MILLIMETERS		
	MIN	NOM	MAX	MIN	NOM	MAX
A	.019	-	.024	0.50	-	0.60
b	.005	-	.012	0.15	-	0.30
c	.003	-	.007	0.10	-	0.18
D	.059	.063	.067	1.50	1.60	1.70
E	.061	.063	.067	1.55	1.60	1.70
E1	.043	.047	.049	1.10	1.20	1.25
e	.020 BSC			0.50 BSC		
L	.003	.008	.012	0.10	0.20	0.30
L1	.003	.006	.008	0.10	0.15	0.20
N	6			6		
aaa	.004			0.10		

NOTES:

1. CONTROLLING DIMENSIONS ARE IN MILLIMETERS (ANGLES IN DEGREES).
2. DIMENSIONS "E1" AND "D" DO NOT INCLUDE MOLD FLASH, PROTRUSIONS OR GATE BURRS.

Land Pattern - SC89

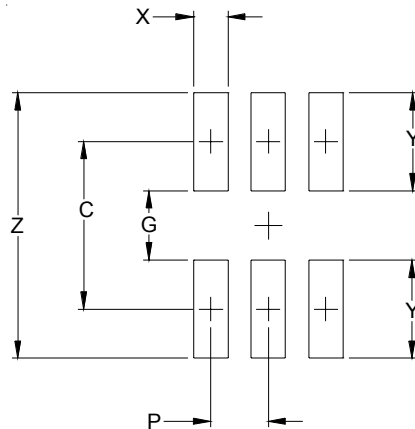

DIM	DIMENSIONS	
	INCHES	MILLIMETERS
C	(.057)	(1.45)
P	.020	0.50
G	.024	0.60
X	.012	0.30
Y	.033	0.85
Z	.090	2.30

NOTES:

1. THIS LAND PATTERN IS FOR REFERENCE PURPOSES ONLY CONSULT YOUR MANUFACTURING GROUP TO ENSURE YOUR COMPANY'S MANUFACTURING GUIDELINES ARE MET.

PROTECTION PRODUCTS

Marking Code

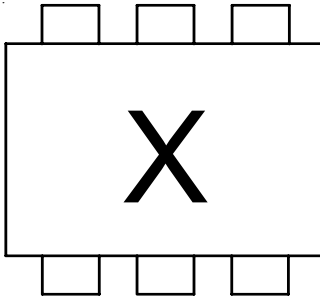

Ordering Information

Part Number	Working Voltage	Device Marking	Qty per Reel	Reel Size
uClamp0506A.TCT	5V	X	3,000	7 Inch

MicroClamp, uClamp and μ Clamp are trademarks of Semtech Corporation

Note:

- (1) Device is symmetrical so there is no pin 1 identifier
- (2) Lead finish is matte tin

Tape and Reel Specification

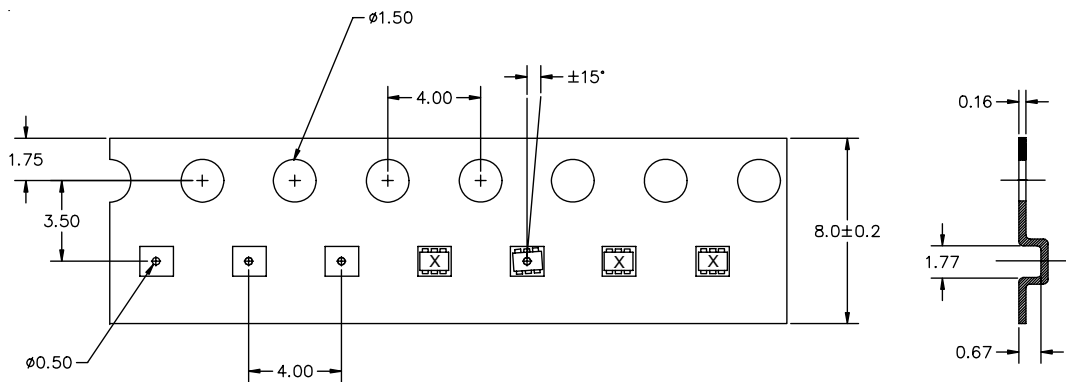

☐ DIMENSIONS ARE IN MILLIMETERS.

☐ SAME AS 3M US046041.

Tape Specifications and Device Orientation

Contact Information

Semtech Corporation
 Protection Products Division
 200 Flynn Rd., Camarillo, CA 93012
 Phone: (805)498-2111 FAX (805)498-3804

Компания «Life Electronics» занимается поставками электронных компонентов импортного и отечественного производства от производителей и со складов крупных дистрибьюторов Европы, Америки и Азии.

С конца 2013 года компания активно расширяет линейку поставок компонентов по направлению коаксиальный кабель, кварцевые генераторы и конденсаторы (керамические, пленочные, электролитические), за счёт заключения дистрибьюторских договоров

Мы предлагаем:

- Конкурентоспособные цены и скидки постоянным клиентам.
- Специальные условия для постоянных клиентов.
- Подбор аналогов.
- Поставку компонентов в любых объемах, удовлетворяющих вашим потребностям.
- Приемлемые сроки поставки, возможна ускоренная поставка.
- Доставку товара в любую точку России и стран СНГ.
- Комплексную поставку.
- Работу по проектам и поставку образцов.
- Формирование склада под заказчика.
- Сертификаты соответствия на поставляемую продукцию (по желанию клиента).
- Тестирование поставляемой продукции.
- Поставку компонентов, требующих военную и космическую приемку.
- Входной контроль качества.
- Наличие сертификата ISO.

В составе нашей компании организован Конструкторский отдел, призванный помогать разработчикам, и инженерам.

Конструкторский отдел помогает осуществить:

- Регистрацию проекта у производителя компонентов.
- Техническую поддержку проекта.
- Защиту от снятия компонента с производства.
- Оценку стоимости проекта по компонентам.
- Изготовление тестовой платы монтаж и пусконаладочные работы.



Тел: +7 (812) 336 43 04 (многоканальный)
Email: org@lifeelectronics.ru