

2-line IPAD™, EMI filter and ESD protection

Datasheet - production data

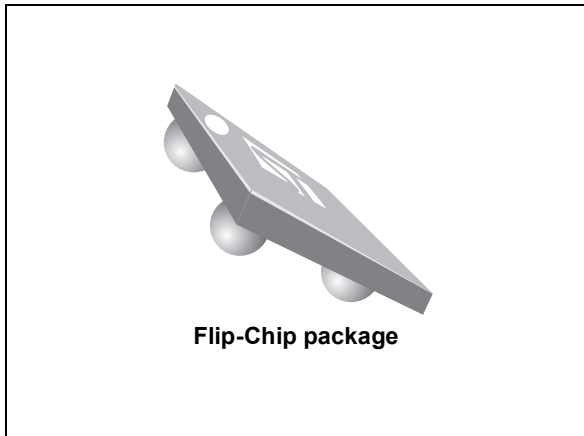
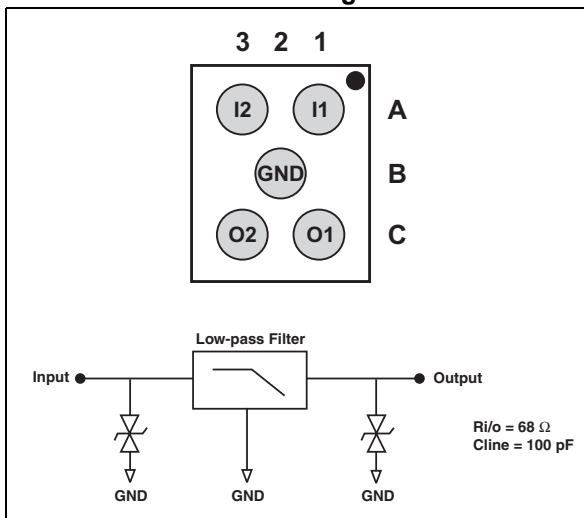

Figure 1. Pin configuration (bump side) and basic cell configuration



Features

- EMI symmetrical (I/O) low-pass filter
- High efficiency in EMI filtering
- Very low PCB space consuming:
1.07 mm x 1.47 mm
- Very thin package: 0.65 mm
- High efficiency in ESD suppression

- High reliability offered by monolithic integration
- High reducing of parasitic elements through integration and wafer level packaging

Complies with the following standards:

- IEC 61000-4-2 level 4, on input pins
 - 15 kV (air discharge)
 - 8 kV (contact discharge)
- IEC 61000-4-2 Level 1, on output pins
 - 2 kV (air discharge)
 - 2 kV (contact discharge)
- MIL STD 883E - Method 3015-6 Class 3

Application

- Mobile phones (differential microphone filtering and ESD protection).

Description

The EMIF02-MIC03F2 is a highly integrated device designed to suppress EMI/RFI noise in all systems subjected to electromagnetic interferences. The EMIF02 Flip-Chip packaging means the package size is equal to the die size.

This filter includes an ESD protection circuitry which prevents damage to the application when subjected to ESD surges up 15 kV.

TM: IPAD is a trademark of STMicroelectronics.

1 Electrical characteristics

Table 1. Absolute maximum ratings ($T_{AMB} = 25\text{ }^{\circ}\text{C}$)

Symbol	Parameter	Value	Unit
Tj	Maximum junction temperature	125	$^{\circ}\text{C}$
Top	Operating temperature range	-40 to +85	$^{\circ}\text{C}$
Tstg	Storage temperature range	-55 to +150	$^{\circ}\text{C}$

Table 2. Electrical characteristics ($T_{amb} = 25\text{ }^{\circ}\text{C}$)

Symbol	Parameters
V_{BR}	Breakdown voltage
I_{RM}	Leakage current @ V_{RM}
V_{RM}	Stand-off voltage
V_{CL}	Clamping voltage
R_d	Dynamic impedance
I_{PP}	Peak pulse current
$R_{I/O}$	Series resistance between Input & Output
C_{line}	Input capacitance per line

Table 3.

Symbol	Test condition	Min	Typ	Max	Unit
V_{BR}	$I_R = 1\text{ mA}$	6	8		V
I_{RM}	$V_{RM} = 3\text{ V per line}$			500	nA
$R_{I/O}$	Tolerance $\pm 20\%$		68		Ω
C_{line}	$V_R = 0\text{ V}$		100		pF

Figure 2. Attenuation simulation with 1 kΩ input and 10 kΩ output

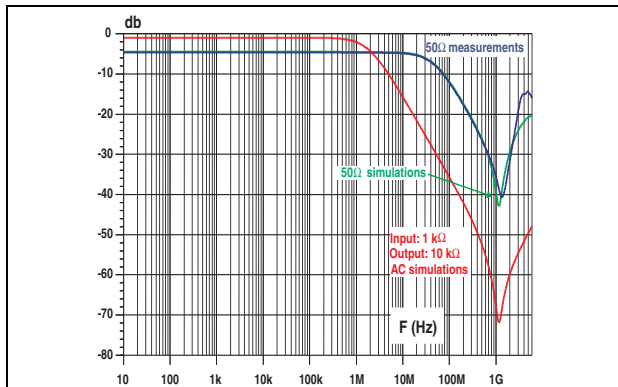

Figure 3. Analog crosstalk measurements

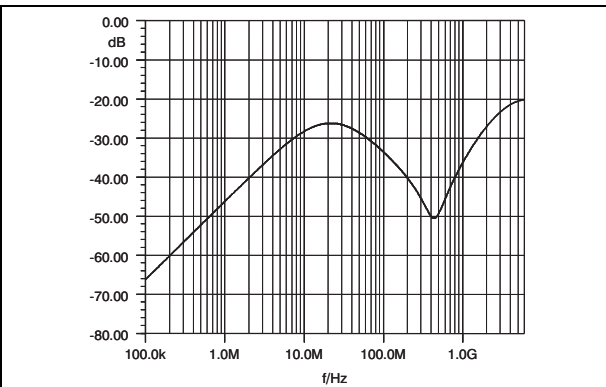

Figure 4. ESD response to IEC61000-4-2 (+15kV air discharge) on one input V(in) and one output V(out)

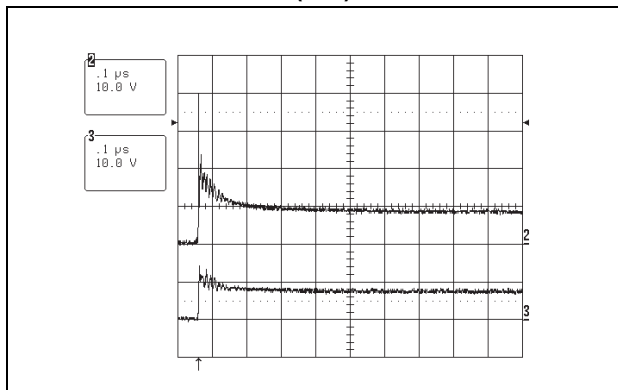

Figure 5. ESD response to IEC61000-4-2 (-15kV air discharge) on one input V(in) and one output V(out)

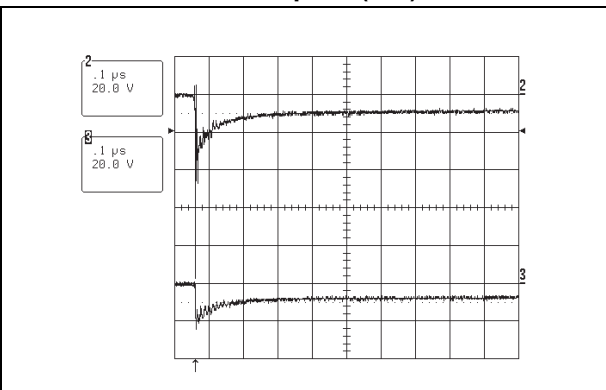

Figure 6. Line capacitance versus applied voltage.

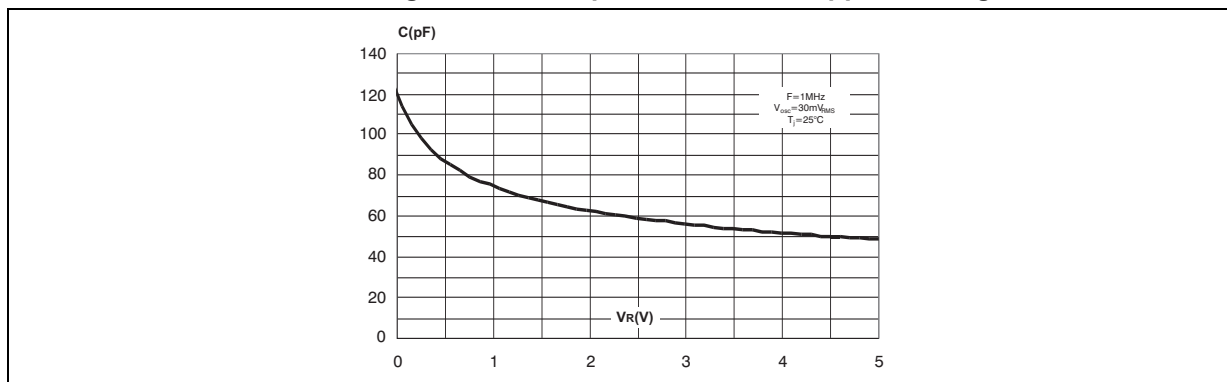

Figure 7. Aplac mode

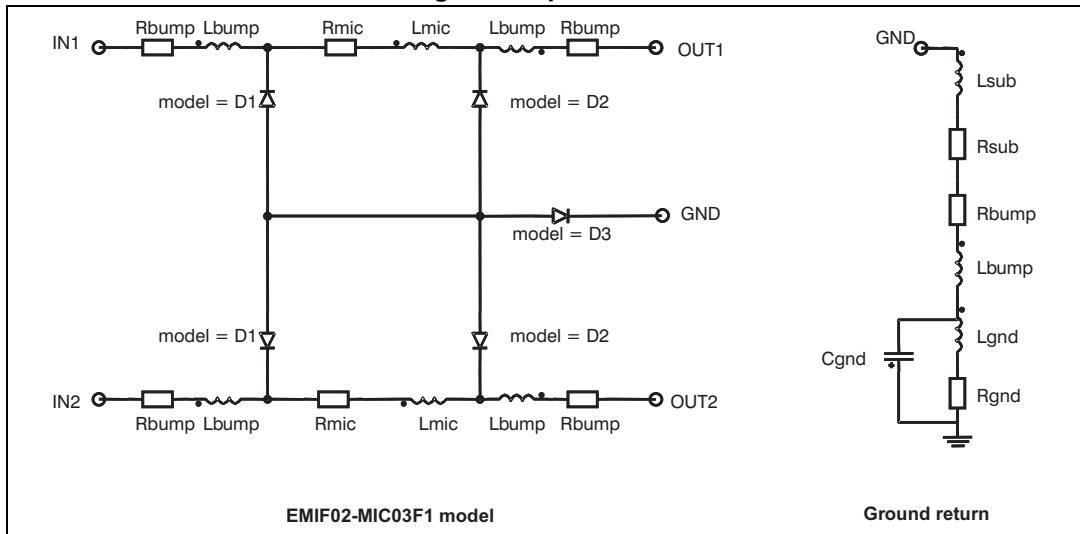
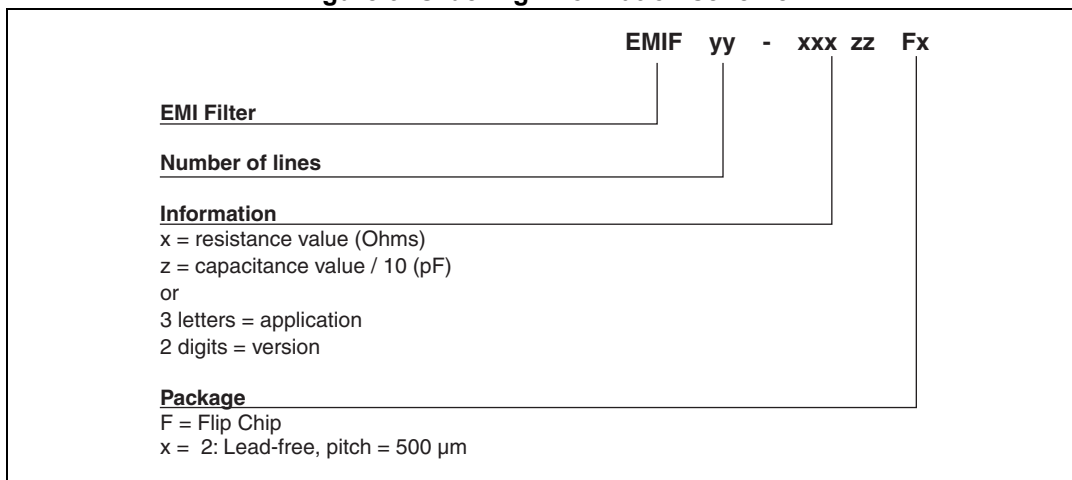

Figure 8. Aplac parameters

Model D1	Model D3	Model D2	aplacvar Rmic 68
CJO=Cdiode1	CJO=Cdiode3	CJO=Cdiode2	aplacvar Lmic 10p
BV=7	BV=7	BV=7	aplacvar Cdiode1 100pF
IBV=1u	IBV=1u	IBV=1u	aplacvar Cdiode2 3.6pF
IKF=1000	IKF=1000	IKF=1000	aplacvar Cdiode3
IS=10f	IS=10f	IS=10f	1.17nF
ISR=100p	ISR=100p	ISR=100p	aplacvar Lbump 50pH
N=1	N=1	N=1	aplacvar Rbump 20m
M=0.3333	M=0.3333	M=0.3333	aplacvar Rsub 0.5m
RS=0.7	RS=0.12	RS=0.3	aplacvar Rgnd 10m
VJ=0.6	VJ=0.6	VJ=0.6	aplacvar Lgnd 50pH
TT=50n	TT=50n	TT=50n	aplacvar Cgnd 0.15pF
			aplacvar Lsub 10pH

2 Ordering information scheme

Figure 9. Ordering information scheme



3 Package information

In order to meet environmental requirements, ST offers these devices in different grades of ECOPACK® packages, depending on their level of environmental compliance. ECOPACK® specifications, grade definitions and product status are available at: www.st.com. ECOPACK® is an ST trademark.

Figure 10. Flip Chip dimensions

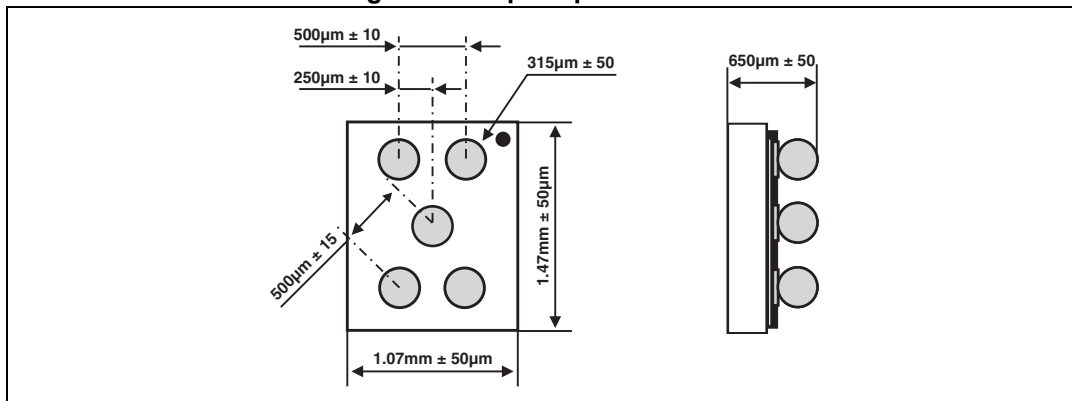

Figure 11. Footprint

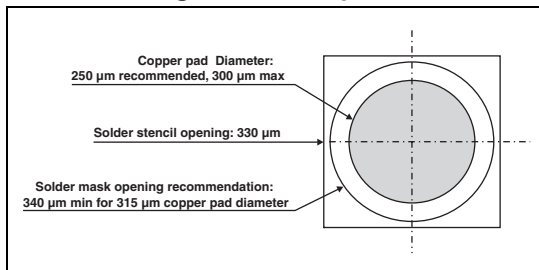

Figure 12. Marking

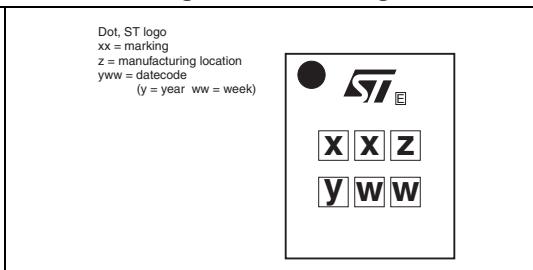
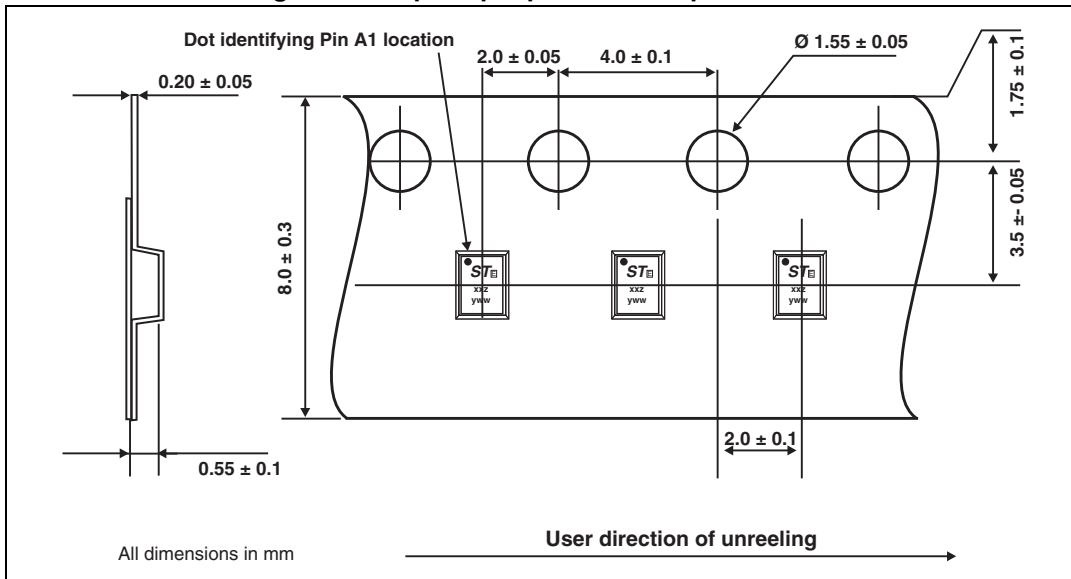

Figure 13. Flip Chip tape and reel specification



4 Ordering information

Table 4. Ordering information

Order code	Marking	Package	Weight	Base qty	Delivery mode
EMIF02-MIC03F2	FW	Flip Chip	2.1 mg	5000	Tape and reel (7")

Note: More packing information is available in the applications note:
 AN1235: "Flip Chip: package description and recommendations for use"
 AN 1751: "EMI filters: Recommendations and measurements"

5 Revision history

Table 5. Document revision history

Date	Revision	Changes
14-Oct-2006	1	Initial release
31-Mar-2014	2	Reformatted to current standards. Added ECOPACK statement. Updated Figure 2 and Figure 13 .
18/07/2014	3	Updated typo error on Features .

IMPORTANT NOTICE – PLEASE READ CAREFULLY

STMicroelectronics NV and its subsidiaries (“ST”) reserve the right to make changes, corrections, enhancements, modifications, and improvements to ST products and/or to this document at any time without notice. Purchasers should obtain the latest relevant information on ST products before placing orders. ST products are sold pursuant to ST’s terms and conditions of sale in place at the time of order acknowledgement.

Purchasers are solely responsible for the choice, selection, and use of ST products and ST assumes no liability for application assistance or the design of Purchasers’ products.

No license, express or implied, to any intellectual property right is granted by ST herein.

Resale of ST products with provisions different from the information set forth herein shall void any warranty granted by ST for such product.

ST and the ST logo are trademarks of ST. All other product or service names are the property of their respective owners.

Information in this document supersedes and replaces information previously supplied in any prior versions of this document.

© 2014 STMicroelectronics – All rights reserved

Компания «Life Electronics» занимается поставками электронных компонентов импортного и отечественного производства от производителей и со складов крупных дистрибьюторов Европы, Америки и Азии.

С конца 2013 года компания активно расширяет линейку поставок компонентов по направлению коаксиальный кабель, кварцевые генераторы и конденсаторы (керамические, пленочные, электролитические), за счёт заключения дистрибьюторских договоров

Мы предлагаем:

- Конкурентоспособные цены и скидки постоянным клиентам.
- Специальные условия для постоянных клиентов.
- Подбор аналогов.
- Поставку компонентов в любых объемах, удовлетворяющих вашим потребностям.
- Приемлемые сроки поставки, возможна ускоренная поставка.
- Доставку товара в любую точку России и стран СНГ.
- Комплексную поставку.
- Работу по проектам и поставку образцов.
- Формирование склада под заказчика.
- Сертификаты соответствия на поставляемую продукцию (по желанию клиента).
- Тестирование поставляемой продукции.
- Поставку компонентов, требующих военную и космическую приемку.
- Входной контроль качества.
- Наличие сертификата ISO.

В составе нашей компании организован Конструкторский отдел, призванный помогать разработчикам, и инженерам.

Конструкторский отдел помогает осуществить:

- Регистрацию проекта у производителя компонентов.
- Техническую поддержку проекта.
- Защиту от снятия компонента с производства.
- Оценку стоимости проекта по компонентам.
- Изготовление тестовой платы монтаж и пусконаладочные работы.



Тел: +7 (812) 336 43 04 (многоканальный)
Email: org@lifeelectronics.ru