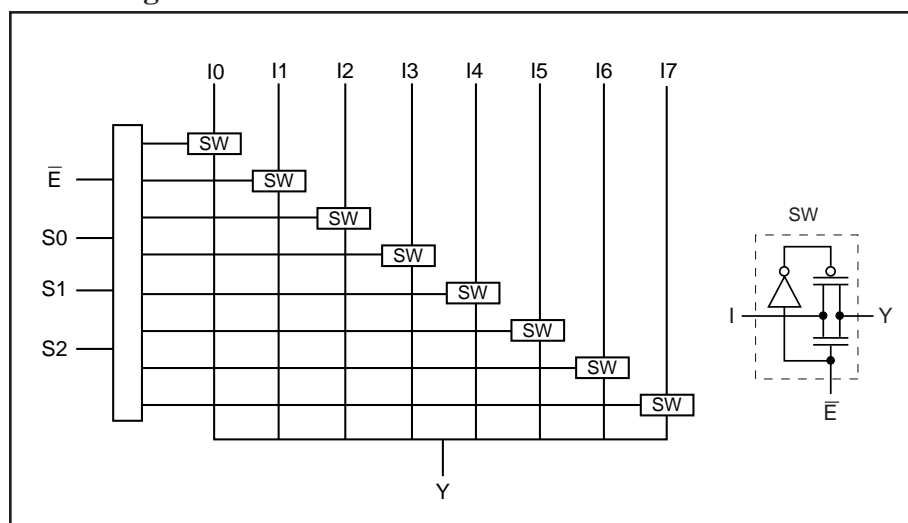
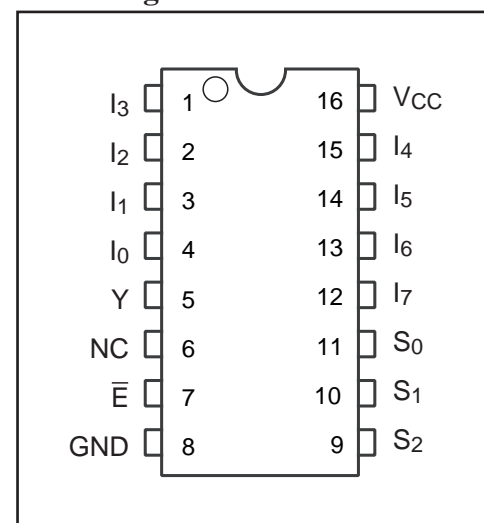

Features

- Near-Zero propagation delay
- 5Ω switches connect inputs to outputs
- Ultra Low Quiescent Power (0.1μA typical)
– Ideally suited for notebook applications
- Pin compatible with 74 series 251 logic devices
- Packaging (Pb-free & Green available):
– 16-pin 150-mil wide plastic QSOP (Q)
– 16-pin 173-mil wide plastic TSSOP (L)

Description

Pericom Semiconductor's PI3B3251 is a 3.3V Dual 8:1 Multiplexer/Demultiplexer with three-state outputs that is pinout compatible with the PI74FCT251T, 74F251, and 74ALS/AS/LS 251. Inputs can be connected to outputs with low On-Resistance (5Ω) with no additional ground bounce noise or propagation delay.

Block Diagram

Pin Configuration

Truth Table⁽¹⁾

\bar{E}	Select			Y	Function
	S2	S1	S0		
H	X	X	X	Hi-Z	Disable
L	L	L	L	I ₀	S2-0 = 0
L	L	L	H	I ₁	S2-0 = 1
L	L	H	L	I ₂	S2-0 = 2
L	L	H	H	I ₃	S2-0 = 3
L	H	L	L	I ₄	S2-0 = 4
L	H	L	H	I ₅	S2-0 = 5
L	H	H	L	I ₆	S2-0 = 6
L	H	H	H	I ₇	S2-0 = 7

Pin Description

Pin Name	Description
I ₀₋₇	Data Inputs
S ₀₋₂	Select Inputs
\bar{E}	Enable
Y	Data Outputs
GND	Ground
V _{CC}	Power
NC	No Connect

Note:

1. H = High Voltage Level, L = Low Voltage Level

Maximum Ratings

(Above which the useful life may be impaired. For user guidelines, not tested.)

Storage Temperature	-65°C to +150°C
Ambient Temperature with Power Applied	-40°C to +85°C
Supply Voltage to Ground Potential	-0.5V to +4.6V
DC Input Voltage	-0.5V to +4.6V
DC Output Current.....	120mA
Power Dissipation	0.5W

Note:

Stresses greater than those listed under MAXIMUM RATINGS may cause permanent damage to the device. This is a stress rating only and functional operation of the device at these or any other conditions above those indicated in the operational sections of this specification is not implied. Exposure to absolute maximum rating conditions for extended periods may affect reliability.

DC Electrical Characteristics (Over the Operating Range, $T_A = -40^\circ\text{C}$ to $+85^\circ\text{C}$, $V_{CC} = 3.3\text{V} \pm 10\%$)

Parameters	Description	Test Conditions ⁽¹⁾	Min.	Typ ⁽²⁾	Max.	Units
V_{IH}	Input HIGH Voltage	Guaranteed Logic HIGH Level	2.0			V
V_{IL}	Input LOW Voltage	Guaranteed Logic LOW Level	-0.5		0.8	
I_{IH}	Input HIGH Current	$V_{CC} = \text{Max.}, V_{IN} = V_{CC}$			± 1	μA
I_{IL}	Input LOW Current	$V_{CC} = \text{Max.}, V_{IN} = \text{GND}$			± 1	
I_{OZH}	High Impedance Output Current	$0 \leq I_N, Y \leq V_{CC}$			± 1	
V_{IK}	Clamp Diode Voltage	$V_{CC} = \text{Min.}, I_{IN} = -18\text{mA}$			-1.2	V
R_{ON}	Switch On-Resistance ⁽³⁾	$V_{CC} = \text{Min.}, V_{IN} = 0.0\text{V}, I_{ON} = 48\text{mA}$ or 64mA		5	8	Ω
		$V_{CC} = \text{Min.}, V_{IN} = 2.4\text{V}, I_{ON} = 15\text{mA}$		10	17	

Notes:

1. For Max. or Min. conditions, use appropriate value specified under Electrical Characteristics for the applicable device type.
2. Typical values are at $V_{CC} = 3.3\text{V}$, $T_A = 25^\circ\text{C}$ ambient and maximum loading.
3. Measured by the voltage drop between I and Y pin at indicated current through the switch. On-Resistance is determined by the lower of the voltages on the two (I,Y) pins.

Capacitance ($T_A = 25^\circ\text{C}$, $f = 1\text{ MHz}$)

Parameters ⁽¹⁾	Description	Test Conditions	Typ.	Units
C_{IN}	Input Capacitance	$V_{IN} = 0\text{V}$	3.0	pF
$C_{I(OFF)}$	$I_0 - I_7$ Capacitance, Switch Off		8.0	
$C_{Y(OFF)}$	Y Capacitance, Switch Off		64.0	
$C_{I(ON)}$	$I_0 - I_7$ Capacitance, Switch On		72.0	

Note:

1. This parameter is determined by device characterization but is not production tested.

Power Supply Characteristics

Parameters	Description	Test Conditions ⁽¹⁾		Min.	Typ. ⁽²⁾	Max.	Units
I _{CC}	Quiescent Power Supply Current	V _{CC} = Max.	V _{IN} = GND or V _{CC}		0.1	3	μA
ΔI _{CC}	Supply Current per Input @ TTL HIGH	V _{CC} = Max.	V _{IN} = 3.0V ⁽³⁾			750	

Notes:

1. For Max. or Min. conditions, use appropriate value specified under Electrical Characteristics for the applicable device.
2. Typical values are at V_{CC} = 3.3V, +25°C ambient.
3. Per TTL driven input (control input only); I and Y pins do not contribute to I_{CC}.

Switching Characteristics over Operating Range

Parameters	Description	Conditions	Com.		Units
			Min.	Max.	
t _{PD}	Propagation Delay ^(1,2) , In to Y	C _L = 50pF R _L = 500Ω		0.25	ns
t _{SY}	Bus Enable Time, S _n to Y		1	4.5	
t _{PZH} t _{PZL}	Bus Enable Time, \bar{E} to Y		1	3.5	
t _{PHZ} t _{PLZ}	Bus Disable Time, \bar{E} to Y		1	5.5	

Notes:

1. This parameter is guaranteed but not tested on Propagation Delays.
2. The bus switch contributes no propagational delay other than the RC delay of the On-Resistance of the switch and the load capacitance. The time constant for the switch alone is of the order of 0.25ns for 50pF load. Since this time constant is much smaller than the rise/fall times of typical driving signals, it adds very little propagational delay to the system. Propagational delay of the bus switch when used in a system is determined by the driving circuit on the driving side of the switch and its interaction with the load on the driven side.

Applications Information

Logic Inputs

The logic control inputs can be driven up to +3.6V regardless of the supply voltage. For example, given a +3.3V supply, IN may be driven low to 0V and high to 3.6V. Driving IN Rail-to-Rail® minimizes power consumption.

Power-Supply Sequencing and Hot-Plug Information

Proper power-supply sequencing is recommended for all CMOS devices. Always apply V_{CC} and GND before applying signals to input/output or control pins.

Rail-to-Rail is a registered trademark of Nippon Motorola, Ltd.

Packaging Mechanical: 16-pin QSOP (Q)

DOCUMENT CONTROL NO.
PD - 1201

REVISION: G
DATE: 11/07/07

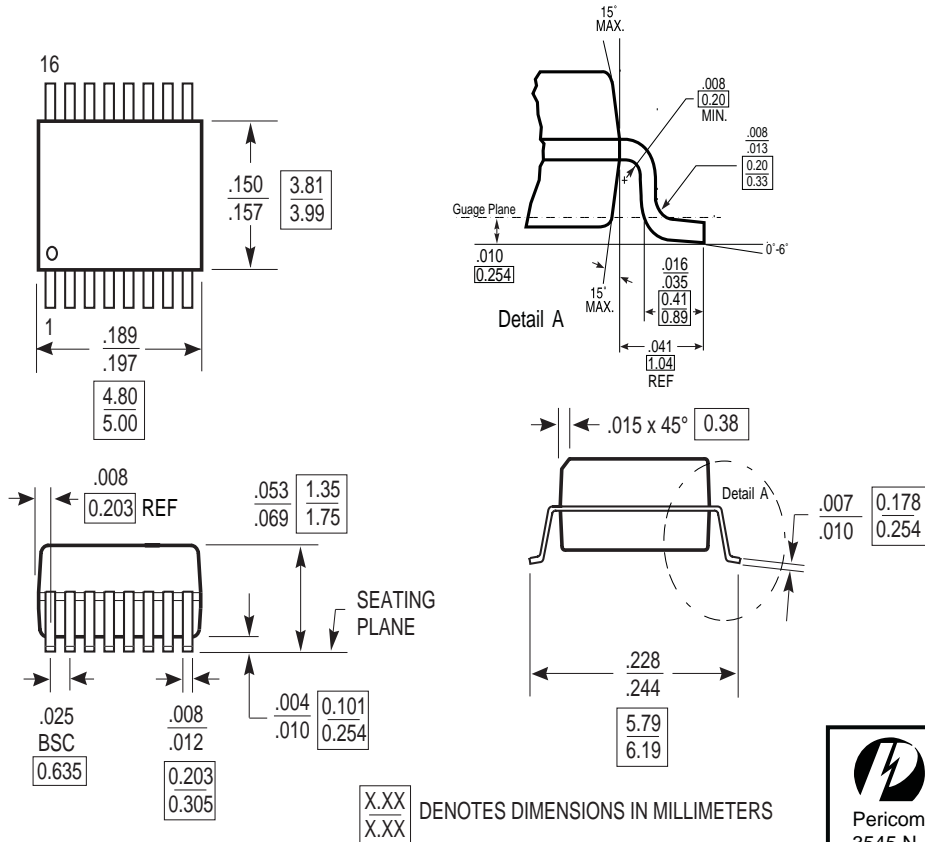

X.XX / X.XX DENOTES DIMENSIONS IN MILLIMETERS

- Note:
- 1) Controlling dimensions in inches.
 - 2) Ref: JEDEC MO-137B/AB.
 - 3) Dimensions do not include mold flash, protrusions or gate burrs



Pericom Semiconductor Corporation
3545 N. 1st Street, San Jose, CA 95134
1-800-435-2335 • www.pericom.com

DESCRIPTION: 16-Pin 150-Mil Wide QSOP

PACKAGE CODE: Q

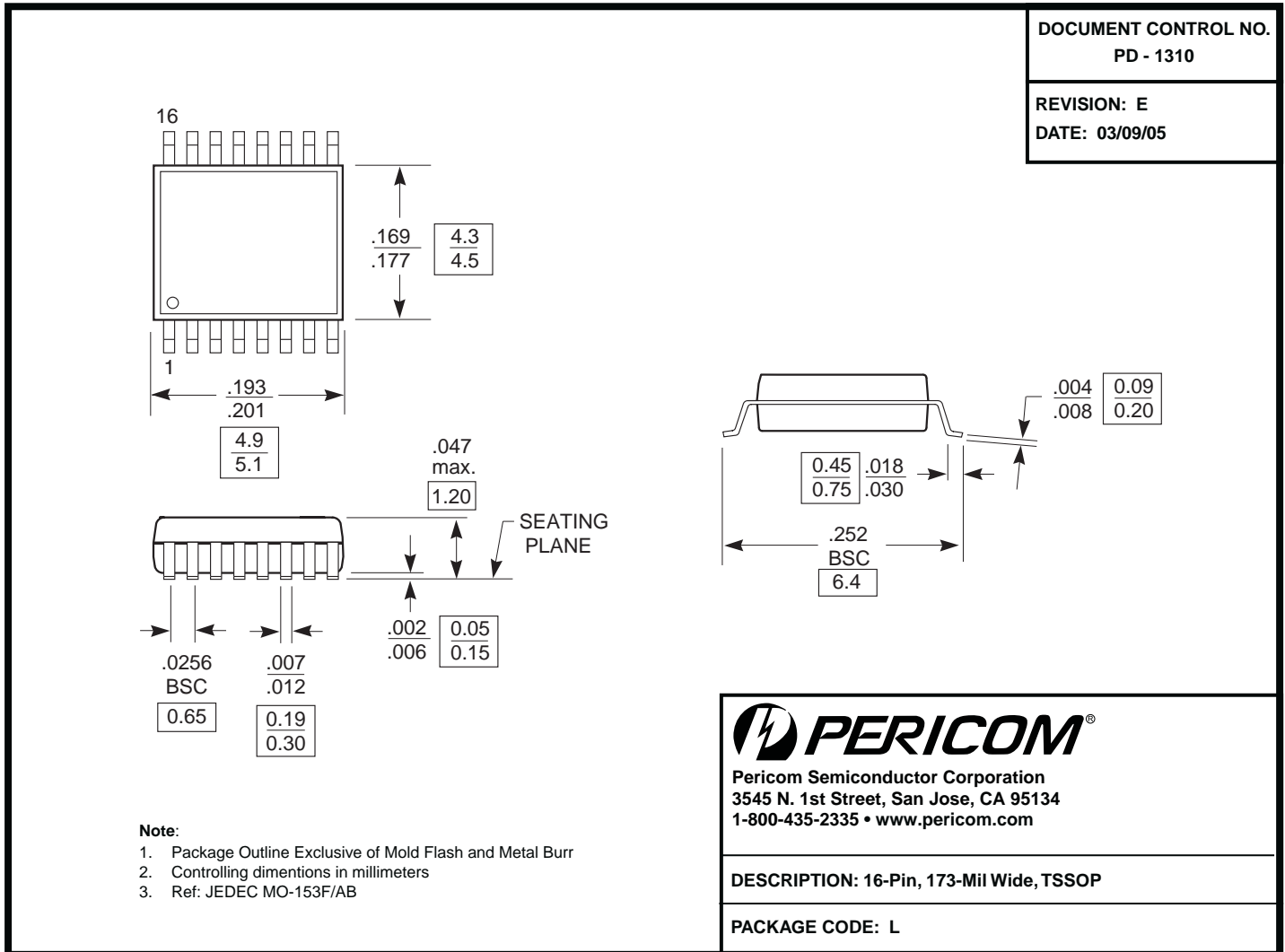
Packaging Mechanical: 16-pin TSSOP (L)

Ordering Information

Ordering Code	Package Code	Package Description
PI3B3251QE	Q	Pb-free & Green, 16-pin QSOP
PI3B3251LE	L	Pb-free & Green, 16-Pin TSSOP

Notes:

- Thermal characteristics can be found on the company web site at www.pericom.com/packaging/
- "E" denotes Pb-free and Green
- Adding an "X" at the end of the ordering code denotes tape and reel packaging

Mouser Electronics

Authorized Distributor

Click to View Pricing, Inventory, Delivery & Lifecycle Information:

[Diodes Incorporated:](#)

[PI3B3251LEX](#) [PI3B3251LE](#) [PI3B3251QE](#)

Компания «Life Electronics» занимается поставками электронных компонентов импортного и отечественного производства от производителей и со складов крупных дистрибьюторов Европы, Америки и Азии.

С конца 2013 года компания активно расширяет линейку поставок компонентов по направлению коаксиальный кабель, кварцевые генераторы и конденсаторы (керамические, пленочные, электролитические), за счёт заключения дистрибьюторских договоров

Мы предлагаем:

- Конкурентоспособные цены и скидки постоянным клиентам.
- Специальные условия для постоянных клиентов.
- Подбор аналогов.
- Поставку компонентов в любых объемах, удовлетворяющих вашим потребностям.
- Приемлемые сроки поставки, возможна ускоренная поставка.
- Доставку товара в любую точку России и стран СНГ.
- Комплексную поставку.
- Работу по проектам и поставку образцов.
- Формирование склада под заказчика.
- Сертификаты соответствия на поставляемую продукцию (по желанию клиента).
- Тестирование поставляемой продукции.
- Поставку компонентов, требующих военную и космическую приемку.
- Входной контроль качества.
- Наличие сертификата ISO.

В составе нашей компании организован Конструкторский отдел, призванный помогать разработчикам, и инженерам.

Конструкторский отдел помогает осуществить:

- Регистрацию проекта у производителя компонентов.
- Техническую поддержку проекта.
- Защиту от снятия компонента с производства.
- Оценку стоимости проекта по компонентам.
- Изготовление тестовой платы монтаж и пусконаладочные работы.



Тел: +7 (812) 336 43 04 (многоканальный)

Email: org@lifeelectronics.ru