



MAX3678 Evaluation Kit

General Description

The MAX3678 evaluation kit (EV kit) is a fully assembled and tested demonstration board that simplifies evaluation of the MAX3678 low-jitter frequency synthesizer with intelligent dynamic switching (IDS). The EV kit includes slide switches to allow easy selection of different modes of operation. Clock I/Os have SMA connectors and are AC-coupled to simplify connection to test equipment. The EV kit is powered by a +3.3V supply and uses LEDs for signal status indicators.

Features

- ◆ Fully Assembled and Tested
- ◆ Slide Switches for Mode Control
- ◆ SMA Connectors and AC-Coupled Clock I/Os
- ◆ Powered by +3.3V Supply
- ◆ LED Signal Status Indicators

Ordering Information

PART	TYPE
MAX3678EVKIT+	EV Kit

+Denotes lead-free/RoHS compliant.

Component List

DESIGNATION	QTY	DESCRIPTION
C1, C6, C7 C11–C13, C16, C18–C22, C24–C27, C29, C30, C32–C39, C41, C42, C46–C50, C62, C63	35	0.1 μ F \pm 10% ceramic capacitors (0402)
C2	1	33 μ F \pm 5% tantalum capacitor (B case)
C3	1	2.2 μ F \pm 10% ceramic capacitor (0805)
C4	1	0.1 μ F \pm 10% ceramic capacitor (0603)
C5	1	0.01 μ F \pm 10% ceramic capacitor (0603)
C28	1	0.22 μ F \pm 10% ceramic capacitor (0402)
D1, D3, D5, D6, D8	5	Green SMD LEDs (1206) Panasonic LNJ311G8PRA
D2, D4, D7	3	Red SMD LEDs (1206) Panasonic LNJ211R8ARA
J1, J2, J5–J12, J14, J15, J19, J20, J22–J29, J44, J45	24	SMA connectors, edge-mount, tab center Johnson 142-0701-851
J4, J13	2	Test points Keystone 5000
L13	1	4.7 μ H \pm 20% inductor Taiyo Yuden CBC3225T4R7M

DESIGNATION	QTY	DESCRIPTION
R1–R5, R15, R16, R17, R37–R46	18	143 Ω \pm 1% resistors (0402)
R6–R11	6	49.9 Ω \pm 1% resistors (0402)
R12, R13, R14, R18–R22	8	332 Ω \pm 1% resistors (0603)
R23, R24, R25	3	10k Ω \pm 1% resistors (0603)
S1	1	Switch, momentary, SPST-NO Panasonic EVQQ2S02W
S2–S5	4	Switches, slide, SPDT Copal Electronics CUS-12TB
S6, S7, S8	3	Switches, slide, SP4T Copal Electronics CUS-14TB
S9, S10	2	Switches, slide, SP3T Copal Electronics CUS-13TB
TP1, TP3, TP20	3	Test points Keystone 5000
U1–U4	4	Dual inverters (6 SC-70) TI SN74LVC2G14DCKR
U7	1	Low-jitter, frequency synthesizer with intelligent dynamic switching (56 TQFN) Microsemi MAX3678UTN+
None	1	PCB: MAX3678 EV Kit+ Circuit Board, Rev A

Evaluates: MAX3678

MAX3678 Evaluation Kit

Quick Start

- 1) Set the slide switches to the following settings:
 PLL_BYPASS = NORMAL
 SEL_CLK = REFCLK0
 IDS_MODE = AUTO
 DM = 133.33M
 DA = 133.33M
 DB = 133.33M
 $\overline{\text{OUTA_EN}}$ = A0, A1
 $\overline{\text{OUTB_EN}}$ = B0
 FB_SEL = INTERNAL
- 2) Connect a +3.3V supply to VCC (J13) and GND (J4). Set the supply current limit to 450mA.
- 3) Using SMA cables, connect a low-jitter 133.33MHz differential clock source to the REFCLK0 input. Verify that the green LEDs switch on for CLK_SELECTED (REFCLK0), $\overline{\text{IN0FAIL}}$, and $\overline{\text{LOCK}}$.
- 4) Using SMA cables, connect the OUTA0 output to test equipment. Terminate all unused enabled outputs (OUTB0 and OUTA1).

Detailed Description

The MAX3678 EV kit simplifies evaluation by providing the hardware needed to evaluate all the MAX3678 functions. Table 1 contains functional descriptions for the switches and indicators.

Clock Inputs

The clock inputs (REFCLK0, REFCLK1, FB_IN) are AC-coupled at the SMA connectors and have on-board 100 Ω differential terminations. For optimal jitter performance it is critical to use a low-jitter, differential, square-wave clock source. If such a source is not available, the clock inputs can be driven with a single-ended sinusoidal or square-wave clock source for functional testing.

Clock Outputs

The clock outputs (OUTA[3:0], OUTB[4:0]) have on-board DC-biasing and are AC-coupled at the SMA connectors to allow direct connection to 50 Ω -terminated test equipment. Unused outputs should be disabled (using switches S9 and S10) or have 50 Ω terminations placed on the SMA connectors.

Table 1. Switch and Indicator Descriptions

COMPONENT	NAME	FUNCTION
S1	MASTER RESET	Momentary switch to reset internal dividers. Not required at power-up. If the output divider settings (DA, DB) are changed on the fly, a reset is required to phase align the outputs.
S2	PLL_BYPASS	Selects normal PLL operation or PLL bypass.
S3	SEL_CLK	Selects the reference clock input (see IDS_MODE).
S4	IDS_MODE	Selects IDS mode of operation. Auto mode allows IDS to automatically select the reference clock input. Manual mode forces IDS to select the reference clock input selected by SEL_CLK.
S5	FB_SEL	Selects internal or external feedback for the PLL. If external is selected, connect any of the A-group or B-group outputs to the FB_IN input. If DA \neq DB, a B-group output must be used.
S6	DM	Selects the frequency of the reference clock inputs.
S7	DA	Selects the frequency of the A-group clock outputs.
S8	DB	Selects the frequency of the B-group clock outputs.
S9	$\overline{\text{OUTA_EN}}$	Selects which A-group outputs are enabled (see note).
S10	$\overline{\text{OUTB_EN}}$	Selects which B-group outputs are enabled (see note).
D1, D2	$\overline{\text{IN0FAIL}}$	REFCLK0 failure indicator (green = pass, red = fail).
D3, D4	$\overline{\text{IN1FAIL}}$	REFCLK1 failure indicator (green = pass, red = fail).
D5, D6	CLK_SELECTED	Indicates which reference clock input is being used by the PLL.
D7, D8	$\overline{\text{LOCK}}$	PLL lock indicator (green = PLL locked, red = PLL not locked).
TP1	$\overline{\text{BUSY}}$	Test point for $\overline{\text{BUSY}}$ indicator. Low indicates IDS is busy switching reference clocks.

Note: Setting $\overline{\text{OUTA_EN}}$ = “—” and $\overline{\text{OUTB_EN}}$ = “B0” at the same time enables a factory test mode and is not a valid mode of operation.

MAX3678 Evaluation Kit

Evaluates: MAX3678

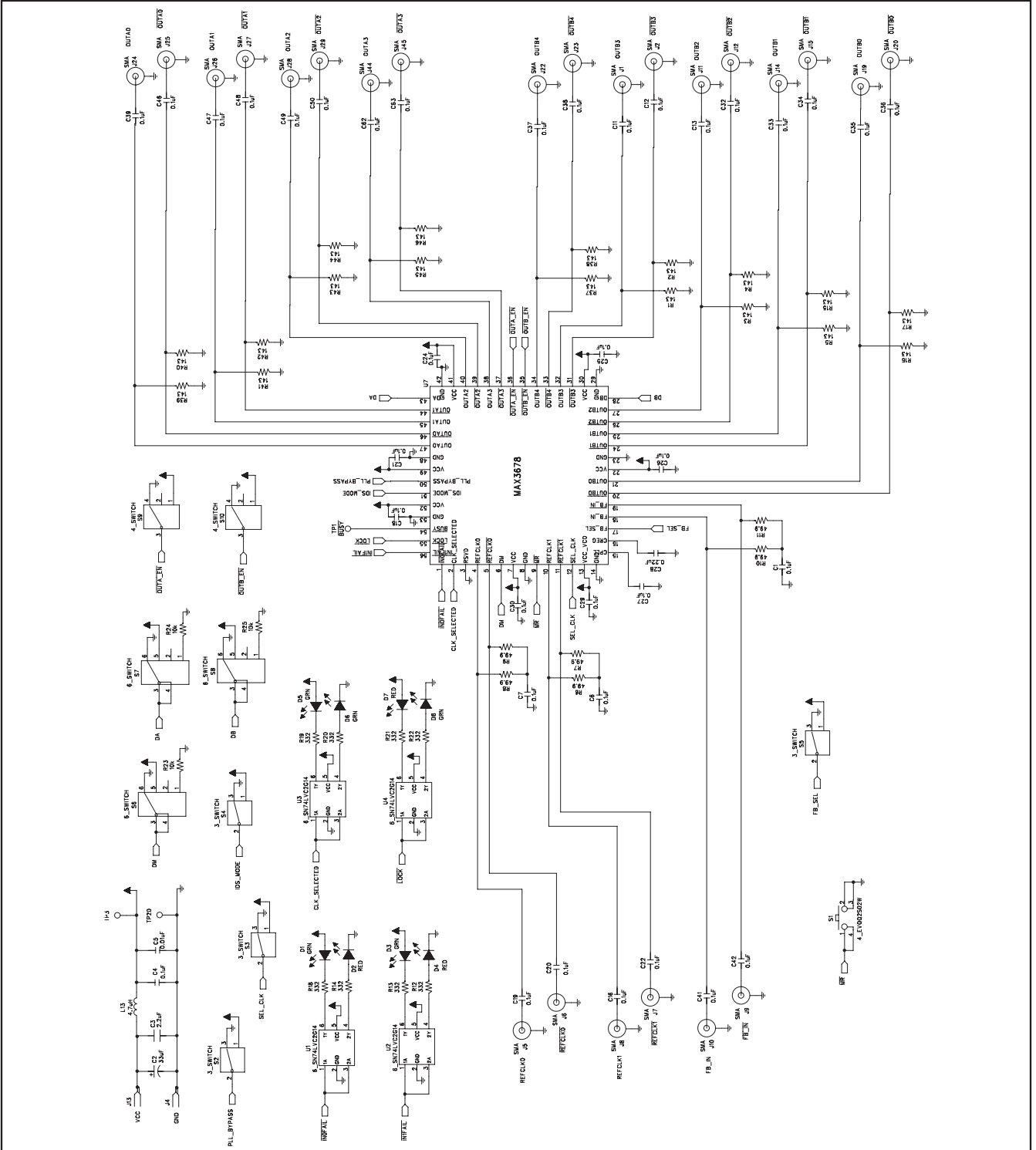

Figure 1. MAX3678 EV Kit Schematic

MAX3678 Evaluation Kit

Evaluates: MAX3678

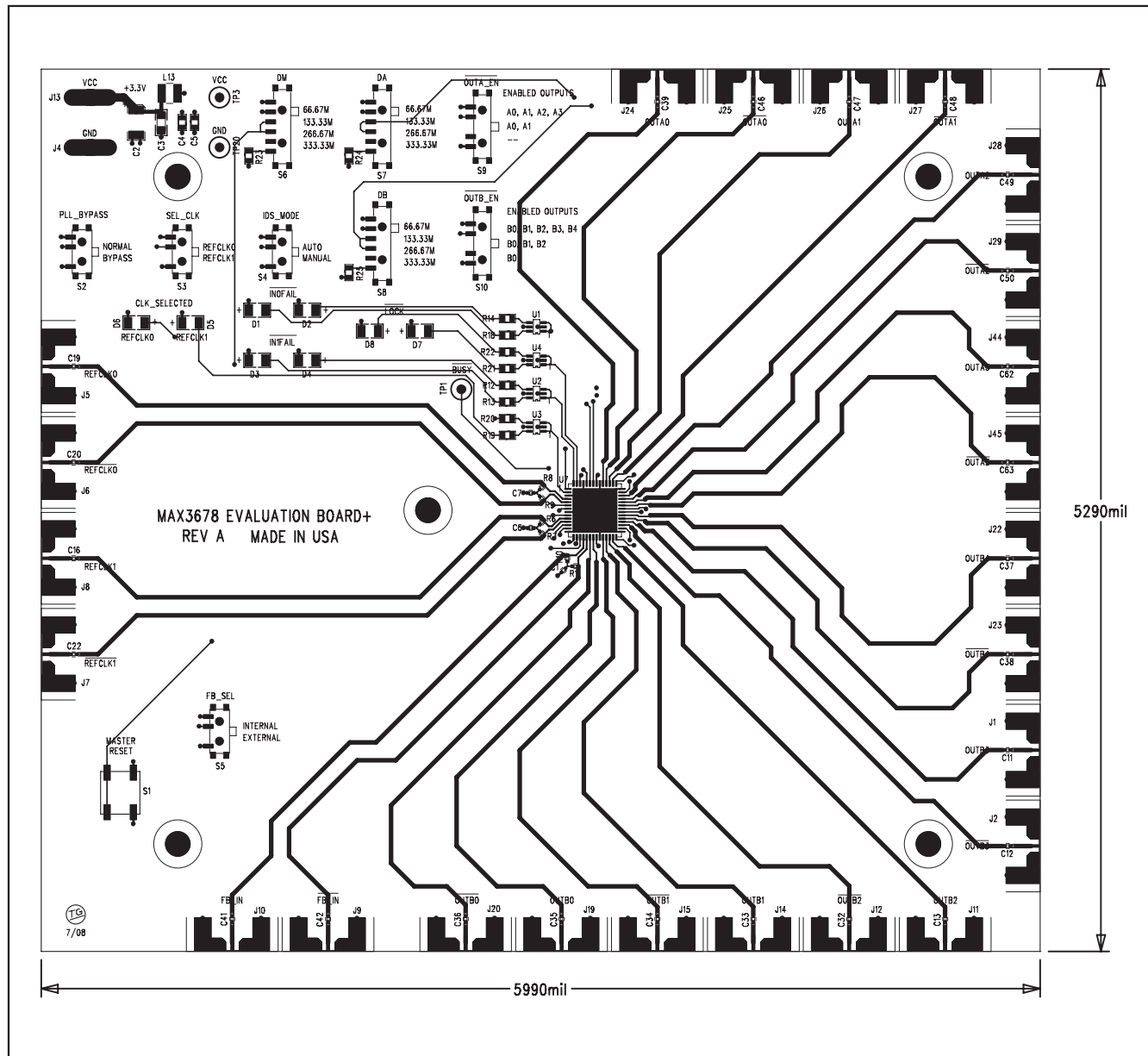

Figure 2. MAX3678 EV Kit Component Placement Guide—Component Side

MAX3678 Evaluation Kit

Evaluates: MAX3678

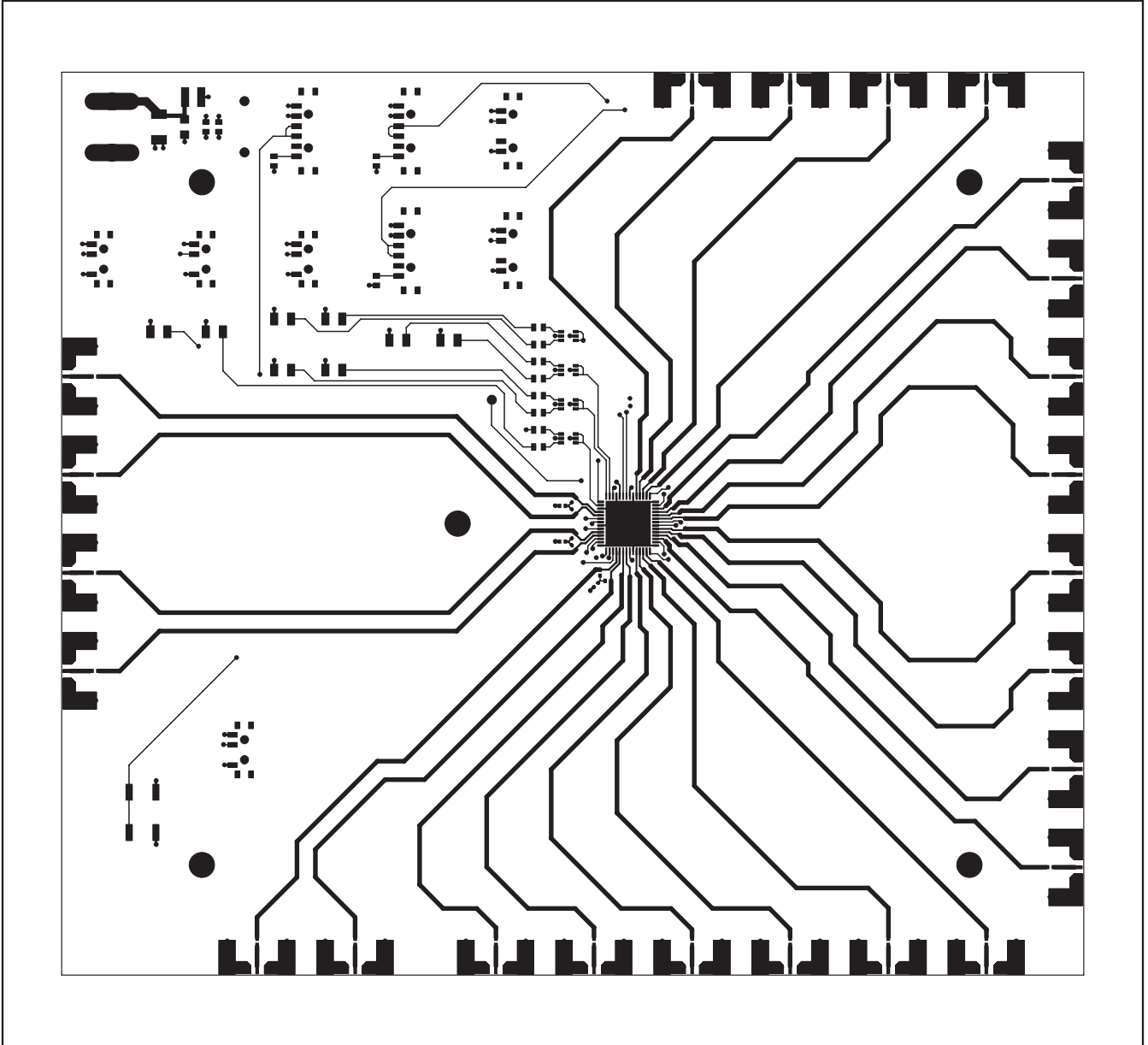

Figure 3. MAX3678 EV Kit PCB Layout—Component Side

MAX3678 Evaluation Kit

Evaluates: MAX3678

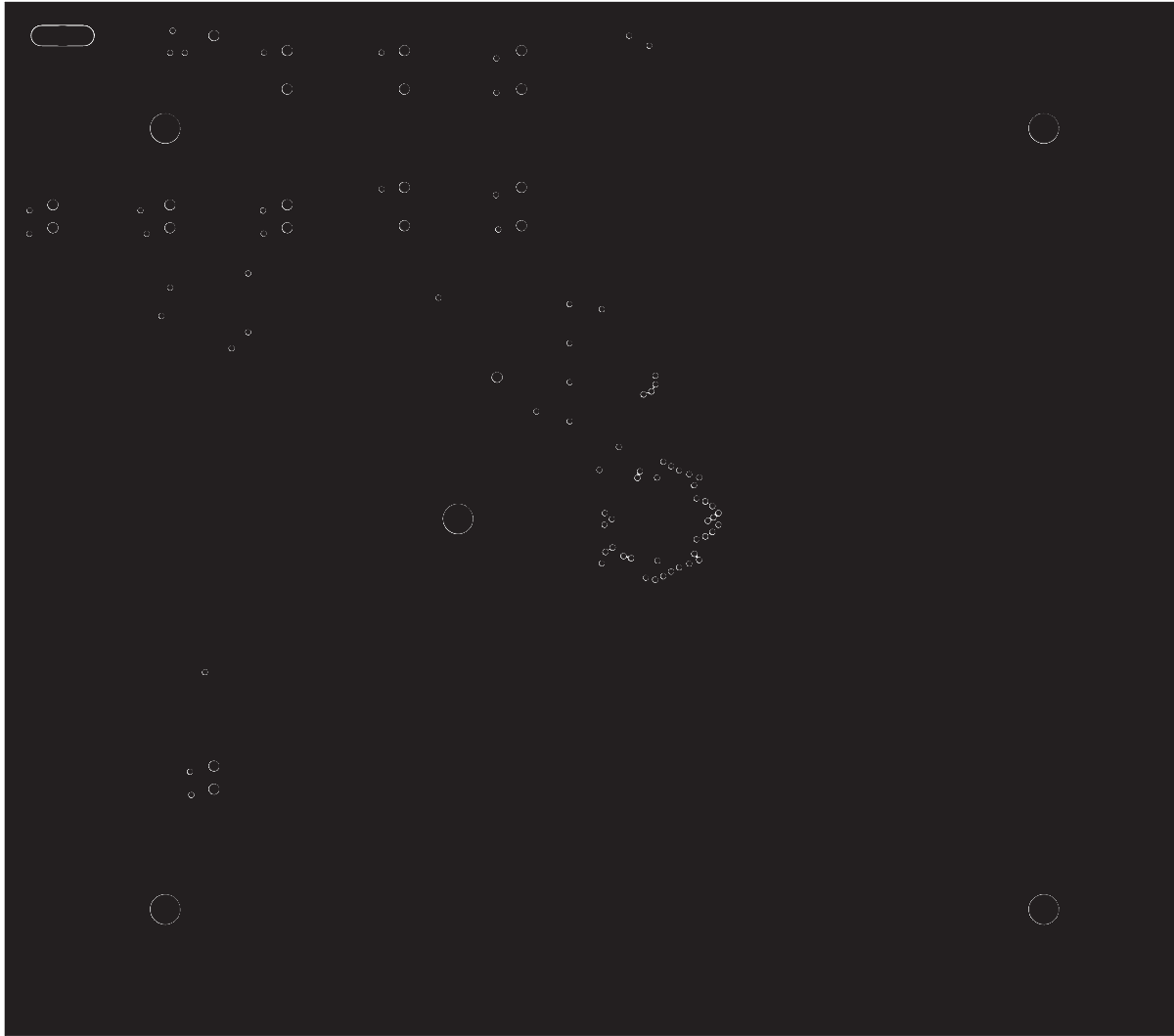

Figure 4. MAX3678 EV Kit PCB Layout—Ground Plane

MAX3678 Evaluation Kit

Evaluates: **MAX3678**

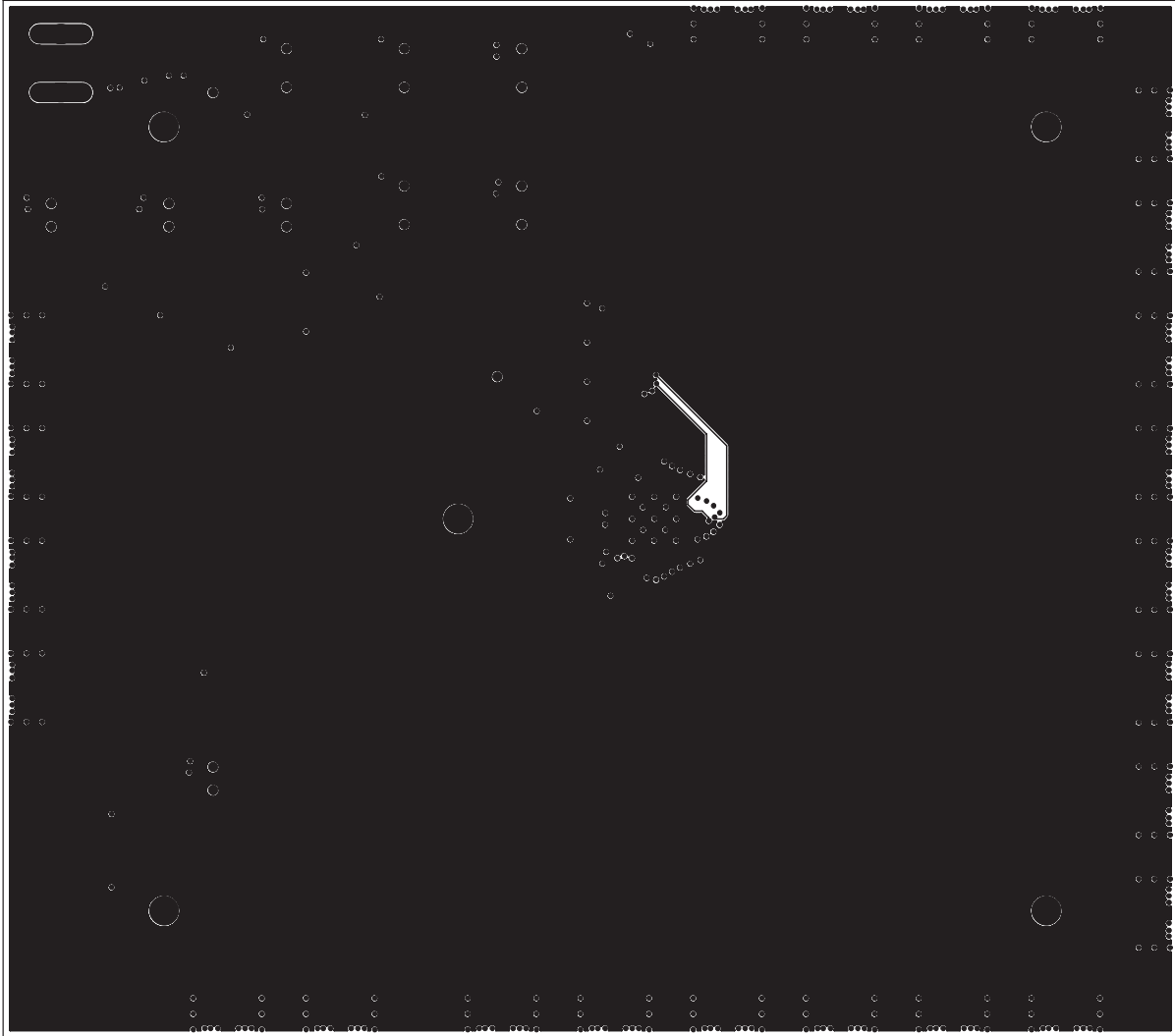

Figure 5. MAX3678 EV Kit PCB Layout—Power Plane

MAX3678 Evaluation Kit

Evaluates: MAX3678

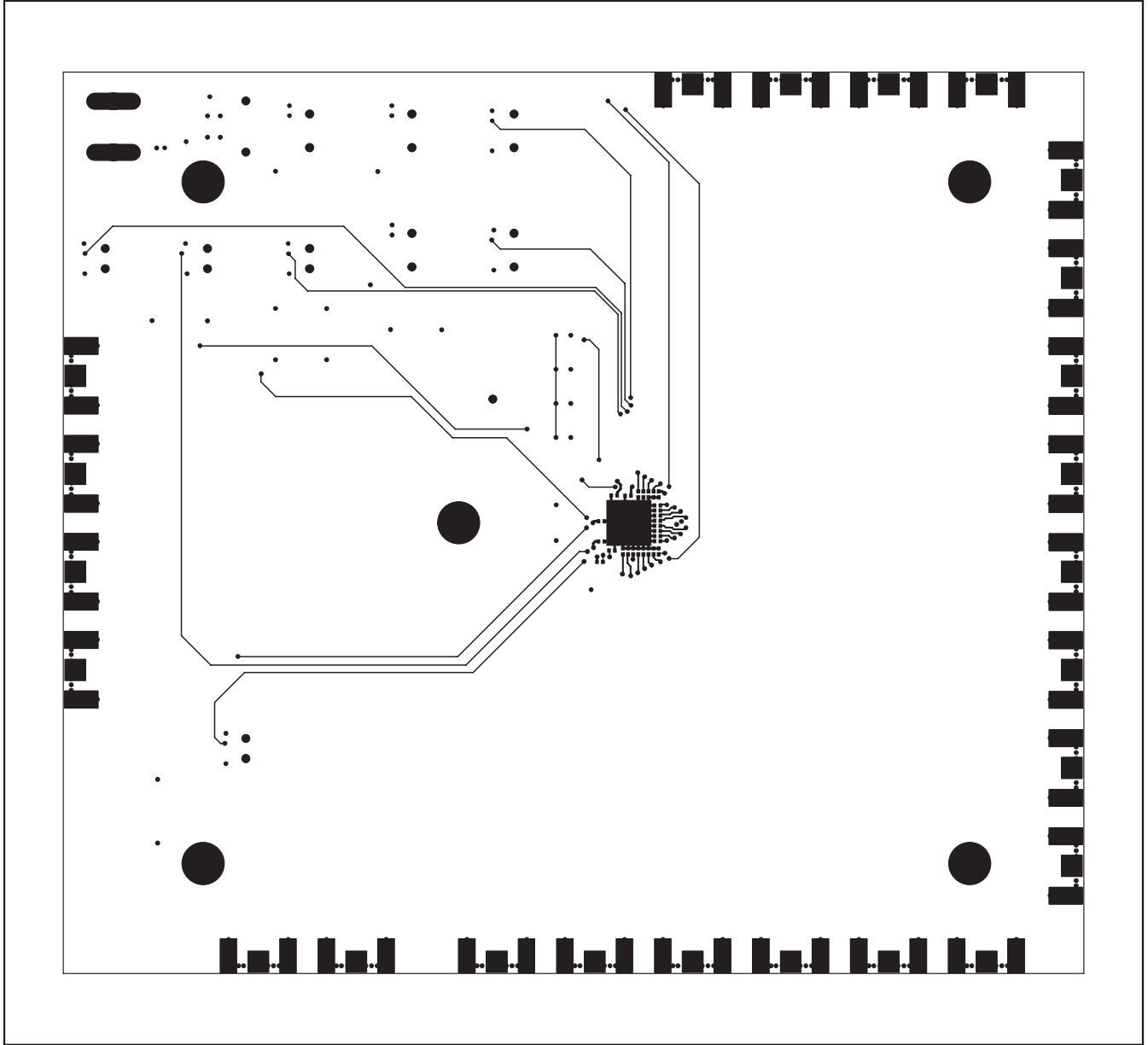

Figure 6. MAX3678 EV Kit PCB Layout—Solder Side

MAX3678 Evaluation Kit

Evaluates: MAX3678

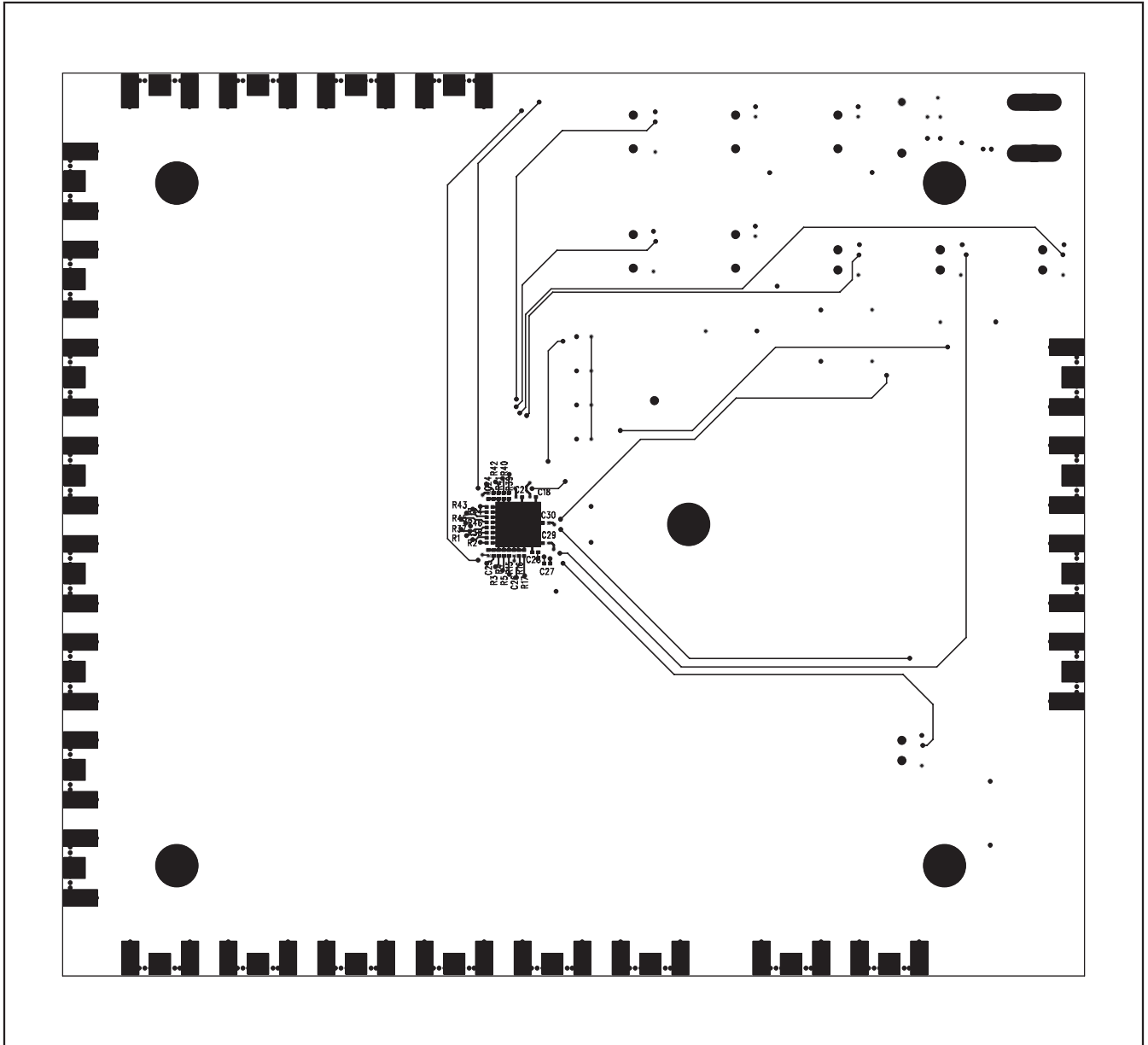

Figure 7. MAX3678 EV Kit Component Placement Guide—Solder Side



Microsemi Corporate Headquarters
One Enterprise, Aliso Viejo CA 92656 USA
Within the USA: +1 (949) 380-6100
Sales: +1 (949) 380-6136
Fax: +1 (949) 215-4996

Microsemi Corporation (NASDAQ: MSCC) offers a comprehensive portfolio of semiconductor solutions for: aerospace, defense and security; enterprise and communications; and industrial and alternative energy markets. Products include high-performance, high-reliability analog and RF devices, mixed signal and RF integrated circuits, customizable SoCs, FPGAs, and complete subsystems. Microsemi is headquartered in Aliso Viejo, Calif. Learn more at www.microsemi.com.

© 2012 Microsemi Corporation. All rights reserved. Microsemi and the Microsemi logo are trademarks of Microsemi Corporation. All other trademarks and service marks are the property of their respective owners.

Компания «Life Electronics» занимается поставками электронных компонентов импортного и отечественного производства от производителей и со складов крупных дистрибьюторов Европы, Америки и Азии.

С конца 2013 года компания активно расширяет линейку поставок компонентов по направлению коаксиальный кабель, кварцевые генераторы и конденсаторы (керамические, пленочные, электролитические), за счёт заключения дистрибьюторских договоров

Мы предлагаем:

- Конкуренспособные цены и скидки постоянным клиентам.
- Специальные условия для постоянных клиентов.
- Подбор аналогов.
- Поставку компонентов в любых объемах, удовлетворяющих вашим потребностям.
- Приемлемые сроки поставки, возможна ускоренная поставка.
- Доставку товара в любую точку России и стран СНГ.
- Комплексную поставку.
- Работу по проектам и поставку образцов.
- Формирование склада под заказчика.
- Сертификаты соответствия на поставляемую продукцию (по желанию клиента).
- Тестирование поставляемой продукции.
- Поставку компонентов, требующих военную и космическую приемку.
- Входной контроль качества.
- Наличие сертификата ISO.

В составе нашей компании организован Конструкторский отдел, призванный помогать разработчикам, и инженерам.

Конструкторский отдел помогает осуществить:

- Регистрацию проекта у производителя компонентов.
- Техническую поддержку проекта.
- Защиту от снятия компонента с производства.
- Оценку стоимости проекта по компонентам.
- Изготовление тестовой платы монтаж и пусконаладочные работы.



Тел: +7 (812) 336 43 04 (многоканальный)
Email: org@lifeelectronics.ru