

Photologic® Dual Channel Encoder



OPB950Z, OPB951

Features:

- Dual channel outputs for Quadrature Output
- Open collector inverter outputs
- 0.010" (0.254 mm) sensor apertures for high resolution
- Snap mount
- OPB950 5±0.5 Volt Vcc, OPB951 4.75 to 16 Volt Vcc



Package 1



Package 2



RoHS

Description:

Each OPB950, series devices consists of an infrared Light Emitting Diode (LED) and a monolithic integrated circuit which incorporates two independent photodiodes, linear amplifiers, Schmitt trigger circuits and output transistors. The device is offered in two versions (see page 2 for package drawings). The OPB950 features a dual open-collector output that is compatible with TTL/LSTTL and can drive up to 8 TTL loads. The OPB951 brings out the anode of the LED for custom power applications.

Applications include linear and rotary encoders with high resolution provided by internal 0.010" (0.254 mm) apertures located in front of each Photologic® sensor on 0.040" (1.02 mm) center line spacing.

Custom electrical, wire, cabling and connectors are available. Contact your local representative or OPTEK for more information.

Applications:

- Mechanical switch replacement
- Speed and direction indication
- Mechanical limit indication
- Rotary encoders
- Edge sensing
- Sliding Door Automotive and Liftgate applications

Ordering Information						
Part Number	Package	LED Peak Wavelength	Sensor	Slot Width / Depth	Aperture Emitter/ Sensor	Lead Length/ Connector
OPB950Z	1	890 nm	Dual TTL	0.200" / 0.350"	0.05" / 0.01"	Molex 5102
OPB951	2		Dual TTL			

OPB950Z

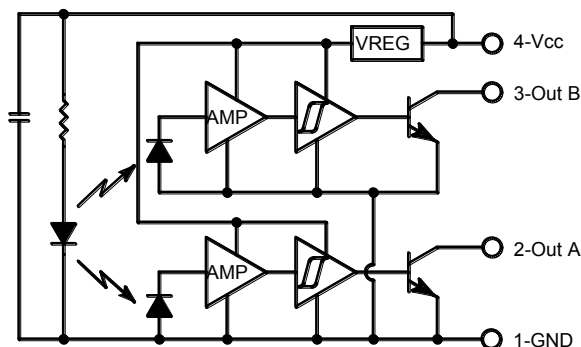

OPB951

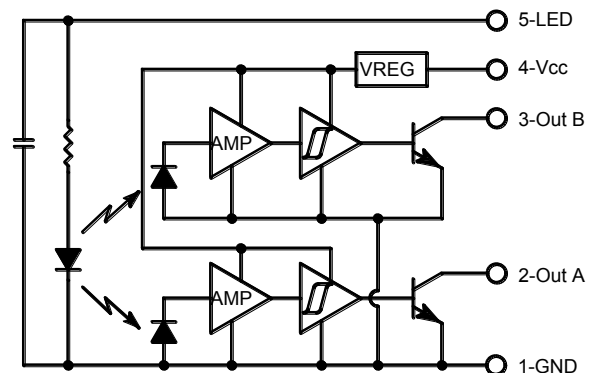

General Note

TT Electronics reserves the right to make changes in product specification without notice or liability. All information is subject to TT Electronics' own data and is considered accurate at time of going to print.

TT Electronics | Optek Technology, Inc.
1645 Wallace Drive, Ste. 130, Carrollton, TX USA 75006 | Ph: +1 972 323 2200
www.ttelectronics.com | sensors@ttelectronics.com

Photologic® Dual Channel Encoder



OPB950Z, OPB951

Electrical Specifications

Absolute Maximum Ratings ($T_A=25^\circ\text{C}$ unless otherwise noted)

Storage & Operating Temperature Range	-40°C to +85°C
---------------------------------------	----------------

Input Diode

Forward DC Current	50 mA
Reverse DC Voltage	2.0 V
Power Dissipation ⁽¹⁾	100 mW

Output Photologic®

Supply Voltage, V_{CC}	OPB950Z / OPB951	5.5 V / 16 V
Voltage at Output		16 V
Power Dissipation ⁽²⁾		200 mW
Sinking Output Current		40 mA

Electrical Characteristics ($T_A = 25^\circ\text{C}$ and $V_{CC} = +5$ Volts unless otherwise noted)

SYMBOL	PARAMETER	MIN	TYP	MAX	UNITS	TEST CONDITIONS
--------	-----------	-----	-----	-----	-------	-----------------

Input LED OPB951 (see op240 for additional information)

V_F	Forward Voltage	-	-	1.80	V	$I_F = 20$ mA
I_R	Reverse Current	-	-	100	μA	$V_R = 2.0$ V
λ_P	Wavelength at Peak Emission	-	890	-	nm	$I_F = 10$ mA

Output Photologic® Sensor (see OPL583 for additional information)

SYMBOL	PARAMETER	MIN	TYP	MAX	UNITS	TEST CONDITIONS
V_{CC}	Operating Supply Voltage ⁽⁴⁾	4.5	-	16	V	-
$E_{ET}^{(+)} / E_{ET}^{(-)}$	Hysteresis Ratio	1.1	1.5	2	-	-
MATCH	Channel Match $E_{ET}^{(+A)} / E_{ET}^{(+B)}$	0.67	1	1.5	-	-
I_{CCL}	Supply Current, Both Outputs Low (LED On, No Target)	-	8.5	12	mA	$E_E = 0.5$ mW/cm ² (no load on output)
I_{CCH}	Supply Current, Both Outputs High (LED Off)	-	3.5	6	mA	$E_E = 0$ mW/cm ² (no load on output)
I_{CCM}	Supply Current, Mixed Output States (one high, one low)	-	6	-	mA	$E_E = 0$ mW/cm ² and 0.5 mW/cm ²
I_{OH}	High Level Output Current	-	1	30	μA	$E_E = 0$ mW/cm ² , $V_{OH} = 16$ V
V_{OL}	Low Level Output Voltage	-	0.21	0.4	V	$E_E = 0$ mW/cm ² , $I_{OL} = 12.8$ mA
T_{PHL} T_{PLH}	Propagation Delay Output High to Low Output Low to High	-	2 10	-	μs μs	$V_{CC} = 5$ V, $R_L = 360$ Ω $E_E = 0$ or 0.5 mW/cm ² , $f = 10$ kHz, D.C. = 50%
t_r t_f	Output Rise Time Output Fall Time	-	20 15	-	ns ns	-

TT Electronics reserves the right to make changes in product specification without notice or liability. All information is subject to TT Electronics' own data and is considered accurate at time of going to print.

Photologic® Dual Channel Encoder

OPB950Z, OPB951



Performance

High Level Output vs Ambient Temperature

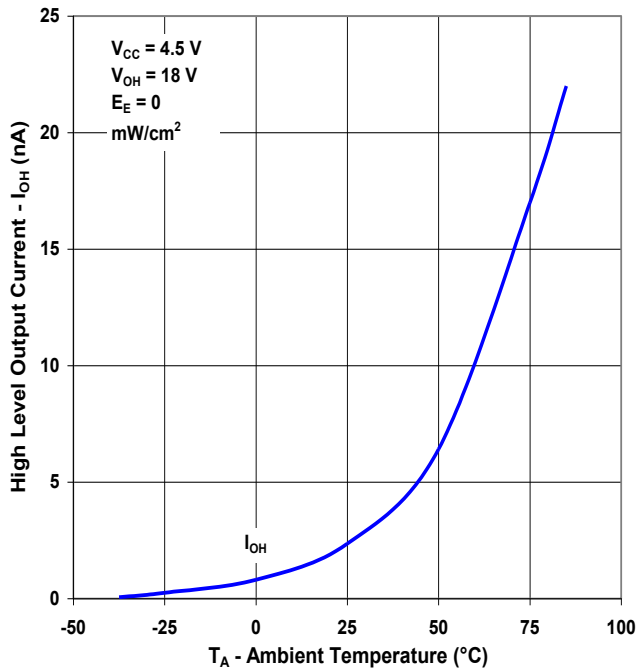

Low Level Output vs Ambient Temperature

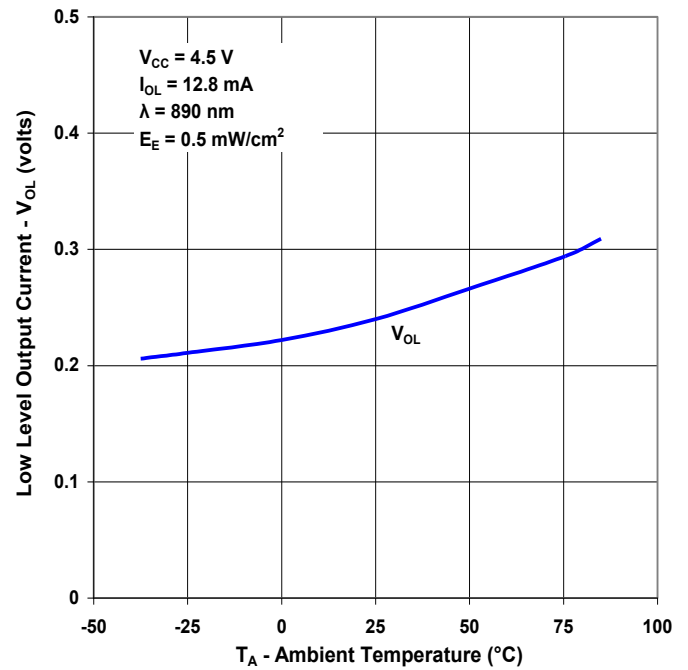

Supply Current vs Ambient Temperature

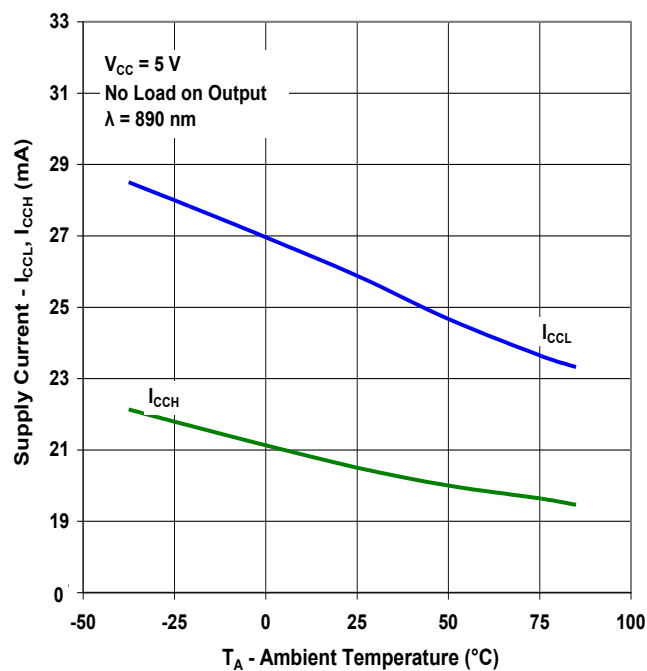

General Note

TT Electronics reserves the right to make changes in product specification without notice or liability. All information is subject to TT Electronics' own data and is considered accurate at time of going to print.

TT Electronics | Optek Technology, Inc.
 1645 Wallace Drive, Ste. 130, Carrollton, TX USA 75006 | Ph: +1 972 323 2200
www.ttelectronics.com | sensors@ttelectronics.com

Photologic® Dual Channel Encoder

OPB950Z, OPB951



Performance

Rise and Fall Time vs Ambient Temperature vs Output Load

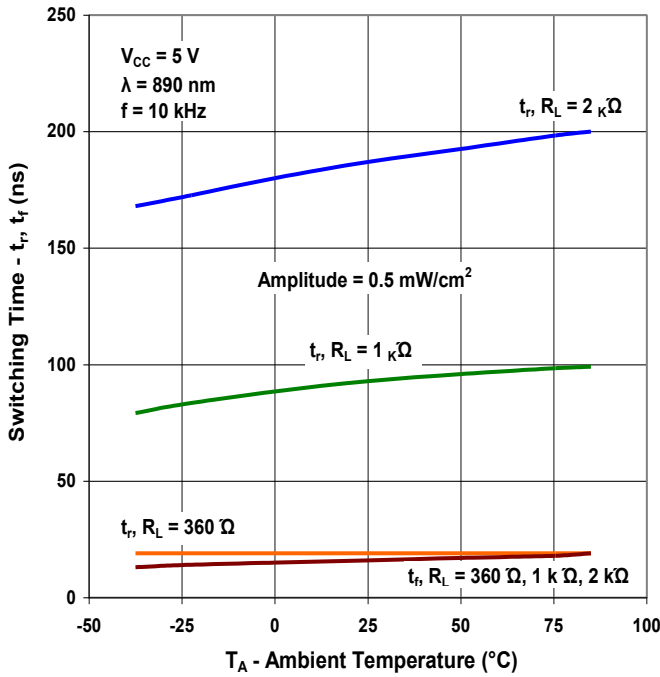

Propagation Delay vs Ambient Temperature

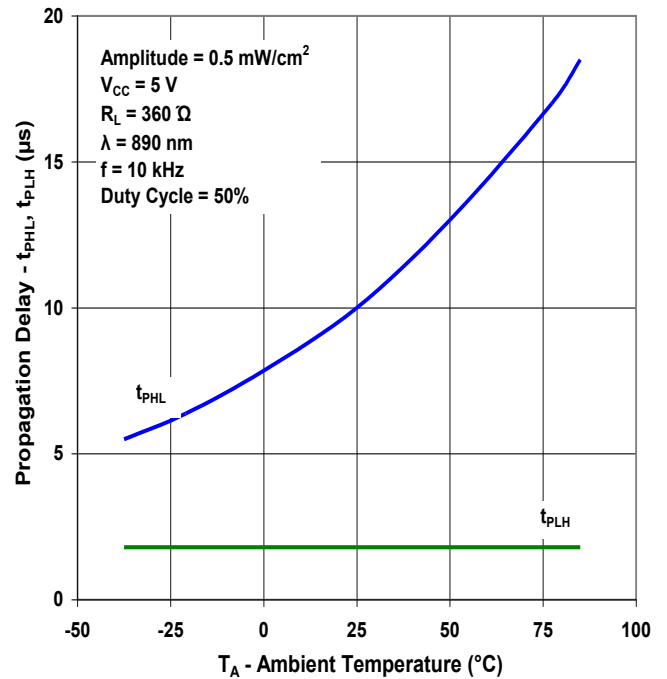

Sensor Output(s)

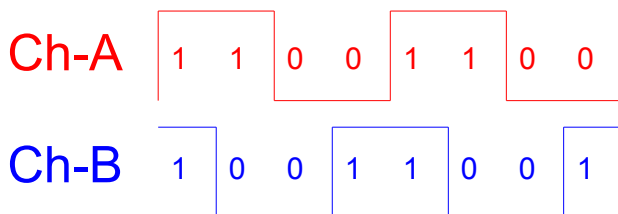

Ideal Target Size & Spacing For Linear or Circular Targets

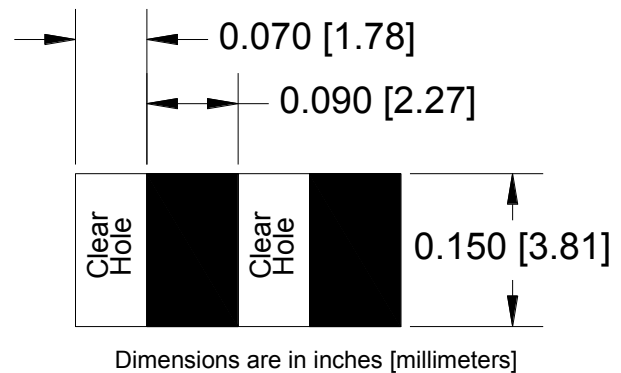

Please consult OPTEK for target design and sensor location relative to the target.

General Note

TT Electronics reserves the right to make changes in product specification without notice or liability. All information is subject to TT Electronics' own data and is considered accurate at time of going to print.

TT Electronics | Optek Technology, Inc.
 1645 Wallace Drive, Ste. 130, Carrollton, TX USA 75006 | Ph: +1 972 323 2200
 www.ttelectronics.com | sensors@ttelectronics.com

Photologic® Dual Channel Encoder



OPB950Z, OPB951

Packaging

Package 1 - OPB950Z

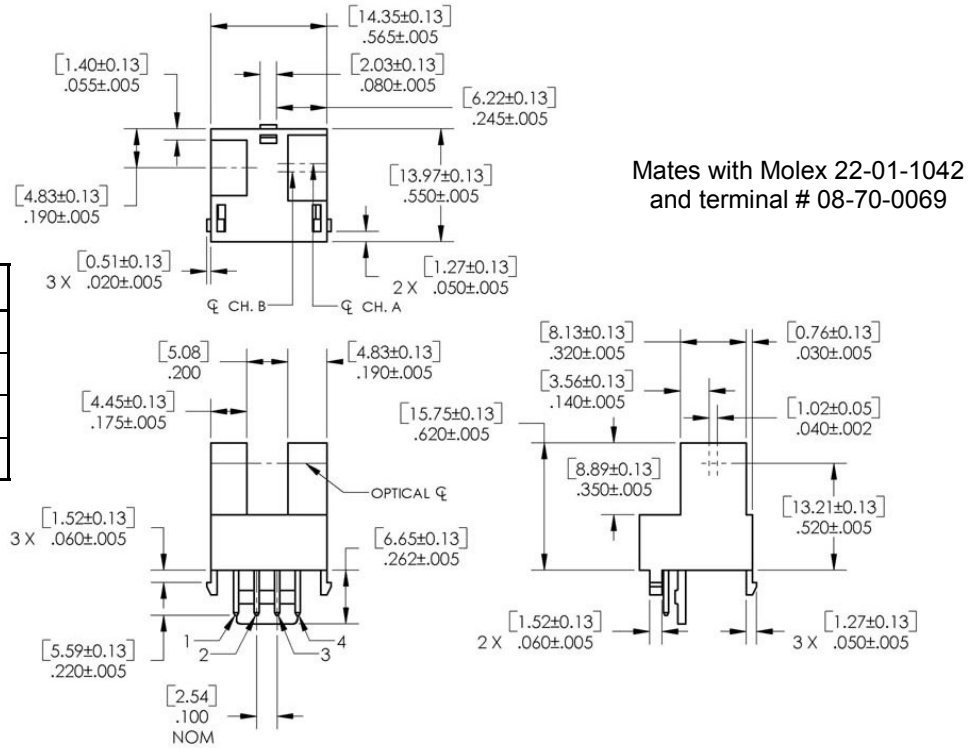

Pin #	Description
1	Ground
2	Output-A
3	Output-B
4	V _{CC}

Package 2 - OPB951

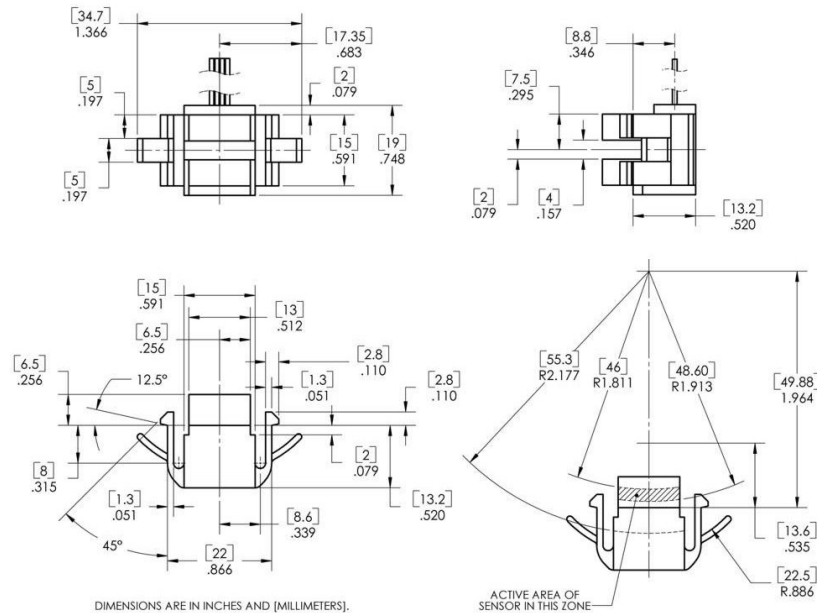

Pin #	Description
1	Output-A
2	Output-B
3	V _{CC}
4	Ground

General Note

TT Electronics reserves the right to make changes in product specification without notice or liability. All information is subject to TT Electronics' own data and is considered accurate at time of going to print.

TT Electronics | Optek Technology, Inc.
1645 Wallace Drive, Ste. 130, Carrollton, TX USA 75006 | Ph: +1 972 323 2200
www.ttelectronics.com | sensors@ttelectronics.com

Компания «Life Electronics» занимается поставками электронных компонентов импортного и отечественного производства от производителей и со складов крупных дистрибьюторов Европы, Америки и Азии.

С конца 2013 года компания активно расширяет линейку поставок компонентов по направлению коаксиальный кабель, кварцевые генераторы и конденсаторы (керамические, пленочные, электролитические), за счёт заключения дистрибьюторских договоров

Мы предлагаем:

- Конкурентоспособные цены и скидки постоянным клиентам.
- Специальные условия для постоянных клиентов.
- Подбор аналогов.
- Поставку компонентов в любых объемах, удовлетворяющих вашим потребностям.
- Приемлемые сроки поставки, возможна ускоренная поставка.
- Доставку товара в любую точку России и стран СНГ.
- Комплексную поставку.
- Работу по проектам и поставку образцов.
- Формирование склада под заказчика.
- Сертификаты соответствия на поставляемую продукцию (по желанию клиента).
- Тестирование поставляемой продукции.
- Поставку компонентов, требующих военную и космическую приемку.
- Входной контроль качества.
- Наличие сертификата ISO.

В составе нашей компании организован Конструкторский отдел, призванный помогать разработчикам, и инженерам.

Конструкторский отдел помогает осуществить:

- Регистрацию проекта у производителя компонентов.
- Техническую поддержку проекта.
- Защиту от снятия компонента с производства.
- Оценку стоимости проекта по компонентам.
- Изготовление тестовой платы монтаж и пусконаладочные работы.



Тел: +7 (812) 336 43 04 (многоканальный)

Email: org@lifeelectronics.ru