

REVISIONS			
LTR	DESCRIPTION	DATE	APPROVED
H1	REVISED PER ECO-11-005139	29MAR11	HMR
J	REVISED PER ECO-12-021161	04DEC12	G.WELLS



CODE 54
STRAIGHT ADAPTER

NOTES:

1. THIS PRODUCT IS DESIGNED TO TERMINATE A BRAIDED CABLE SHIELD AND A HEAT SHRINKABLE LIPPED BOOT TO A CONNECTOR.
2. SEE CH00-0250-008 FOR ORDERING INFORMATION, MODIFICATIONS AND ADDITIONAL DIMENSIONS.
3. SEE DRAWING "TR" FOR DETAIL ON TINEL-LOCK RING. RINGS ARE DESIGNED TO BE HEATED ELECTRICALLY. ALL RINGS ARE MARKED WITH THERMOCHROMIC PAINT WHICH CHANGES COLOR WHEN INSTALLATION TEMPERATURE IS REACHED.
4. ADAPTER TO BE PERMANENTLY MARKED WITH CODE IDENT. NO. AND PART NO. LESS RING DESIGNATOR (E.G.: 06090-TXR54AB00-1206). RINGS SHALL BEAR NO MARKING.
5. FOR LARGER ENTRY SIZES, A 2 PIECE ADAPTER (TYPE II) IS SUPPLIED.
6. ADAPTER MATES TO MIL-C-81703, SERIES III, MS3424, MS3446, MS3464, MS3467, MS3468, CLASS E & L.
7. ADAPTER MATES TO MIL-C-5015G, MS3400 SERIES, CLASS D, E, K, L, U & W: MS3400, MS3401, MS3404, MS3406, MS3450, MS3451, MS3454, MS3456, MS3470, MS3471, MS3472, MS3474, MS3475, MS3476. MIL-C-83723, SERIES II, CLASS A & L. MIL-C-83723, SERIES I & III, CLASS A, G, K, R & S: M83723/1, /2, /3, /4, /5, /6, /7, /8, /13, /14, /36, /37, /38, /39, /40, /41, /42, /43, /48, /49, /65, /66, /67, /68, /69, /70, /71, /72, /73, /74, /75, /76, /77, /78, /82, /83, /84, /85, /86, /87, /91, /92, /95, /97, /98, (MS3155 CONTROLLED INTERFACE).
8. THESE DIMENSIONS APPLY IF A SELF-LOCKING COUPLING NUT IS USED. (MOD. CODE "S")

If this document is printed it becomes uncontrolled. Check for the latest revision

© 2011-2012 TYCO ELECTRONICS. ALL RIGHTS RESERVED

Raychem Adapters
CUSTOMER DRAWING

UNLESS OTHERWISE SPECIFIED
DIMENSIONS ARE IN INCHES.
METRIC DIMENSIONS ARE
IN BRACKETS.

DECIMALS
.XXX ± — [mm]
.XX ± — [mm]
.X ± — [mm]

ANGLES
.X ± —

DRAWN R. RAMIREZ	DATE 03-18-93
CHECKED	DATE
APPROVED	DATE
APPROVED	DATE
CAD NAME txr54_1_j_cd_J	



TE Connectivity

TITLE
TINEL-LOCK™ ADAPTER



SIZE A	CODE IDENT. NO. 06090	DWG. NO. TXR54
DO NOT SCALE THIS DWG		SHEET 1 OF 3



STRAIGHT ADAPTER-TYPE I

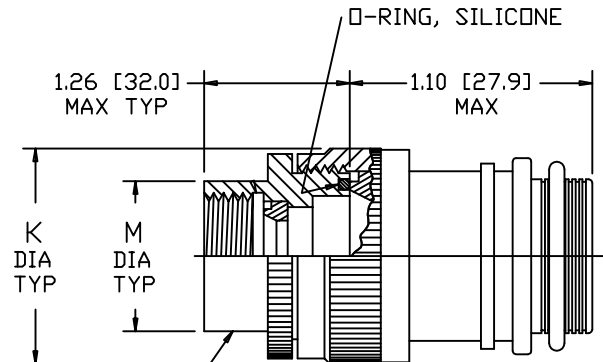

STRAIGHT ADAPTER-TYPE II



45° ADAPTER-TYPE I



45° ADAPTER-TYPE II



90° ADAPTER TYPE I



90° ADAPTER TYPE II

Raychem Adapters
CUSTOMER DRAWING

If this document is printed it becomes uncontrolled. Check for the latest revision

SIZE	CODE IDENT. NO.	DWG. NO.	REV
A	06090	TXR54	J
DO NOT SCALE THIS DWG		CAD NAME txr54_2_j_cd_j	SHEET 2 OF 3

ORDER NO.	SHELL SIZE		MAX ENTRY SIZE TYPE I 	A THREAD CLASS 2B	B DIA MAX	B DIA MAX 	C MAX	D MAX	E MAX	M DIA MAX	W MAX
											
03	3		04	.562-24 UNEF	.669 [16.99]	.940 [23.88]	.75 [19.1]	.91 [23.1]	1.13 [28.7]	.695 [17.65]	.85 [21.6]
08		8 & 8S	04	.500-20 UNF	.617 [15.67]	.890 [22.61]	.75 [19.1]	.91 [23.1]	1.10 [27.9]	.630 [16.00]	.85 [21.6]
10		10, 10S & 10SL	06	.625-24 UNEF	.734 [18.64]	1.010 [25.65]	.77 [19.6]	.93 [23.6]	1.16 [29.5]	.757 [19.23]	.97 [24.6]
12	7	12 & 12S	08	.750-20 UNEF	.858 [21.79]	1.140 [28.96]	.80 [20.3]	.95 [24.1]	1.22 [31.0]	.882 [22.40]	1.10 [27.9]
14	12	14 & 14S	08	.875-20 UNEF	.984 [24.99]	1.260 [32.00]	.82 [20.8]	.97 [24.6]	1.28 [32.5]	1.007 [25.58]	1.16 [29.5]
16	19	16 & 16S	10	1.000-20 UNEF	1.112 [28.24]	1.390 [35.31]	.84 [21.3]	1.00 [25.4]	1.35 [34.3]	1.132 [28.75]	1.28 [32.5]
18	27	18	12	1.062-18 UNEF	1.218 [30.94]	1.510 [38.35]	.86 [21.8]	1.01 [25.7]	1.40 [35.6]	1.218 [30.94]	1.35 [34.3]
20	37	20	14	1.188-18 UNEF	1.345 [34.16]	1.640 [41.66]	.88 [22.4]	1.04 [26.4]	1.46 [37.1]	1.345 [34.16]	1.47 [37.3]
22		22	16	1.312-18 UNEF	1.468 [37.29]	1.760 [44.70]	.91 [23.1]	1.06 [26.9]	1.53 [38.9]	1.468 [37.29]	1.60 [40.6]
24		24	18	1.438-18 UNEF	1.593 [40.46]	1.890 [48.00]	.93 [23.6]	1.09 [27.7]	1.59 [40.4]	1.593 [40.46]	1.72 [43.7]
28		28	22	1.750-18 UNS	1.969 [50.01]	2.140 [54.36]	.98 [24.9]	1.13 [28.7]	1.78 [45.2]	1.969 [50.01]	1.97 [50.0]
32		32	24	2.000-18 UNS	2.219 [56.36]	2.400 [60.96]	1.03 [26.2]	1.19 [30.2]	1.90 [48.3]	2.219 [56.36]	2.22 [56.4]
36		36	24	2.250-16 UN	2.469 [62.71]	2.640 [67.06]	1.08 [27.4]	1.23 [31.2]	2.03 [51.6]	2.469 [62.71]	2.35 [59.7]
40		40	24	2.500-16 UN	2.719 [69.06]	2.890 [73.41]	1.12 [28.4]	1.28 [32.5]	2.15 [54.6]	2.719 [69.06]	2.60 [66.0]
44		44	24	2.750-16 UN	2.969 [75.41]	3.140 [79.76]	1.17 [29.7]	1.33 [33.8]	2.28 [57.9]	2.969 [75.41]	2.85 [72.4]
48		48	24	3.000-16 UN	3.219 [81.76]	3.390 [86.11]	1.22 [31.0]	1.38 [35.1]	2.40 [61.0]	3.219 [81.76]	3.16 [80.3]
61	61		18	1.500-18 UNEF	1.653 [41.99]	1.880 [47.75]	.94 [23.9]	1.09 [27.7]	1.62 [41.1]	1.653 [41.99]	1.78 [45.2]

ENTRY SIZE	Z +.010 -.020	S DIA	Y ±.015 [±0.38]	F MAX	G MAX	H MAX	J MAX	K MAX
04	.250 [6.35]	.376 [9.56] .370 [9.39]	.550 [13.97]	N/A	N/A	N/A	N/A	N/A
05	.312 [7.92]	.438 [11.13] .432 [10.97]	.612 [15.54]	.77 [19.6]	.93 [23.6]	1.19 [30.2]	1.16 [29.5]	.80 [20.3]
06	.375 [9.53]	.501 [12.73] .495 [12.57]	.675 [17.14]	.77 [19.6]	.93 [23.6]	1.19 [30.2]	1.16 [29.5]	.80 [20.3]
07	.437 [11.09]	.563 [14.31] .556 [14.12]	.737 [18.71]	.80 [20.3]	.95 [24.1]	1.38 [35.1]	1.22 [31.0]	.92 [23.4]
08	.500 [12.70]	.626 [15.91] .619 [15.72]	.800 [20.32]	.80 [20.3]	.95 [24.1]	1.38 [35.1]	1.22 [31.0]	.92 [23.4]
10	.625 [15.87]	.752 [19.11] .742 [18.84]	.925 [23.49]	.84 [21.3]	1.00 [25.4]	1.51 [38.4]	1.35 [34.3]	1.18 [30.0]
12	.750 [19.05]	.877 [22.28] .867 [22.02]	1.050 [26.67]	.88 [22.4]	1.01 [25.7]	1.63 [41.4]	1.40 [35.6]	1.35 [34.3]
14	.875 [22.23]	1.002 [25.46] .991 [25.17]	1.175 [29.84]	.88 [22.4]	1.04 [26.4]	1.78 [45.2]	1.46 [37.1]	1.41 [35.8]
16	1.000 [25.40]	1.127 [28.63] 1.116 [28.34]	1.300 [33.02]	.93 [23.6]	1.06 [26.9]	1.88 [47.8]	1.53 [38.9]	1.60 [40.6]
18	1.125 [28.57]	1.252 [31.81] 1.241 [31.52]	1.425 [36.19]	.93 [23.6]	1.09 [27.7]	2.01 [51.1]	1.59 [40.4]	1.66 [42.2]
20	1.250 [31.75]	1.377 [34.98] 1.366 [34.69]	1.550 [39.37]	.98 [24.9]	1.13 [28.7]	2.13 [54.1]	1.78 [45.2]	2.04 [51.8]
22	1.375 [34.93]	1.502 [38.15] 1.488 [37.79]	1.675 [42.55]	1.03 [26.2]	1.38 [35.1]	2.29 [58.2]	1.85 [47.0]	2.23 [56.6]
24	1.500 [38.10]	1.627 [41.33] 1.613 [40.97]	1.800 [45.72]	1.08 [27.4]	1.44 [36.6]	2.42 [61.5]	1.92 [48.8]	2.23 [56.6]

Raychem Adapters
CUSTOMER DRAWING

If this document is printed it becomes uncontrolled. Check for the latest revision

SIZE	CODE IDENT. NO.	DWG. NO.	REV
A	06090	TXR54	J
DO NOT SCALE THIS DWG		CAD NAME txr54_3_j_cd_j	SHEET 3 OF 3

Компания «Life Electronics» занимается поставками электронных компонентов импортного и отечественного производства от производителей и со складов крупных дистрибьюторов Европы, Америки и Азии.

С конца 2013 года компания активно расширяет линейку поставок компонентов по направлению коаксиальный кабель, кварцевые генераторы и конденсаторы (керамические, пленочные, электролитические), за счёт заключения дистрибьюторских договоров

Мы предлагаем:

- Конкуренеспособные цены и скидки постоянным клиентам.
- Специальные условия для постоянных клиентов.
- Подбор аналогов.
- Поставку компонентов в любых объемах, удовлетворяющих вашим потребностям.
- Приемлемые сроки поставки, возможна ускоренная поставка.
- Доставку товара в любую точку России и стран СНГ.
- Комплексную поставку.
- Работу по проектам и поставку образцов.
- Формирование склада под заказчика.
- Сертификаты соответствия на поставляемую продукцию (по желанию клиента).
- Тестирование поставляемой продукции.
- Поставку компонентов, требующих военную и космическую приемку.
- Входной контроль качества.
- Наличие сертификата ISO.

В составе нашей компании организован Конструкторский отдел, призванный помогать разработчикам, и инженерам.

Конструкторский отдел помогает осуществить:

- Регистрацию проекта у производителя компонентов.
- Техническую поддержку проекта.
- Защиту от снятия компонента с производства.
- Оценку стоимости проекта по компонентам.
- Изготовление тестовой платы монтаж и пусконаладочные работы.



Тел: +7 (812) 336 43 04 (многоканальный)
Email: org@lifeelectronics.ru