

---

## STEP-UP DC/DC CONTROLLER

---

NO.EA-088-0604

### OUTLINE

The R1211x Series are CMOS-based PWM step-up DC/DC converter controllers with low supply current.

Each of the R1211x Series consists of an oscillator, a PWM control circuit, a reference voltage unit, an error amplifier, a reference current unit, a protection circuit, and an under voltage lockout (UVLO) circuit. A low ripple, high efficiency step-up DC/DC converter can be composed of this IC with some external components, or an inductor, a diode, a power MOSFET, divider resistors, and capacitors.

Phase compensation has been made internally in the R1211x002B/D Series, while phase compensation can be made externally as for R1211x002A/C Series. B/D version has stand-by mode.

Max duty cycle is internally fixed typically at 90%. Soft start function is built-in, and Soft-starting time is set typically at 9ms(A/B, 700kHz version) or 10.5ms(C/D, 300kHz version). As for the protection circuit, after the soft-starting time, if the maximum duty cycle is continued for a certain period, the R1211x Series latch the external driver with its off state, or Latch-type protection circuit works.

The delay time for latch the state can be set with an external capacitor.

To release the protection circuit, restart with power-on (Voltage supplier is equal or less than UVLO detector threshold level), or once after making the circuit be stand-by with chip enable pin and enable the circuit again.

### FEATURES

- Standby Current ..... Typ. 0 $\mu$ A (for B/D version)
- Input Voltage Range ..... 2.5V to 6.0V
- Built-in Latch-type Protection Function (Output Delay Time can be set with an external capacitor)
- Two Options of Basic Oscillator Frequency ..... 300kHz, 700kHz
- Max Duty Cycle ..... Typ. 90%
- High Reference Voltage Accuracy .....  $\pm 1.5\%$
- U.V.L.O. Threshold level ..... Typ. 2.2V (Hysteresis Typ. 0.13V)
- Small Packages ..... SOT-23-6W or thin (package height Max. 0.85mm) SON-6

### APPLICATIONS

- Constant Voltage Power Source for portable equipment.
- Constant Voltage Power Source for LCD and CCD.

## BLOCK DIAGRAMS

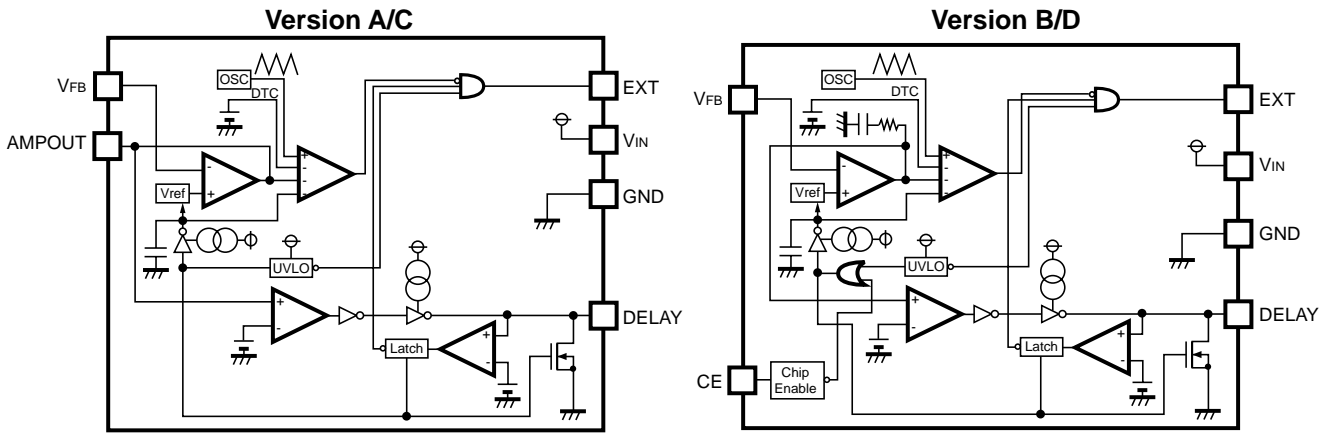

## SELECTION GUIDE

In the R1211x Series, the oscillator frequency, the optional function, and the package type for the ICs can be selected at the user's request.

The selection can be made with designating the part number as shown below;

R1211x002x-TR ←Part Number  
                   ↑          ↑  
                   a          b

Code	Contents
a	Designation of Package Type: D: SON-6 N: SOT23-6W
b	Designation of Optional Function A : 700kHz, with AMPOUT pin (External Phase Compensation Type) B : 700kHz, with CE pin (Internal Phase Compensation Type, with Stand-by) C : 300kHz, with AMPOUT pin (External Phase Compensation Type) D : 300kHz, with CE pin (Internal Phase Compensation Type, with Stand-by)

## PIN CONFIGURATIONS

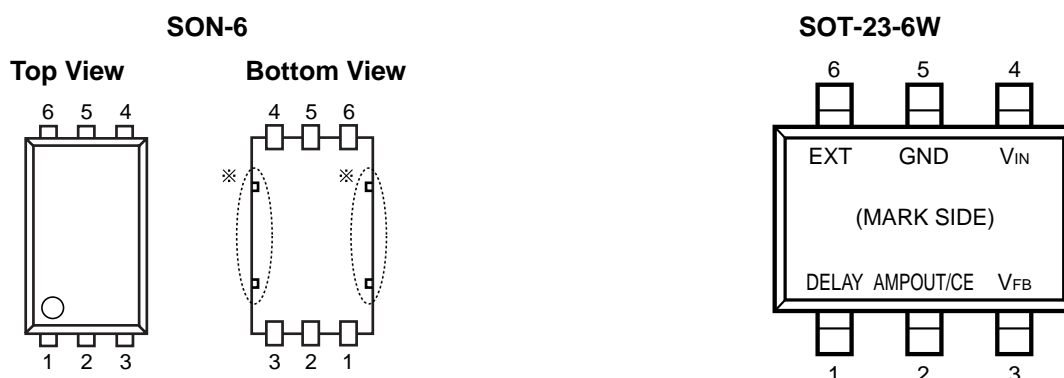

## PIN DESCRIPTIONS

Pin No		Symbol	Pin Description
SON6	SOT23-6W		
1	1	DELAY	Pin for External Capacitor (for Setting Output Delay of Protection)
2	5	GND	Ground Pin
3	6	EXT	External FET Drive Pin (CMOS Output)
4	4	V <sub>IN</sub>	Power Supply Pin
5	3	V <sub>FB</sub>	Feedback Pin for monitoring Output Voltage
6	2	AMPOUT or CE	Amplifier Output Pin(A/C Version) or Chip Enable Pin(B/D Version, Active at "H")

\* Tab in the  parts have GND level. (They are connected to the reverse side of this IC.)

Do not connect to other wires or land patterns.

## ABSOLUTE MAXIMUM RATINGS

Symbol	Item	Rating	Unit
V <sub>IN</sub>	V <sub>IN</sub> Pin Voltage	6.5	V
V <sub>EXT</sub>	EXT Pin Output Voltage	-0.3 ~ V <sub>IN</sub> +0.3	V
V <sub>DLY</sub>	DELAY Pin Voltage	-0.3 ~ V <sub>IN</sub> +0.3	V
V <sub>AMP</sub>	AMPOUT Pin Voltage	-0.3 ~ V <sub>IN</sub> +0.3	V
V <sub>CE</sub>	CE Pin Input Voltage	-0.3 ~ V <sub>IN</sub> +0.3	V
V <sub>FB</sub>	V <sub>FB</sub> Pin Voltage	-0.3 ~ V <sub>IN</sub> +0.3	V
I <sub>AMP</sub>	AMPOUT Pin Current	±10	mA
I <sub>EXT</sub>	EXT Pin Inductor Drive Output Current	±50	mA
P <sub>D</sub>	Power Dissipation (SOT-23-6W)*	430	
	Power Dissipation (SON-6)*	500	mW
T <sub>opt</sub>	Operating Temperature Range	-40 ~ +85	°C
T <sub>stg</sub>	Storage Temperature Range	-55 ~ +125	°C

\* ) For Power Dissipation, please refer to PACKAGE INFORMATION to be described.

## ELECTRICAL CHARACTERISTICS

## • R1211x002A

T<sub>opt</sub>=25°C

Symbol	Item	Conditions	Min.	Typ.	Max.	Unit
V <sub>IN</sub>	Operating Input Voltage		2.5		6.0	V
V <sub>FB</sub>	V <sub>FB</sub> Voltage Tolerance	V <sub>IN</sub> =3.3V	0.985	1.000	1.015	V
ΔV <sub>FB</sub> /ΔT	V <sub>FB</sub> Voltage Temperature Coefficient	-40°C ≤ T <sub>opt</sub> ≤ 85°C		±150		ppm/°C
I <sub>FB</sub>	V <sub>FB</sub> Input Current	V <sub>IN</sub> =6V, V <sub>FB</sub> =0V or 6V	-0.1		0.1	μA
f <sub>OSC</sub>	Oscillator Frequency	V <sub>IN</sub> =3.3V, V <sub>DLY</sub> =V <sub>FB</sub> =0V	595	700	805	kHz
Δf <sub>OSC</sub> /ΔT	Oscillator Frequency Temperature Coefficient	-40°C ≤ T <sub>opt</sub> ≤ 85°C		±1.4		kHz/°C
I <sub>DD1</sub>	Supply Current 1	V <sub>IN</sub> =6V, V <sub>DLY</sub> =V <sub>FB</sub> =0V, EXT at no load		600	900	μA
maxdty	Maximum Duty Cycle	V <sub>IN</sub> =3.3V, EXT "H" side	82	90	94	%
R <sub>EXTH</sub>	EXT "H" ON Resistance	V <sub>IN</sub> =3.3V, I <sub>EXT</sub> =-20mA		5	10	Ω
R <sub>EXTL</sub>	EXT "L" ON Resistance	V <sub>IN</sub> =3.3V, I <sub>EXT</sub> =20mA		3	6	Ω
I <sub>DLY1</sub>	Delay Pin Charge Current	V <sub>IN</sub> =3.3V, V <sub>DLY</sub> =V <sub>FB</sub> =0V	2.5	5.0	7.5	μA
I <sub>DLY2</sub>	Delay Pin Discharge Current	V <sub>IN</sub> =V <sub>FB</sub> =2.5V, V <sub>DLY</sub> =0.1V	2.5	5.5	9.0	mA
V <sub>DLY</sub>	Delay Pin Detector Threshold	V <sub>IN</sub> =3.3V, V <sub>FB</sub> =0V, V <sub>DLY</sub> =0V→2V	0.95	1.00	1.05	V
T <sub>START</sub>	Soft-start Time	V <sub>IN</sub> =3.3V at 90% of rising edge	4.5	9.0	13.5	ms
V <sub>UVLO1</sub>	UVLO Detector Threshold	V <sub>IN</sub> =3.3V→0V, V <sub>DLY</sub> =V <sub>FB</sub> =0V	2.1	2.2	2.3	V
V <sub>UVLO2</sub>	UVLO Detector Hysteresis	V <sub>IN</sub> =0V→3.3V, V <sub>DLY</sub> =V <sub>FB</sub> =0V	0.08	0.13	0.18	V
I <sub>AMP1</sub>	AMP "H" Output Current	V <sub>IN</sub> =3.3V, V <sub>AMP</sub> =1V, V <sub>FB</sub> =0.9V	0.45	0.90	1.50	mA
I <sub>AMP2</sub>	AMP "L" Output Current	V <sub>IN</sub> =3.3V, V <sub>AMP</sub> =1V, V <sub>FB</sub> =1.1V	30	60	90	μA

## • R1211x002B

T<sub>opt</sub>=25°C

Symbol	Item	Conditions	Min.	Typ.	Max.	Unit
V <sub>IN</sub>	Operating Input Voltage		2.5		6.0	V
V <sub>FB</sub>	V <sub>FB</sub> Voltage Tolerance	V <sub>IN</sub> =3.3V	0.985	1.000	1.015	V
ΔV <sub>FB</sub> /ΔT	V <sub>FB</sub> Voltage Temperature Coefficient	-40°C ≤ T <sub>opt</sub> ≤ 85°C		±150		ppm/°C
I <sub>FB</sub>	VFB Input Current	V <sub>IN</sub> =6V, V <sub>FB</sub> =0V or 6V	-0.1		0.1	μA
f <sub>OSC</sub>	Oscillator Frequency	V <sub>IN</sub> =3.3V, V <sub>DLY</sub> =V <sub>FB</sub> =0V	595	700	805	kHz
Δf <sub>OSC</sub> /ΔT	Oscillator Frequency Temperature Coefficient	-40°C ≤ T <sub>opt</sub> ≤ 85°C		±1.4		kHz/°C
I <sub>DD1</sub>	Supply Current 1	V <sub>IN</sub> =6V, V <sub>DLY</sub> =V <sub>FB</sub> =0V, EXT at no load		600	900	μA
maxdty	Maximum Duty Cycle	V <sub>IN</sub> =3.3V, EXT "H" side	82	90	94	%
R <sub>EXTH</sub>	EXT "H" ON Resistance	V <sub>IN</sub> =3.3V, I <sub>EXT</sub> =-20mA		5	10	Ω
R <sub>EXTL</sub>	EXT "L" ON Resistance	V <sub>IN</sub> =3.3V, I <sub>EXT</sub> =20mA		3	6	Ω
I <sub>DLY1</sub>	Delay Pin Charge Current	V <sub>IN</sub> =3.3V, V <sub>DLY</sub> =V <sub>FB</sub> =0V	2.5	5.0	7.5	μA
I <sub>DLY2</sub>	Delay Pin Discharge Current	V <sub>IN</sub> =V <sub>FB</sub> =2.5V, V <sub>DLY</sub> =0.1V	2.5	5.5	9.0	mA
V <sub>DLY</sub>	Delay Pin Detector Threshold	V <sub>IN</sub> =3.3V, V <sub>FB</sub> =0V, V <sub>DLY</sub> =0V→2V	0.95	1.00	1.05	V
T <sub>START</sub>	Soft-start Time	V <sub>IN</sub> =3.3V	4.5	9.0	13.5	ms
V <sub>UVLO1</sub>	UVLO Detector Threshold	V <sub>IN</sub> =3.3V→0V, V <sub>DLY</sub> =V <sub>FB</sub> =0V	2.1	2.2	2.3	V
V <sub>UVLO2</sub>	UVLO Detector Hysteresis	V <sub>IN</sub> =0V→3.3V, V <sub>DLY</sub> =V <sub>FB</sub> =0V	0.08	0.13	0.18	V
I <sub>STB</sub>	Standby Current	V <sub>IN</sub> =6V, V <sub>CE</sub> =0V		0	1	μA
I <sub>CEH</sub>	CE "H" Input Current	V <sub>IN</sub> =6V, V <sub>CE</sub> =6V	-0.5		0.5	μA
I <sub>CEL</sub>	CE "L" Input Current	V <sub>IN</sub> =6V, V <sub>CE</sub> =0V	-0.5		0.5	μA
V <sub>CEH</sub>	CE "H" Input Voltage	V <sub>IN</sub> =6V, V <sub>CE</sub> =0V→6V	1.5			V
V <sub>CEL</sub>	CE "L" Input Voltage	V <sub>IN</sub> =2.5V, V <sub>CE</sub> =2V→0V			0.3	V

## R1211x

### • R1211x002C

T<sub>opt</sub>=25°C

Symbol	Item	Conditions	Min.	Typ.	Max.	Unit
V <sub>IN</sub>	Operating Input Voltage		2.5		6.0	V
V <sub>FB</sub>	V <sub>FB</sub> Voltage Tolerance	V <sub>IN</sub> =3.3V	0.985	1.000	1.015	V
ΔV <sub>FB</sub> /ΔT	V <sub>FB</sub> Voltage Temperature Coefficient	-40°C ≤ T <sub>opt</sub> ≤ 85°C		±150		ppm/°C
I <sub>FB</sub>	VFB Input Current	V <sub>IN</sub> =6V, V <sub>FB</sub> =0V or 6V	-0.1		0.1	μA
f <sub>OSC</sub>	Oscillator Frequency	V <sub>IN</sub> =3.3V, V <sub>DLY</sub> =V <sub>FB</sub> =0V	240	300	360	kHz
Δf <sub>OSC</sub> /ΔT	Oscillator Frequency Temperature Coefficient	-40°C ≤ T <sub>opt</sub> ≤ 85°C		±0.6		kHz/°C
I <sub>DD1</sub>	Supply Current 1	V <sub>IN</sub> =6V, V <sub>DLY</sub> =V <sub>FB</sub> =0V, EXT at no load		300	500	μA
maxdty	Maximum Duty Cycle	V <sub>IN</sub> =3.3V, EXT "H" side	82	90	94	%
R <sub>EXTH</sub>	EXT "H" ON Resistance	V <sub>IN</sub> =3.3V, I <sub>EXT</sub> =-20mA		5	10	Ω
R <sub>EXTL</sub>	EXT "L" ON Resistance	V <sub>IN</sub> =3.3V, I <sub>EXT</sub> =20mA		3	6	Ω
I <sub>DLY1</sub>	Delay Pin Charge Current	V <sub>IN</sub> =3.3V, V <sub>DLY</sub> =V <sub>FB</sub> =0V	2.0	4.5	7.0	μA
I <sub>DLY2</sub>	Delay Pin Discharge Current	V <sub>IN</sub> =V <sub>FB</sub> =2.5V, V <sub>DLY</sub> =0.1V	2.5	5.5	9.0	mA
V <sub>DLY</sub>	Delay Pin Detector Threshold	V <sub>IN</sub> =3.3V, V <sub>FB</sub> =0V, V <sub>DLY</sub> =0V→2V	0.95	1.00	1.05	V
T <sub>START</sub>	Soft-start Time	V <sub>IN</sub> =3.3V	5.0	10.5	16.0	ms
V <sub>UVLO1</sub>	UVLO Detector Threshold	V <sub>IN</sub> =3.3V→0V, V <sub>DLY</sub> =V <sub>FB</sub> =0V	2.1	2.2	2.3	V
V <sub>UVLO2</sub>	UVLO Detector Hysteresis	V <sub>IN</sub> =0V→3.3V, V <sub>DLY</sub> =V <sub>FB</sub> =0V	0.08	0.13	0.18	V
I <sub>AMP1</sub>	AMP "H" Output Current	V <sub>IN</sub> =3.3V, V <sub>AMP</sub> =1V, V <sub>FB</sub> =0.9V	0.45	0.90	1.50	mA
I <sub>AMP2</sub>	AMP "L" Output Current	V <sub>IN</sub> =3.3V, V <sub>AMP</sub> =1V, V <sub>FB</sub> =1.1V	25	50	75	μA

## • R1211x002D

T<sub>opt</sub>=25°C

Symbol	Item	Conditions	Min.	Typ.	Max.	Unit
V <sub>IN</sub>	Operating Input Voltage		2.5		6.0	V
V <sub>FB</sub>	V <sub>FB</sub> Voltage Tolerance	V <sub>IN</sub> =3.3V	0.985	1.000	1.015	V
ΔV <sub>FB</sub> /ΔT	V <sub>FB</sub> Voltage Temperature Coefficient	-40°C ≤ T <sub>opt</sub> ≤ 85°C		±150		ppm/°C
I <sub>FB</sub>	V <sub>FB</sub> Input Current	V <sub>IN</sub> =6V, V <sub>FB</sub> =0V or 6V	-0.1		0.1	μA
f <sub>OSC</sub>	Oscillator Frequency	V <sub>IN</sub> =3.3V, V <sub>DLY</sub> =V <sub>FB</sub> =0V	240	300	360	kHz
Δf <sub>OSC</sub> /ΔT	Oscillator Frequency Temperature Coefficient	-40°C ≤ T <sub>opt</sub> ≤ 85°C		±0.6		kHz/°C
I <sub>DD1</sub>	Supply Current 1	V <sub>IN</sub> =6V, V <sub>DLY</sub> =V <sub>FB</sub> =0V, EXT at no load		300	500	μA
maxdty	Maximum Duty Cycle	V <sub>IN</sub> =3.3V, EXT "H" side	82	90	94	%
R <sub>EXTH</sub>	EXT "H" ON Resistance	V <sub>IN</sub> =3.3V, I <sub>EXT</sub> =-20mA		5	10	Ω
R <sub>EXTL</sub>	EXT "L" ON Resistance	V <sub>IN</sub> =3.3V, I <sub>EXT</sub> =20mA		3	6	Ω
I <sub>DLY1</sub>	Delay Pin Charge Current	V <sub>IN</sub> =3.3V, V <sub>DLY</sub> =V <sub>FB</sub> =0V	2.0	4.5	7.0	μA
I <sub>DLY2</sub>	Delay Pin Discharge Current	V <sub>IN</sub> =V <sub>FB</sub> =2.5V, V <sub>DLY</sub> =0.1V	2.5	5.5	9.0	mA
V <sub>DLY</sub>	Delay Pin Detector Threshold	V <sub>IN</sub> =3.3V, V <sub>FB</sub> =0V, V <sub>DLY</sub> =0V→2V	0.95	1.00	1.05	V
T <sub>START</sub>	Soft-start Time	V <sub>IN</sub> =3.3V	5.0	10.5	16.0	ms
V <sub>UVLO1</sub>	UVLO Detector Threshold	V <sub>IN</sub> =3.3V→0V, V <sub>DLY</sub> =V <sub>FB</sub> =0V	2.1	2.2	2.3	V
V <sub>UVLO2</sub>	UVLO Detector Hysteresis	V <sub>IN</sub> =0V→3.3V, V <sub>DLY</sub> =V <sub>FB</sub> =0V	0.08	0.13	0.18	V
I <sub>STB</sub>	Standby Current	V <sub>IN</sub> =6V, V <sub>CE</sub> =0V		0	1	μA
I <sub>CEH</sub>	CE "H" Input Current	V <sub>IN</sub> =6V, V <sub>CE</sub> =6V	-0.5		0.5	μA
I <sub>CEL</sub>	CE "L" Input Current	V <sub>IN</sub> =6V, V <sub>CE</sub> =0V	-0.5		0.5	μA
V <sub>CEH</sub>	CE "H" Input Voltage	V <sub>IN</sub> =6V, V <sub>CE</sub> =0V→6V	1.5			V
V <sub>CEL</sub>	CE "L" Input Voltage	V <sub>IN</sub> =2.5V, V <sub>CE</sub> =2V→0V			0.3	V

## TYPICAL APPLICATIONS AND TECHNICAL NOTES

## &lt;R1211x002A/R1211x002C&gt;

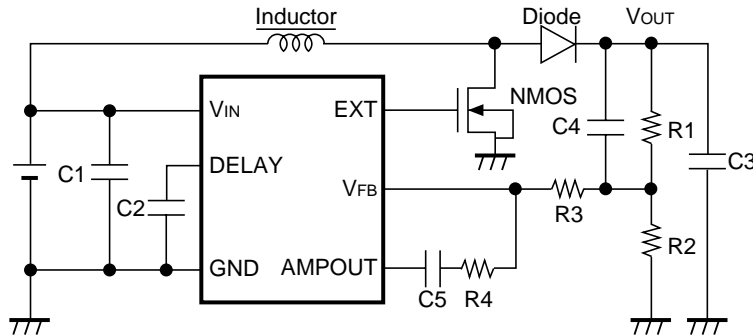

NMOS : IRF7601 (International Rectifier)  
 Inductor : LDR655312T-100 10 $\mu$ H (TDK) for R1211x002A  
           : LDR655312T-220 22 $\mu$ H (TDK) for R1211x002C  
 Diode : CRS02 (Toshiba)

C1 : 4.7 $\mu$ F (Ceramic)                   R1 : Output Voltage Setting Resistor 1  
 C2 : 0.22 $\mu$ F (Ceramic)               R2 : Output Voltage Setting Resistor 2  
 C3 : 10 $\mu$ F (Ceramic)                 R3 : 30k $\Omega$   
 C4 : 680pF (Ceramic)                R4 : 30k $\Omega$   
 C5 : 2200pF (Ceramic)

## &lt;R1211x002B/R1211x002D&gt;

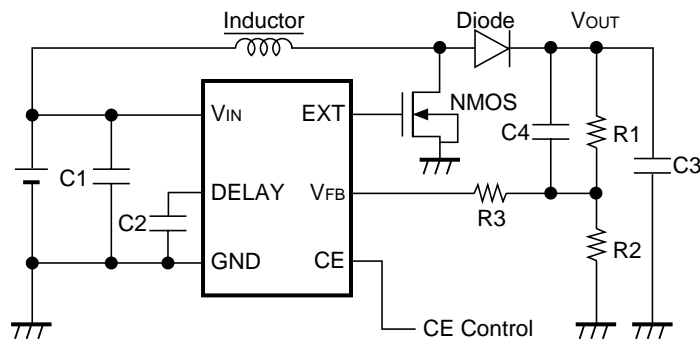

NMOS : IRF7601 (International Rectifier)  
 Inductor : LDR655312T-100 10 $\mu$ H (TDK) for R1211x002B  
           : LDR655312T-220 22 $\mu$ H (TDK) for R1211x002D  
 Diode : CRS02 (Toshiba)

C1 : 4.7 $\mu$ F (Ceramic)                   R1 : Setting Output Voltage Resistor 1  
 C2 : 0.22 $\mu$ F (Ceramic)               R2 : Setting Output Voltage Resistor 2  
 C3 : 10 $\mu$ F (Ceramic)                 R3 : 30k $\Omega$   
 C4 : 680pF (Ceramic)

**[Note]**

These example circuits may be applied to the output voltage requirement is 15V or less. If the output voltage requirement is 15V or more, ratings of NMOS and diode as shown above is over the limit, therefore, choose other external components.



Use a 1 $\mu$ F or more capacitance value of bypass capacitor between V<sub>IN</sub> pin and GND, C1 as shown in the typical applications above.

- In terms of the capacitor for setting delay time of the latch protection, C2 as shown in typical applications of the previous page, connect between Delay pin and GND pin of the IC with the minimum wiring distance.
- Connect a 1 $\mu$ F or more value of capacitor between V<sub>OUT</sub> and GND, C3 as shown in typical applications of the previous page. (Recommended value is from 10 $\mu$ F to 22 $\mu$ F.) If the operation of the composed DC/DC converter may be unstable, use a tantalum type capacitor instead of ceramic type.
- Connect a capacitor between V<sub>OUT</sub> and the dividing point, C4 as shown in typical applications of the previous page. The capacitance value of C4 depends on divider resistors for output voltage setting. Typical value is between 100pF and 1000pF.

- Output Voltage can be set with divider resistors for voltage setting, R1 and R2 as shown in typical applications of the previous page. Refer to the next formula.

$$\text{Output Voltage} = V_{FB} \times (R1+R2)/R2$$

R1+R2=100k $\Omega$  is recommended range of resistances.

- The operation of Latch protection circuit is as follows: When the IC detects maximum duty cycle, charge to an external capacitor, C2 of DELAY pin starts. And maximum duty cycle continues and the voltage of DELAY pin reaches delay voltage detector threshold, V<sub>DLY</sub>, outputs "L" to EXT pin and turns off the external power MOSFET.

To release the latch protection operation, make the IC be standby mode with CE pin and make it active in terms of B/D version. Otherwise, restart with power on.

The delay time of latch protection can be calculated with C2, V<sub>DLY</sub>, and Delay Pin Charge Current, I<sub>DLY1</sub>, as in the next formula.

$$t=C2 \times V_{DLY} / I_{DLY1}$$

Once after the maximum duty is detected and released before delay time, charge to the capacitor is halt and delay pin outputs "L".

- As for R1211x002A/C version, the values and positioning of C4, C5, R3, and R4 shown in the above diagram are just an example combination. These are for making phase compensation. If the spike noise of V<sub>OUT</sub> may be large, the spike noise may be picked into V<sub>FB</sub> pin and make the operation unstable. In this case, a resistor R3, shown in typical applications of the previous page. The recommended resistance value of R3 is in the range from 10k $\Omega$  to 50k $\Omega$ . Then, noise level will be decreased.

- As for R1211x002B/D version, EXT pin outputs GND level at standby mode.
- Select the Power MOSFET, the diode, and the inductor within ratings (Voltage, Current, Power) of this IC. Choose the power MOSFET with low threshold voltage depending on Input Voltage to be able to turn on the FET completely. Choose the diode with low V<sub>F</sub> such as Schottky type with low reverse current I<sub>R</sub>, and with fast switching speed. When an external transistor is switching, spike voltage may be generated caused by an inductor, therefore recommended voltage tolerance of capacitor connected to V<sub>OUT</sub> is three times of setting voltage or more.

\* The performance of power circuit with using this IC depends on external components. Choose the most suitable components for your application.

## Output Current and Selection of External Components

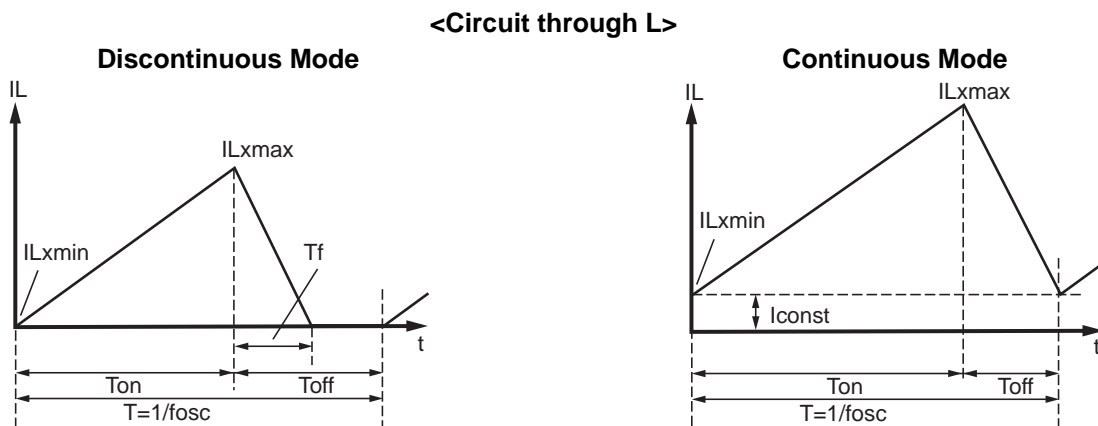
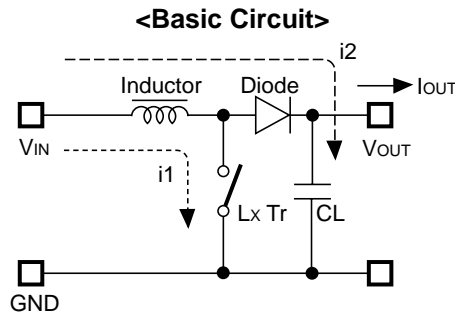

There are two modes, or discontinuous mode and continuous mode for the PWM step-up switching regulator depending on the continuous characteristic of inductor current.

During on time of the transistor, when the voltage added on to the inductor is described as  $V_{IN}$ , the current is  $V_{IN} \times t / L$ . Therefore, the electric power,  $P_{ON}$ , which is supplied with input side, can be described as in next formula.

$$P_{ON} = \int_0^{T_{on}} V_{IN}^2 \times t / L \, dt \dots\dots\dots \text{Formula 1}$$

With the step-up circuit, electric power is supplied from power source also during off time. In this case, input current is described as  $(V_{OUT} - V_{IN}) \times t / L$ , therefore electric power,  $P_{OFF}$  is described as in next formula.

$$P_{OFF} = \int_0^{T_{f}} V_{IN} \times (V_{OUT} - V_{IN}) \times t / L \, dt \dots\dots\dots \text{Formula 2}$$

In this formula,  $T_f$  means the time of which the energy saved in the inductance is being emitted. Thus average electric power,  $P_{AV}$  is described as in the next formula.

$$P_{AV} = 1 / (T_{ON} + T_{OFF}) \times \left\{ \int_0^{T_{on}} V_{IN}^2 \times t / L \, dt + \int_0^{T_{f}} V_{IN} \times (V_{OUT} - V_{IN}) \times t / L \, dt \right\} \dots\dots\dots \text{Formula 3}$$

In PWM control, when  $T_f = T_{off}$  is true, the inductor current becomes continuous, then the operation of switching regulator becomes continuous mode.

In the continuous mode, the deviation of the current is equal between on time and off time.

$$V_{IN} \times T_{ON} / L = (V_{OUT} - V_{IN}) \times T_{off} / L \dots\dots\dots \text{Formula 4}$$

Further, the electric power,  $P_{AV}$  is equal to output electric power,  $V_{OUT} \times I_{OUT}$ , thus,

$$I_{OUT} = f_{OSC} \times V_{IN}^2 \times T_{ON}^2 / \{2 \times L \times (V_{OUT} - V_{IN})\} = V_{IN}^2 \times T_{ON} / (2 \times L \times V_{OUT}) \dots\dots\dots \text{Formula 5}$$

When  $I_{OUT}$  becomes more than formula 5, the current flows through the inductor, then the mode becomes continuous. The continuous current through the inductor is described as  $I_{CONST}$ , then,

$$I_{OUT} = f_{OSC} \times V_{IN}^2 \times T_{ON}^2 / \{2 \times L \times (V_{OUT} - V_{IN})\} + V_{IN} \times I_{CONST} / V_{OUT} \dots\dots\dots \text{Formula 6}$$

In this moment, the peak current,  $I_{LXMAX}$  flowing through the inductor and the driver  $T_r$  is described as follows:

$$I_{LXMAX} = I_{CONST} + V_{IN} \times T_{ON} / L \dots\dots\dots \text{Formula 7}$$

With the formula 4,6, and  $I_{LXMAX}$  is,

$$I_{LXMAX} = V_{OUT} / V_{IN} \times I_{OUT} + V_{IN} \times T_{ON} / (2 \times L) \dots\dots\dots \text{Formula 8}$$

Therefore, peak current is more than  $I_{OUT}$ . Considering the value of  $I_{LXMAX}$ , the condition of input and output, and external components should be selected.

In the formula 7, peak current  $I_{LXMAX}$  at discontinuous mode can be calculated. Put  $I_{CONST}=0$  in the formula.

The explanation above is based on the ideal calculation, and the loss caused by  $L_x$  switch and external components is not included. The actual maximum output current is between 50% and 80% of the calculation. Especially, when the  $I_{LX}$  is large, or  $V_{IN}$  is low, the loss of  $V_{IN}$  is generated with the on resistance of the switch. As for  $V_{OUT}$ ,  $V_f$  (as much as 0.3V) of the diode should be considered.

## TIMING CHART

### • R1211x002A/R1211x002C

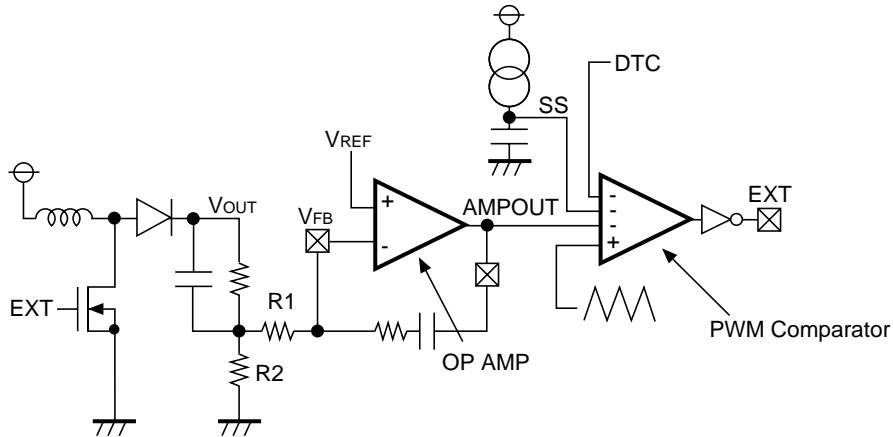

### • R1211x002B/R1211x002D

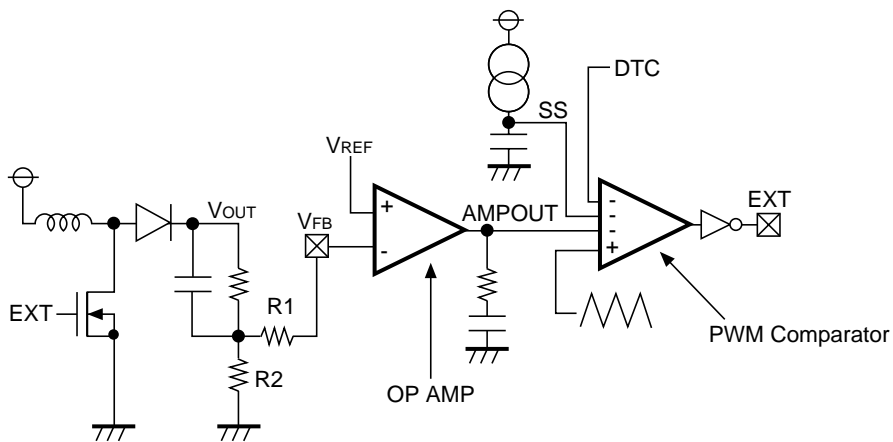

#### <Soft-start Operation>

Soft-start operation is starting from power-on as follows:

##### (Step1)

The voltage level of SS is rising gradually by constant current circuit of the IC and a capacitor.  $V_{REF}$  level which is input to OP AMP is also gradually rising.  $V_{OUT}$  is rising up to input voltage level just after the power-on, therefore,  $V_{FB}$  voltage is rising up to the setting voltage with input voltage and the ration of R1 and R2. AMPOUT is at "L", and switching does not start.

##### (Step2)

When the voltage level of SS becomes the setting voltage with the ration of R1 and R2 or more, switching operation starts.  $V_{REF}$  level gradually increases together with SS level.  $V_{OUT}$  is also rising with balancing  $V_{REF}$  and  $V_{FB}$ . Duty cycle depends on the lowest level among AMPOUT, SS, and DTC of the 4 input terminals in the PWM comparator.

**(Step3)**

When SS reaches 1V, soft-start operation finishes.  $V_{REF}$  becomes constant voltage (=1V). Then the switching operation becomes normal mode.

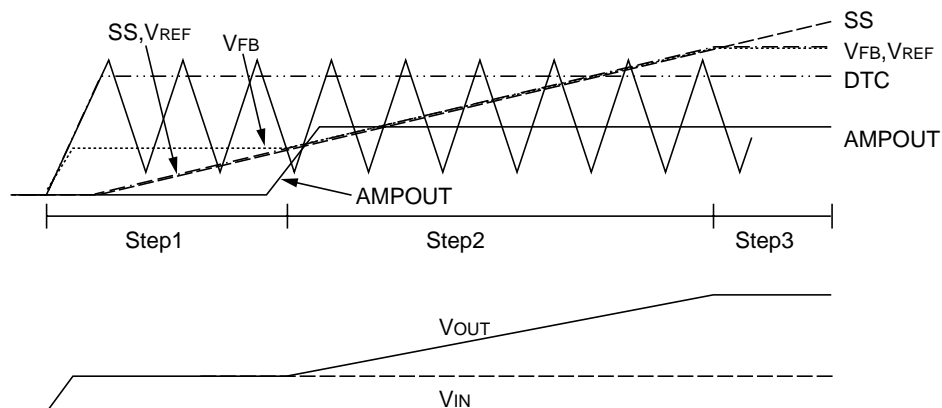
**<Latch Protection Operation>**

The operation of Latch protection circuit is as follows: When AMPOUT becomes "H" and the IC detects maximum duty cycle, charge to an external capacitor, C2 of DELAY pin starts. And maximum duty cycle continues and the voltage of DELAY pin reaches delay voltage detector threshold,  $V_{DLY}$ , outputs "L" to EXT pin and turns off the external power MOSFET.

To release the latch protection operation, make the IC be standby mode with CE pin and make it active in terms of R1211x002B/D version. Otherwise, make supply voltage down to UVLO detector threshold or lower, and make it rise up to the normal input voltage.

During the soft-start time, if the duty cycle may be the maximum, protection circuit does not work and DELAY pin is fixed at GND level.

The delay time of latch protection can be calculated with C2,  $V_{DLY}$ , and Delay Pin Charge Current,  $I_{DLY1}$ , as in the next formula.

$$t = C2 \times V_{DLY} / I_{DLY1}$$

Once after the maximum duty is detected and released before delay time, charge to the capacitor is halt and delay pin outputs "L".

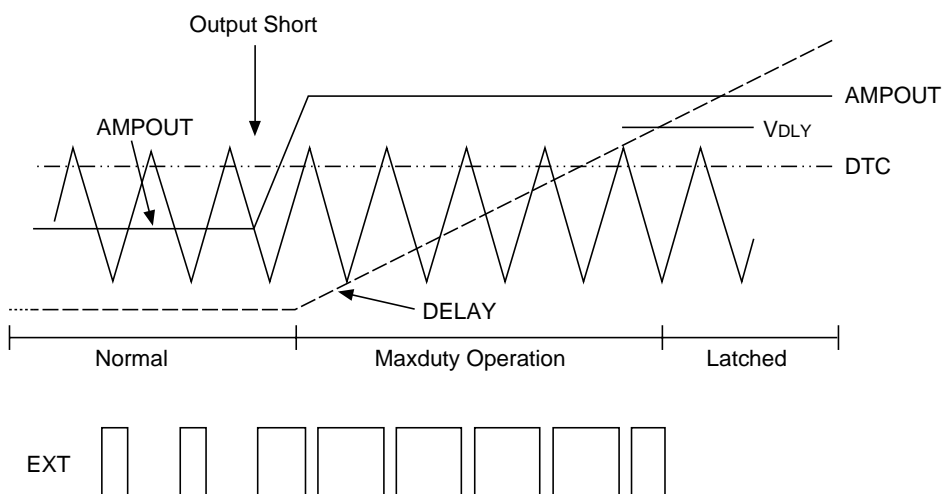

## TEST CIRCUITS

- R1211x002A/R1211x002C

**\*Oscillator Frequency, Maximum Duty Cycle,  $V_{FB}$  Voltage Test**

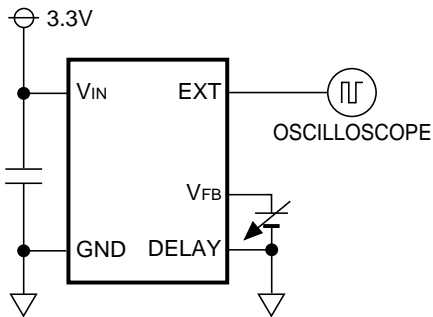

**\*Consumption Current Test**

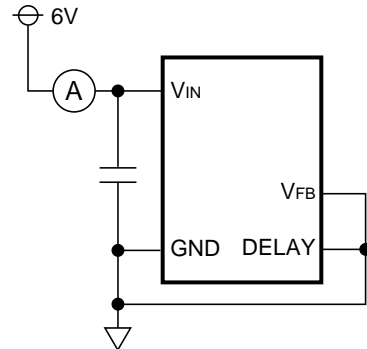

**\*EXT "H" ON Resistance**

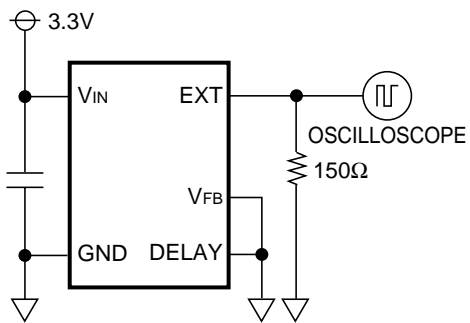

**\*EXT "L" ON Resistance**

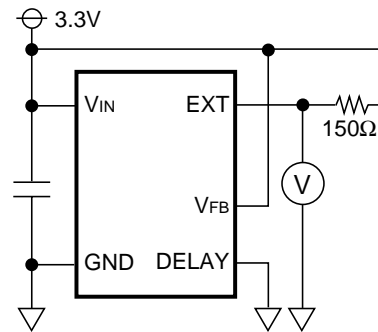

**\*DELAY Pin Charge Current**

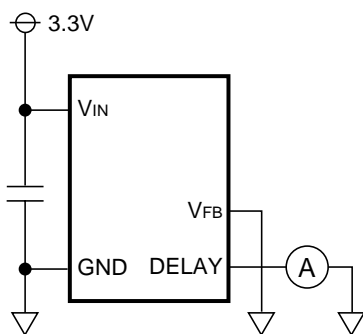

**\*DELAY Pin Discharge Current**

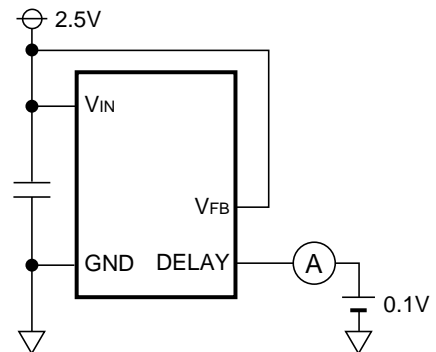

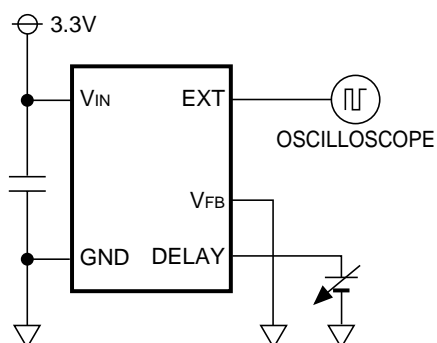
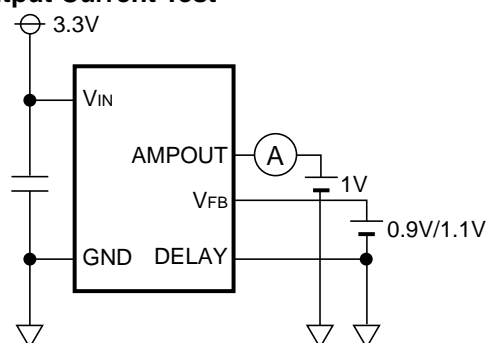
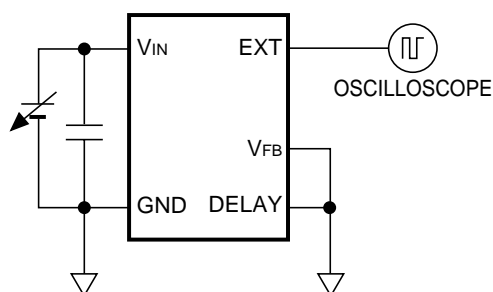
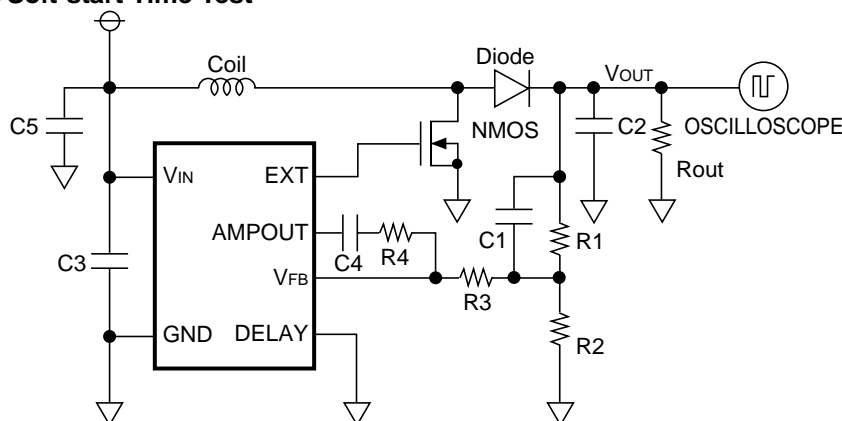
**\*DELAY Pin Detector Threshold Voltage Test****\*AMP "H" Output Current/"L"****Output Current Test****\*UVLO Detector Threshold/Hysteresis Range Test****\*Soft-start Time Test****<Components>**

Inductor (L)	: 22 $\mu$ H (TDK LDR655312T-220)
Diode (SD)	: CRS02 (Toshiba)
Capacitors	C1:680pF(Ceramic), C2:22 $\mu$ F (Tantalum)+2.2 $\mu$ F (Ceramic), C3:68 $\mu$ F (Tantalum)+2.2 $\mu$ F (Ceramic), C4:2200pF(Ceramic), C5:22 $\mu$ F(Tantalum)
NMOS Transistor	: IRF7601 (International Rectifier)
Resistors	: R1: 90k $\Omega$ , R2:10k $\Omega$ , R3:30k $\Omega$ , R4:30k $\Omega$ , Rout:1k $\Omega$ /330 $\Omega$

• R1211x002B/R1211x002D

**\*Oscillator Frequency, Maximum Duty Cycle, V<sub>FB</sub> Voltage Test**

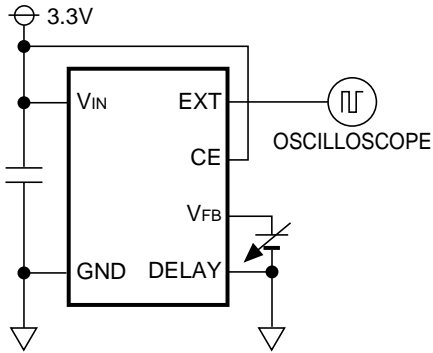

**\*Consumption Current Test**

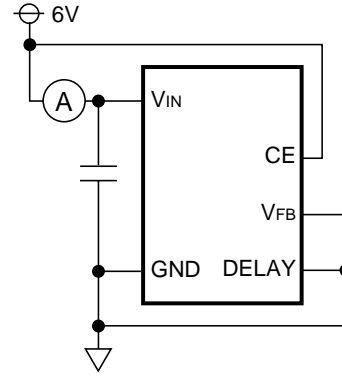

**\*EXT "H" ON Resistance**

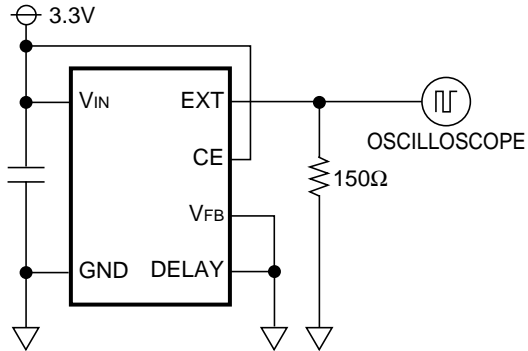

**\*EXT "L" ON Resistance**

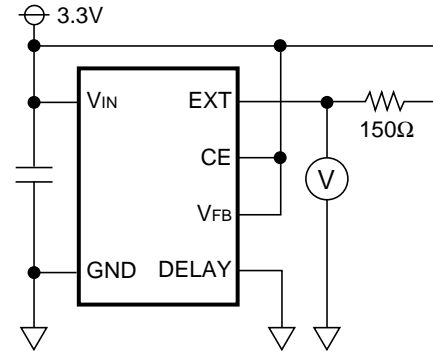

**\*DELAY Pin Charge Current**

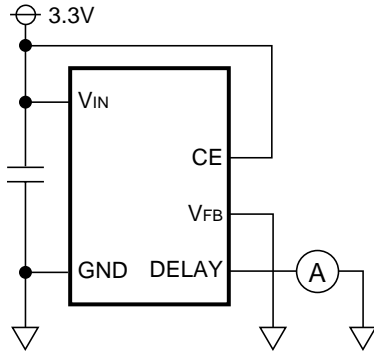

**\*DELAY Pin Discharge Current**

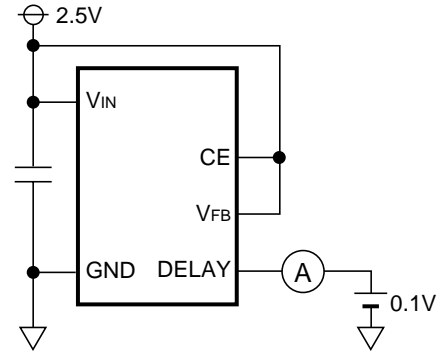

**\*DELAY Pin Detector Threshold Voltage Test**

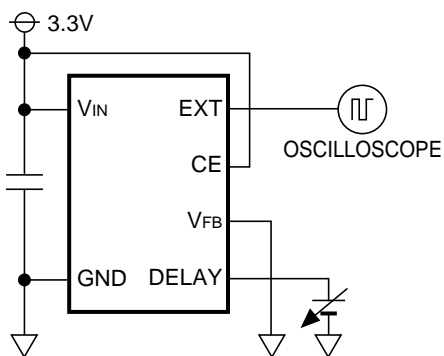

**\*Standby Current Test**

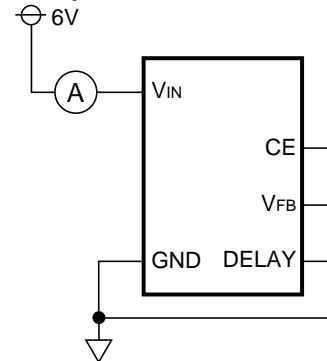



**\*UVLO Detector Threshold/  
Hysteresis Range Test**

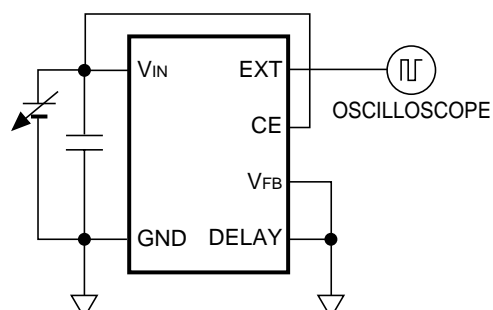

**\* CE "L" Input Current/"H" Input Current Test**

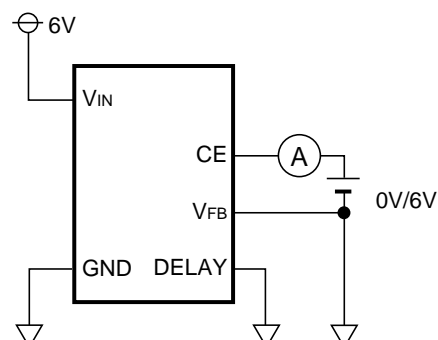

**\*CE "L" Input Voltage/"H" Input Voltage Test**

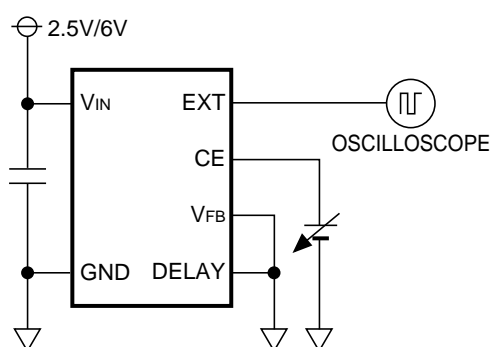

**\*Soft-start Time Test**

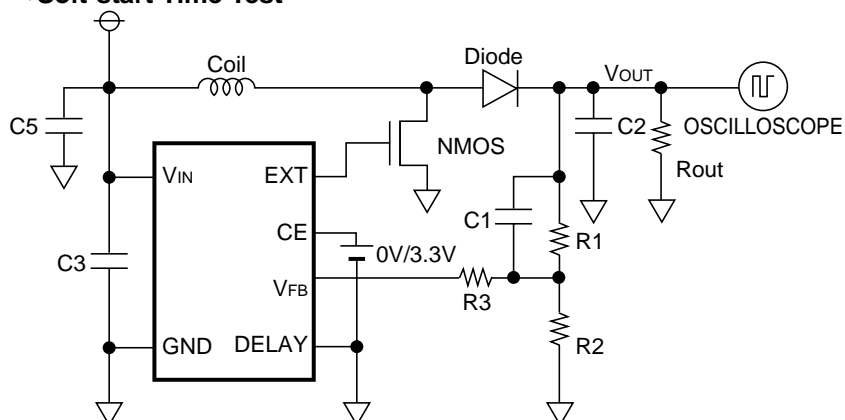

**<Components>**

Inductor (L)	: 22 $\mu$ H (TDK LDR655312T-220)
Diode (SD)	: CRS02 (Toshiba)
Capacitors	C1 : 680pF (Ceramic), C2: 22 $\mu$ F (Tantalum)+2.2 $\mu$ F (Ceramic), C3 : 68 $\mu$ F (Tantalum)+2.2 $\mu$ F (Ceramic), C5: 22 $\mu$ F (Tantalum)
NMOS Transistor	: IRF7601 (International Rectifier)
Resistors	: R1: 90k $\Omega$ , R2: 10k $\Omega$ , R3: 30k $\Omega$

# TYPICAL CHARACTERISTICS

## 1) Output Voltage vs. Output Current

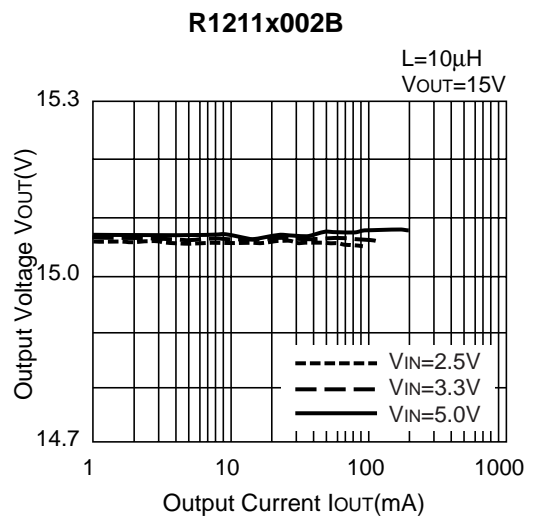
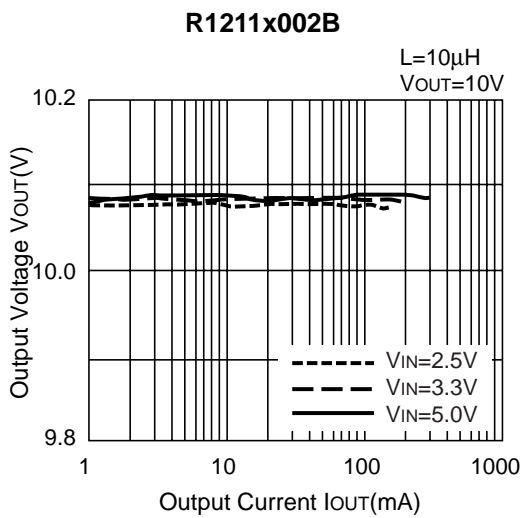
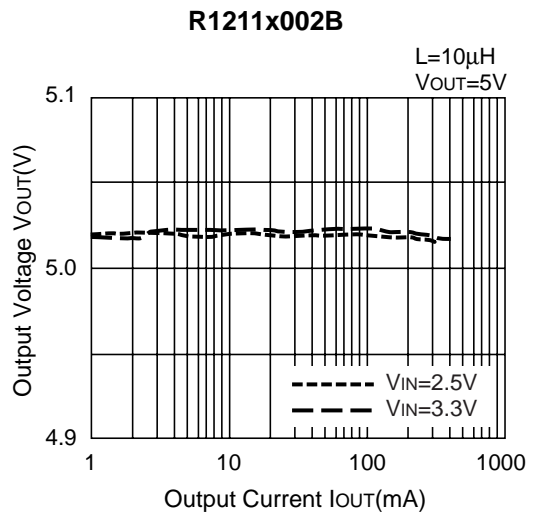
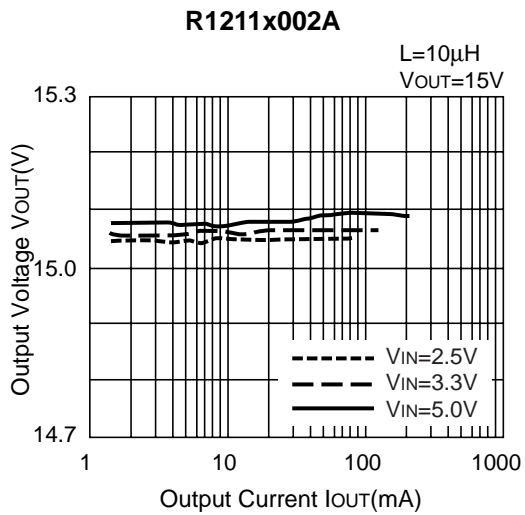
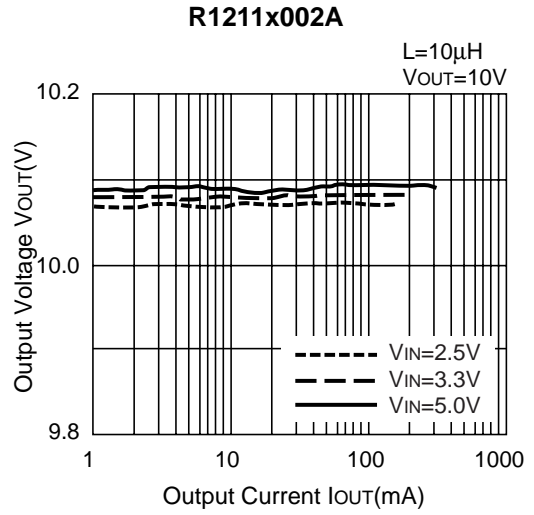
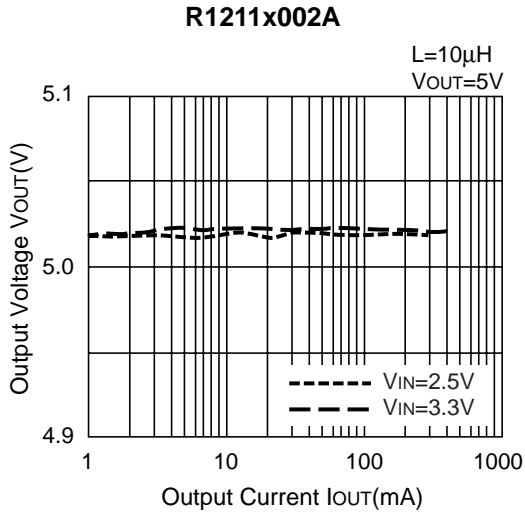

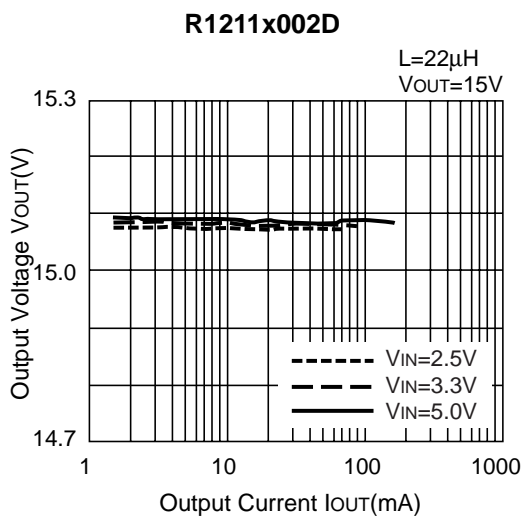
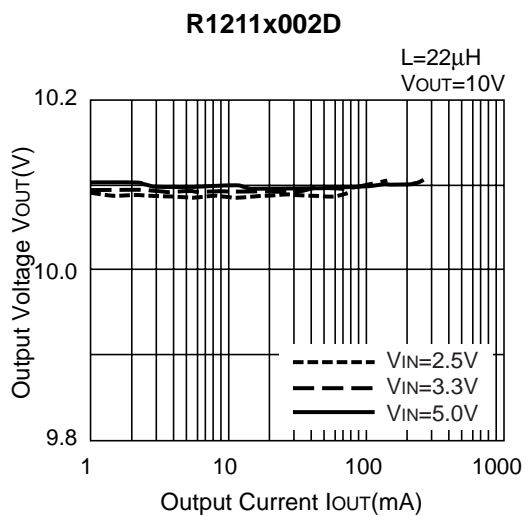
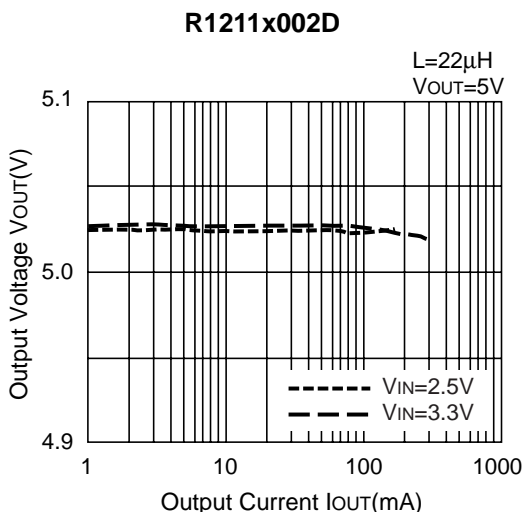
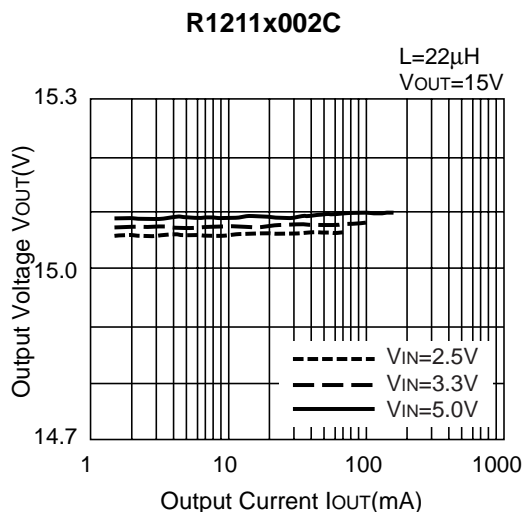
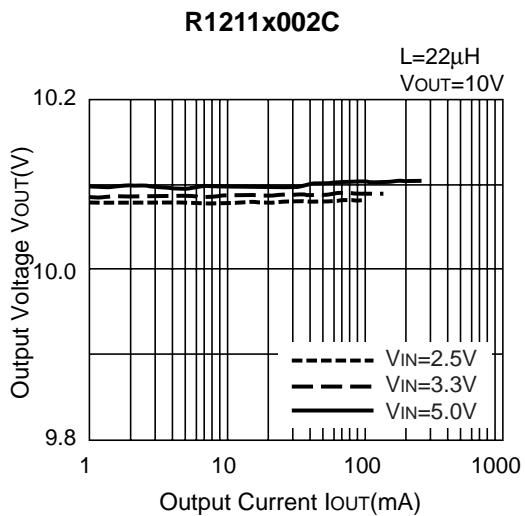
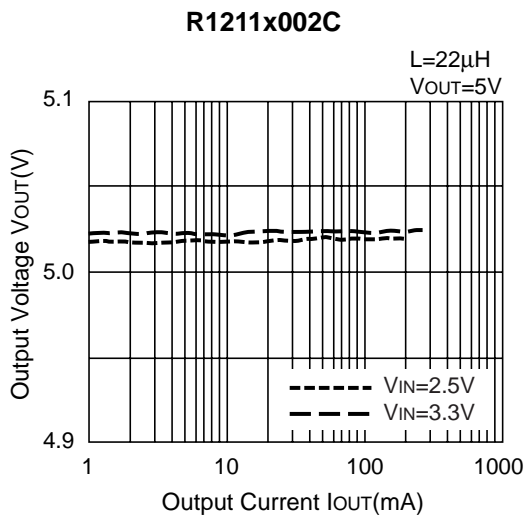

2) Efficiency vs. Output Current

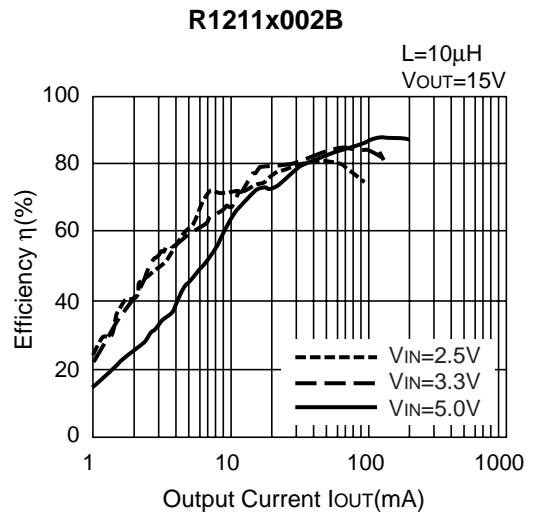
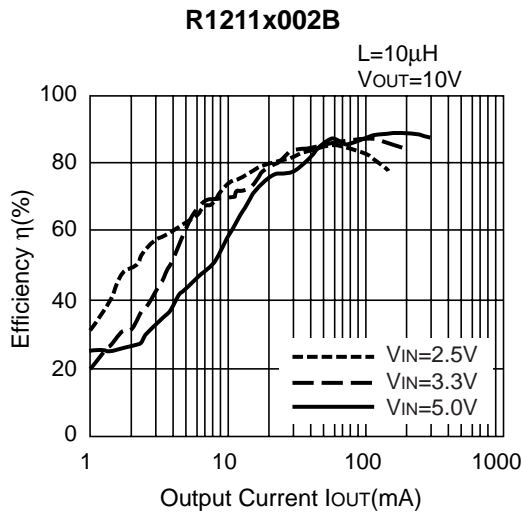
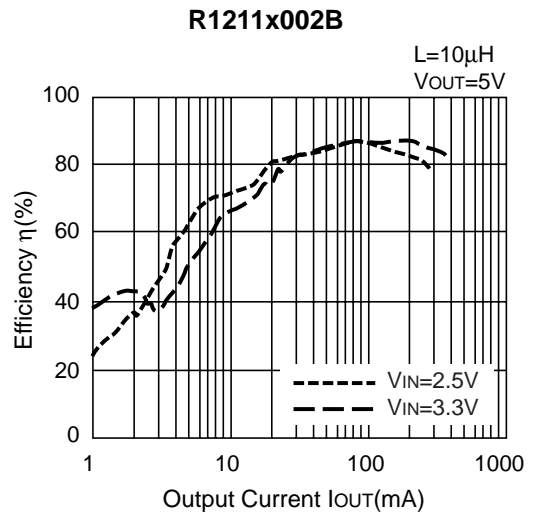
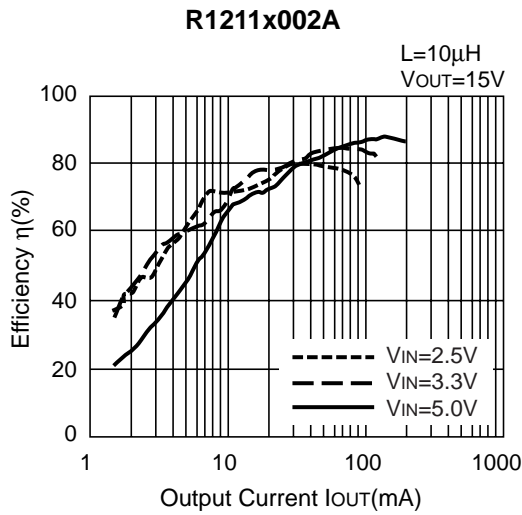
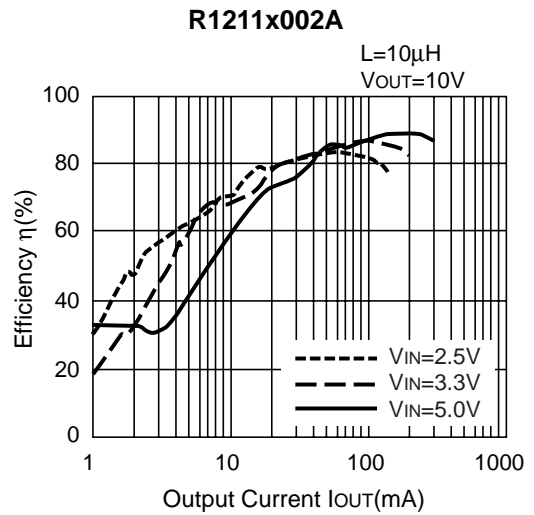
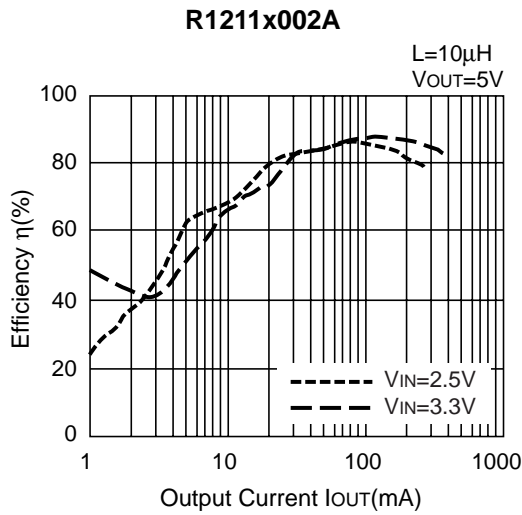

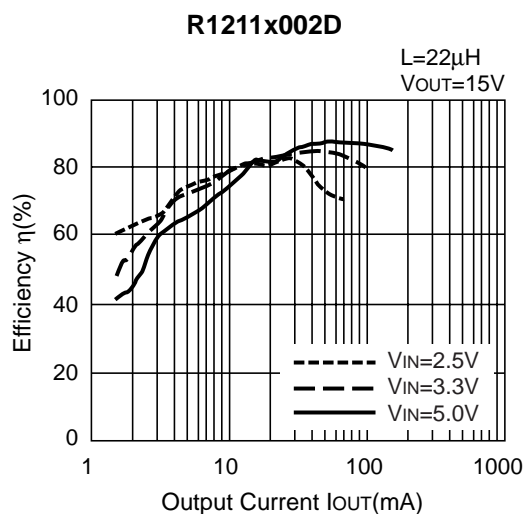
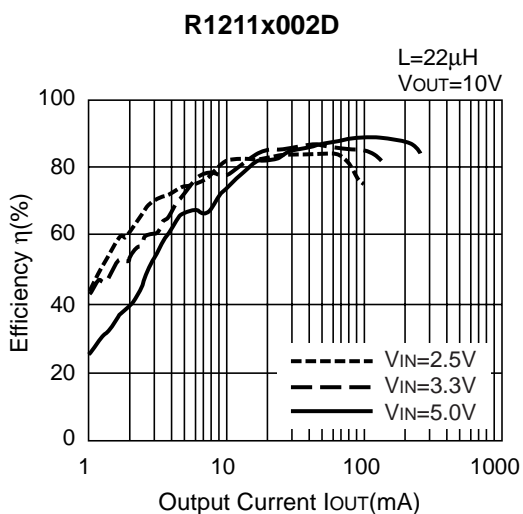
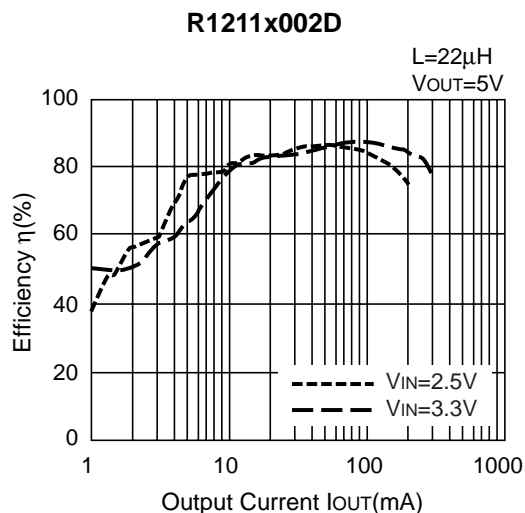
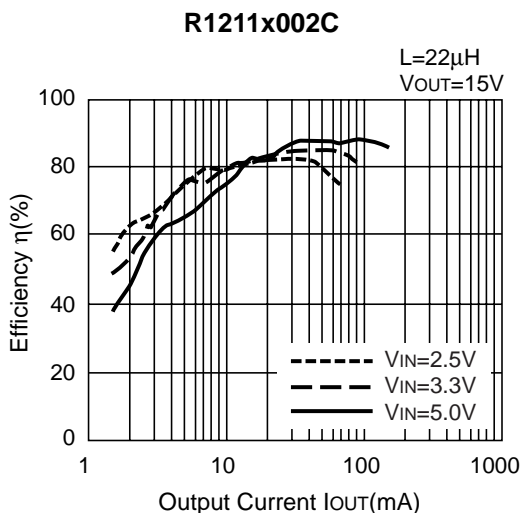
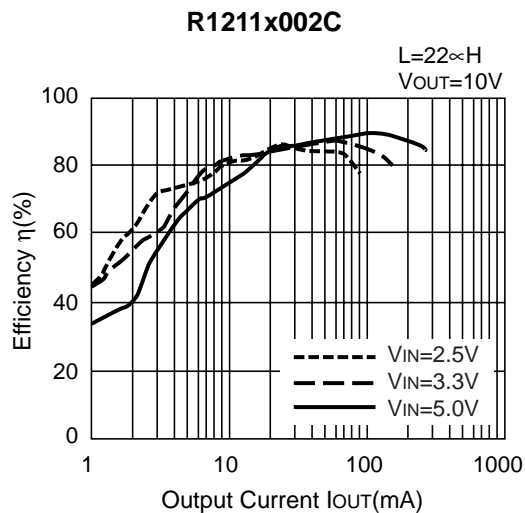
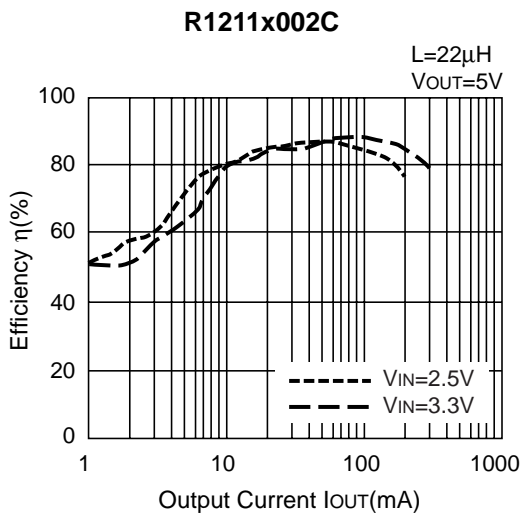

3)  $V_{FB}$  Voltage vs. Input Voltage (Topt=25°C)

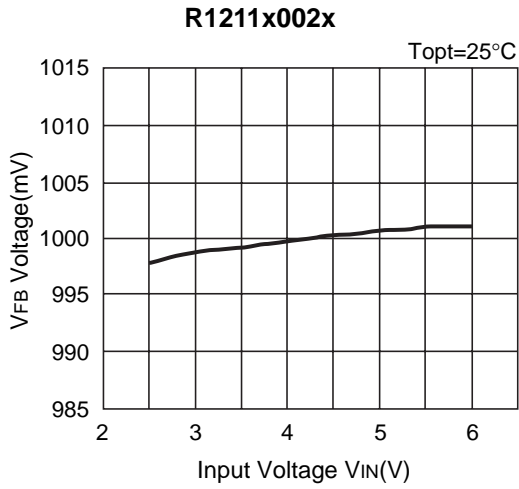

4) Oscillator Frequency vs. Input Voltage (Topt=25°C)

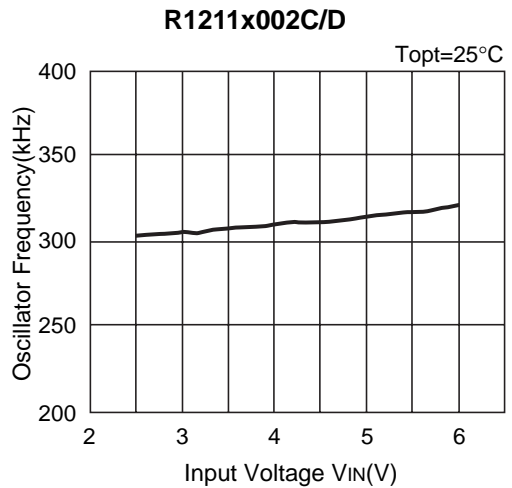
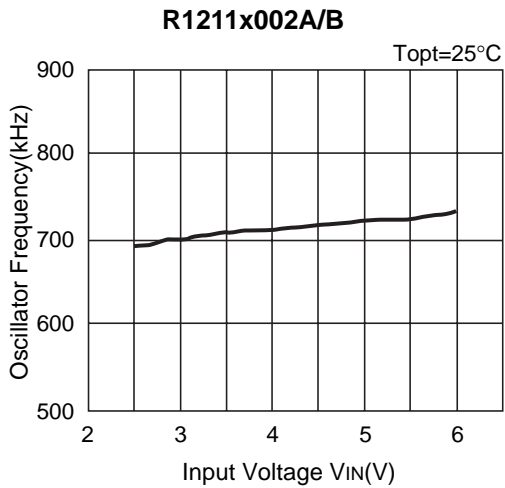

5) Supply Current vs. Input Voltage (Topt=25°C)

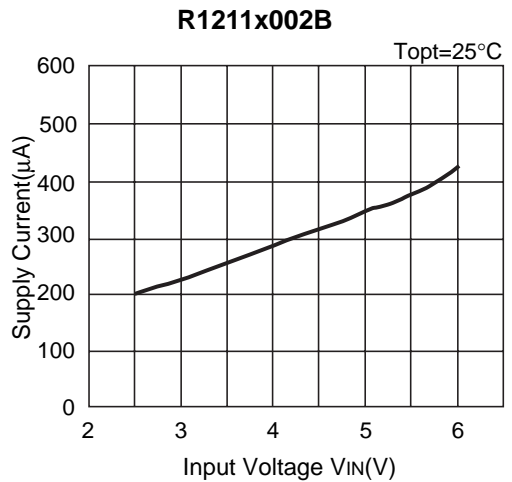
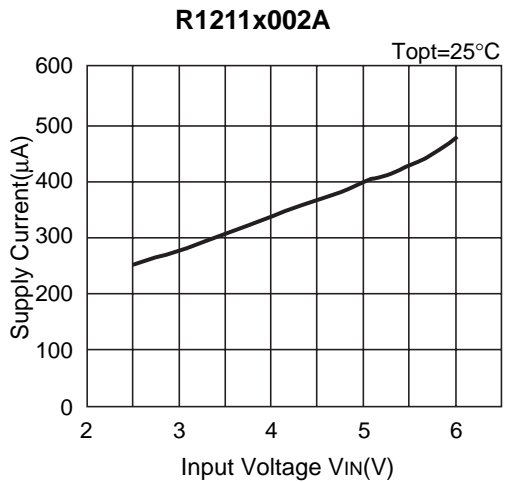

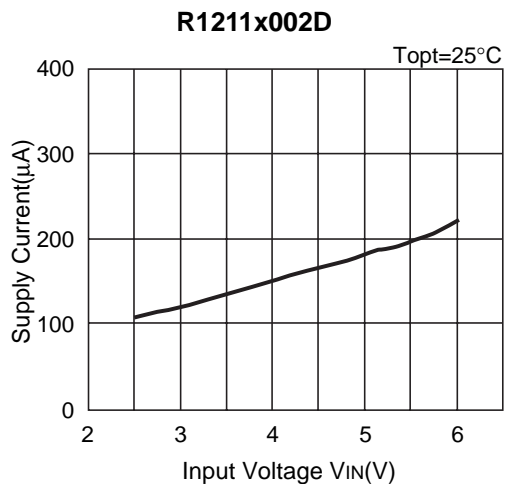
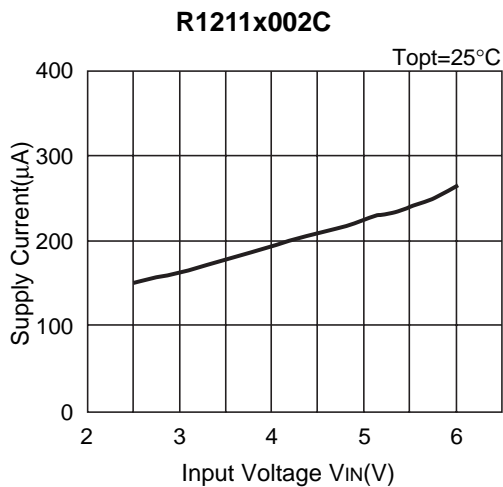

**6) Maximum Duty Cycle vs. Input Voltage (Topt=25°C)**

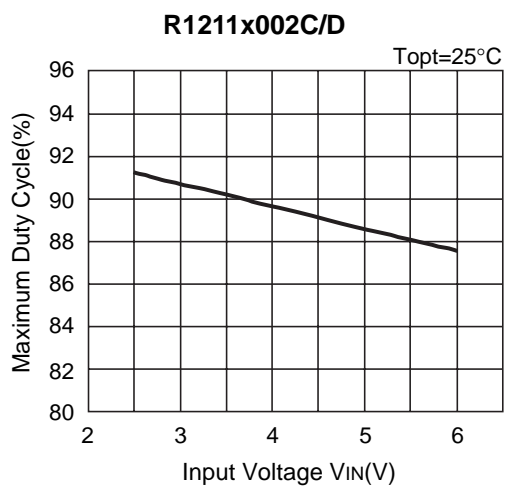
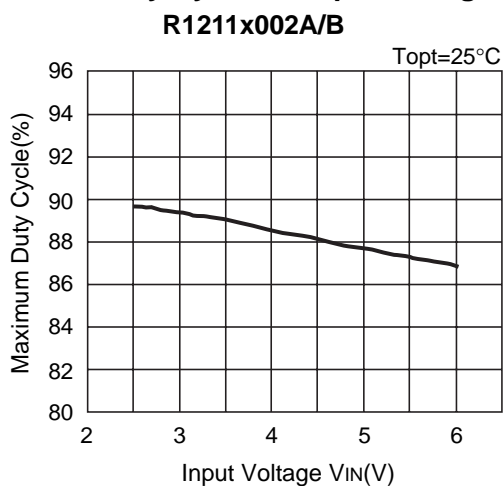

**7) VFB Voltage vs. Temperature**

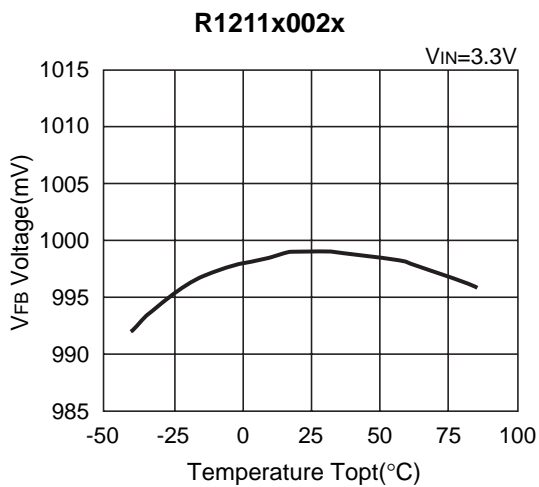

8) Oscillator Frequency vs. Temperature

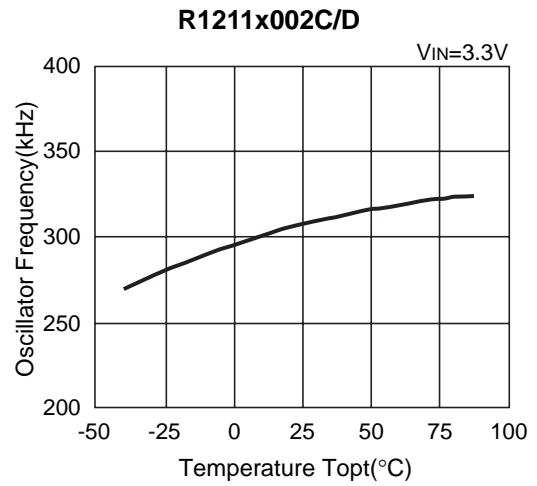
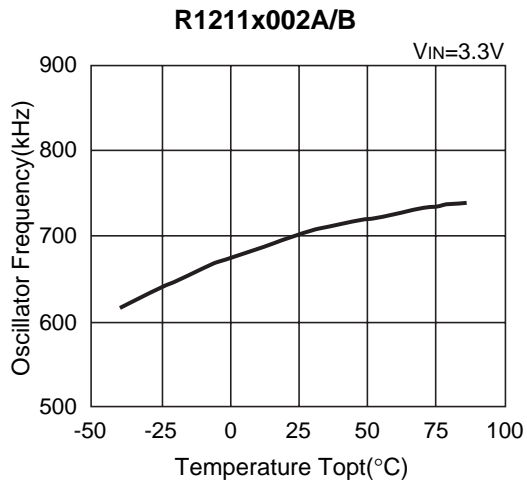

9) Supply Current vs. Temperature

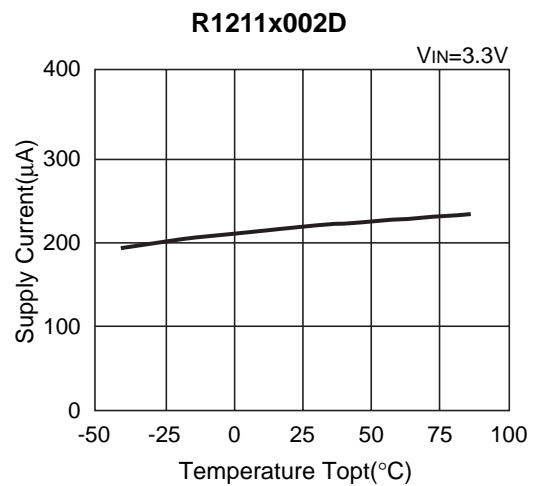
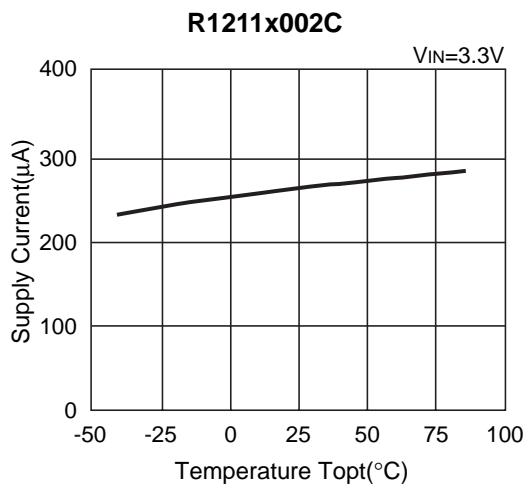
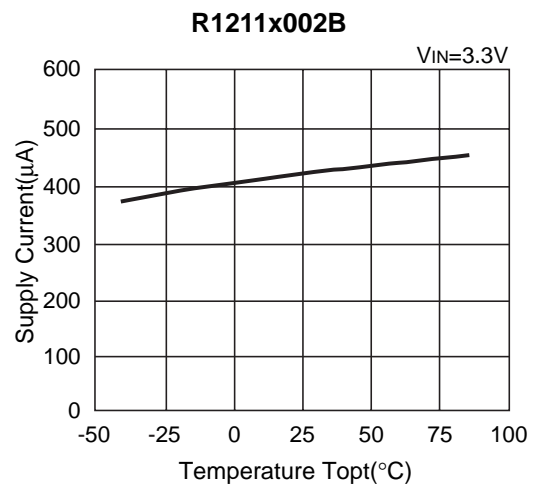
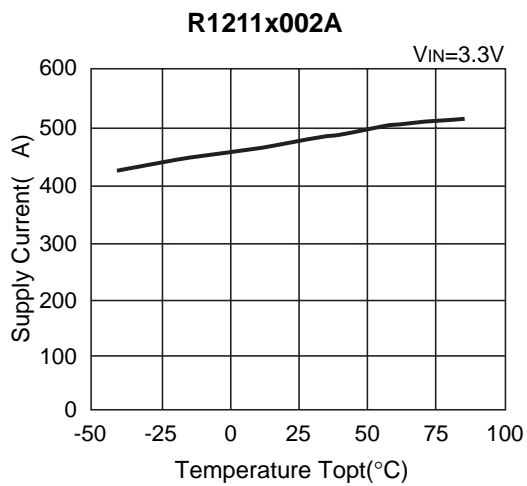



10) Maximum Duty Cycle vs. Temperature

R1211x002A/B

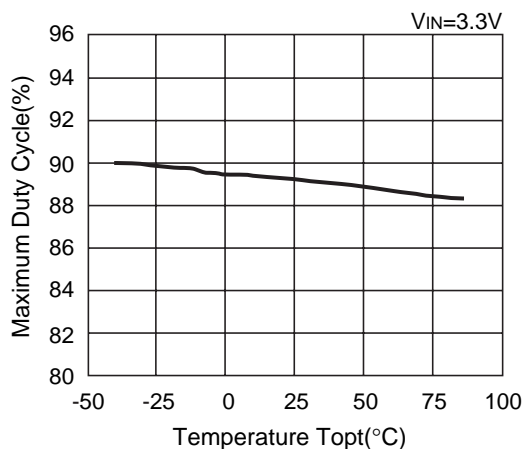

R1211x002C/D

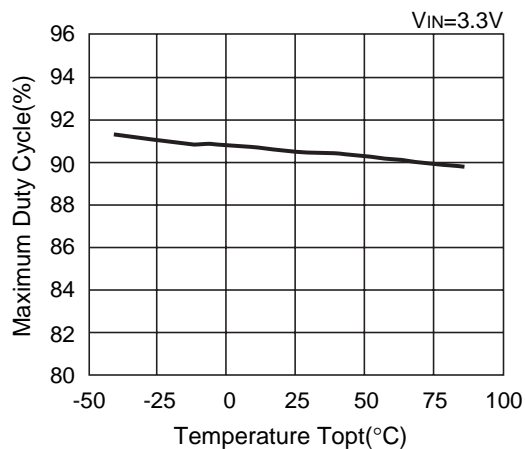

11) EXT "H" On Resistance vs. Temperature

R1211x002x

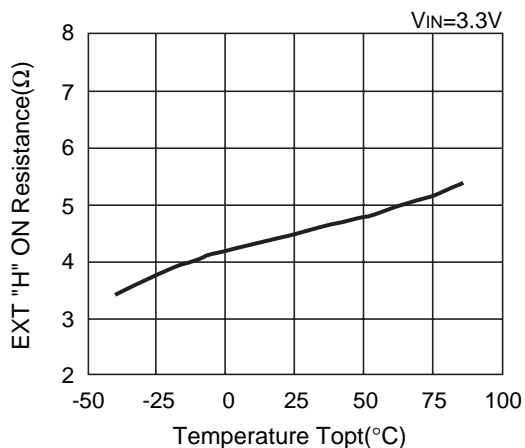

12) EXT "L" On Resistance vs. Temperature

R1211x002x

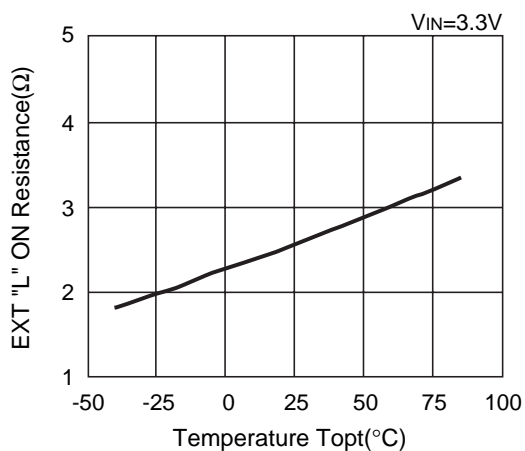

13) Soft-start Time vs. Temperature

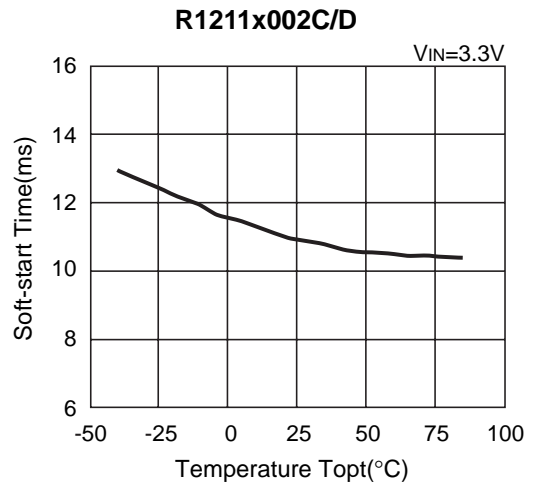
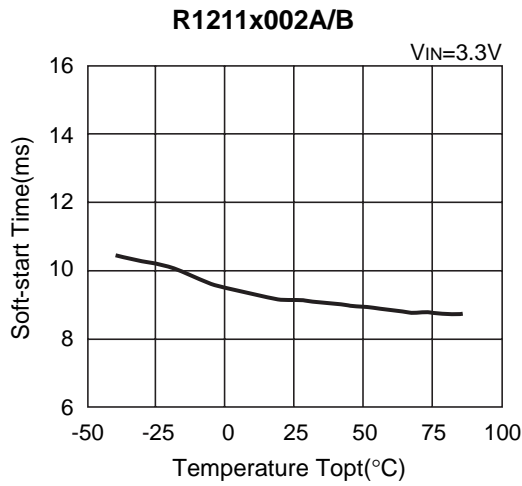

14) UVLO Detector Threshold vs. Temperature

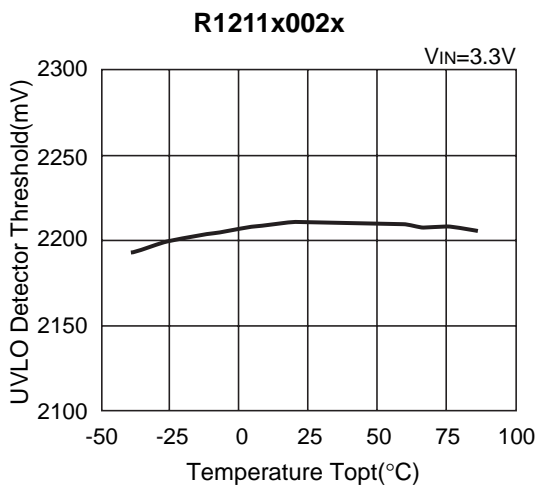

15) AMP "H" Output Current vs. Temperature

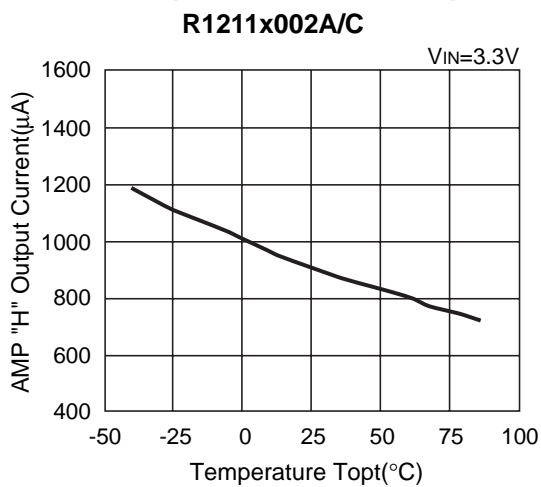

16) AMP "L" Output Current vs. Temperature

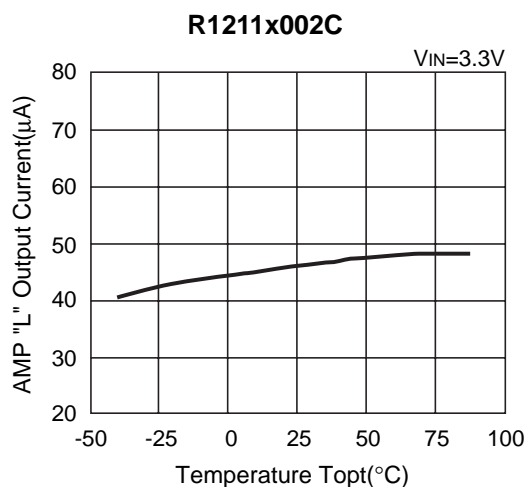
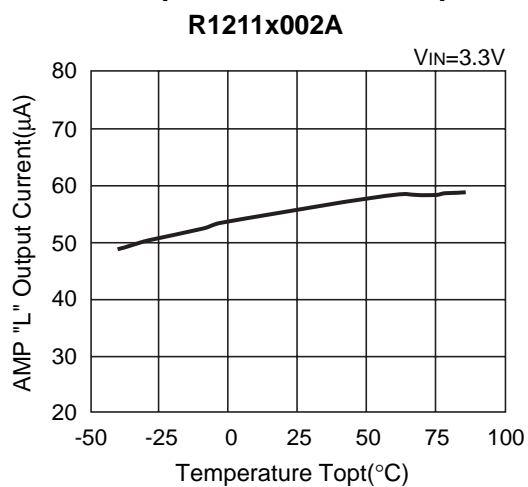

17) DELAY Pin Charge Current vs. Temperature

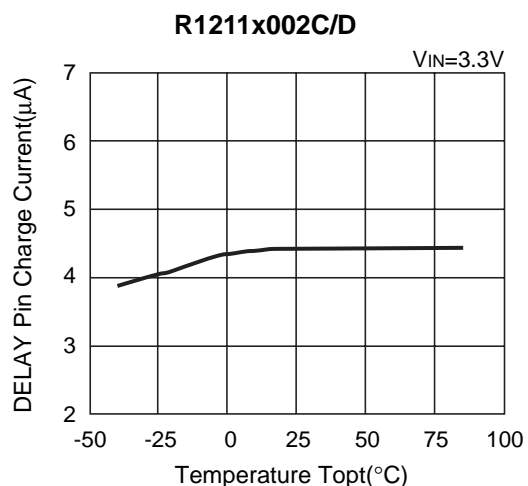
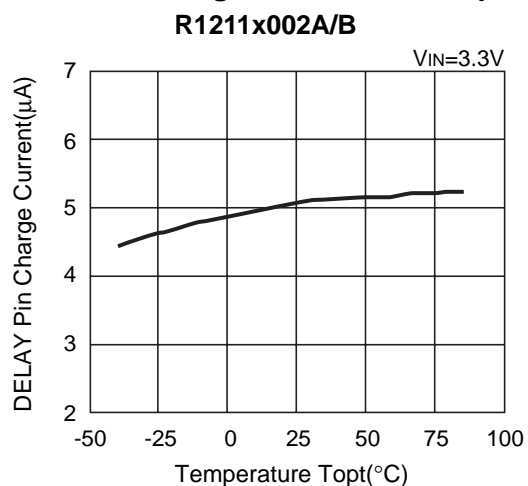

18) DELAY Pin Detector Threshold vs. Temperature

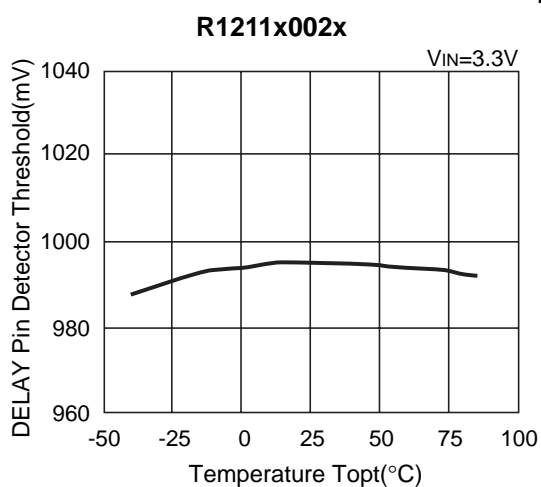

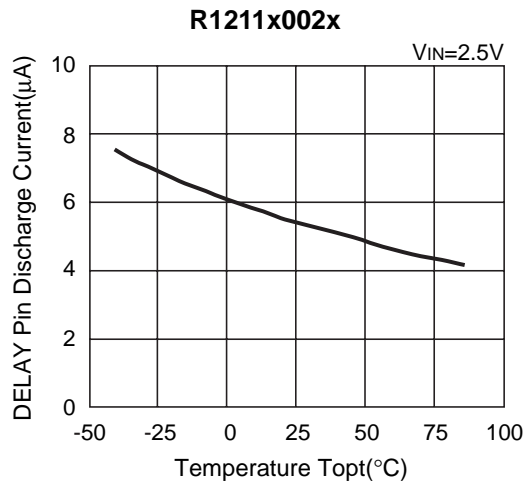
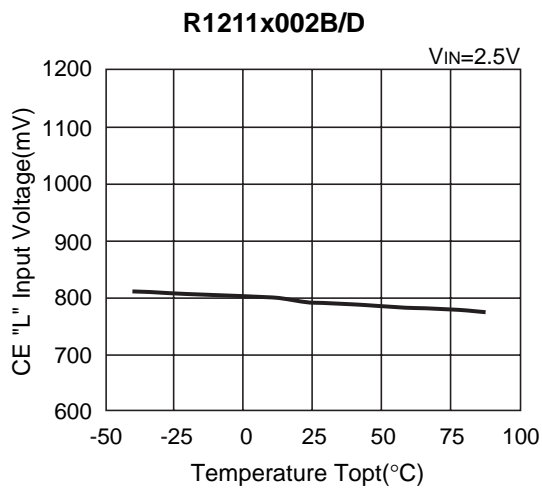
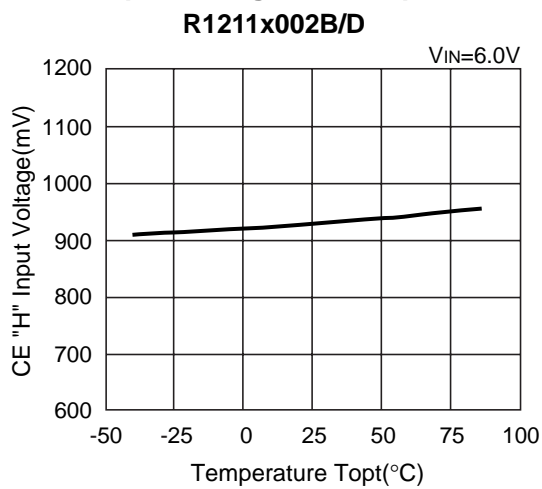
**19) DELAY Pin Discharge Current vs. Temperature****20) CE "L" Input Voltage vs. Temperature****21) CE "H" Input Voltage vs. Temperature**

22) Standby Current vs. Temperature

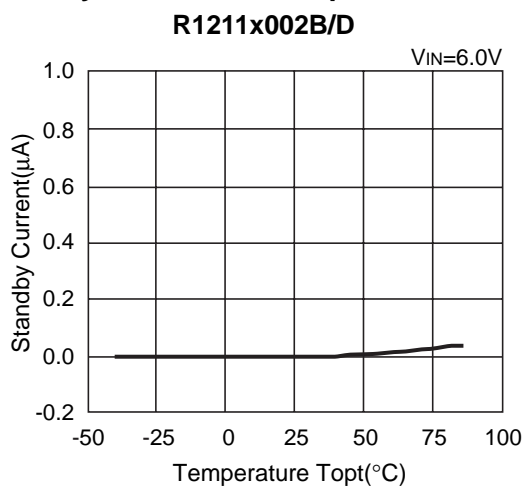

23) Load Transient Response

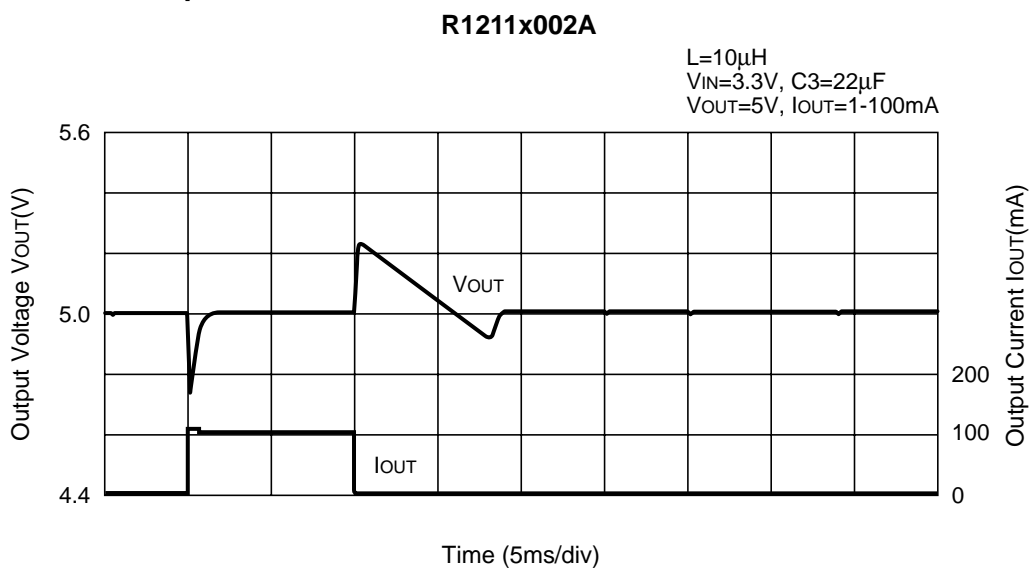

R1211x002A

R1211x002A

L=10 $\mu$ H  
VIN=3.3V, C3=22 $\mu$ F  
VOUT=15V, IOUT=1-50mA

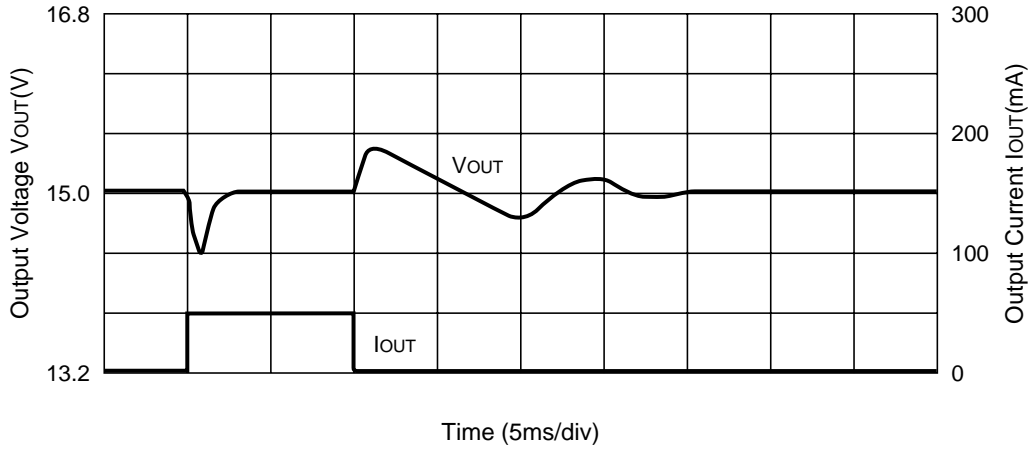

R1211x002B

L=10 $\mu$ H  
VIN=3.3V, C3=22 $\mu$ F  
VOUT=5V, IOUT=1-100mA

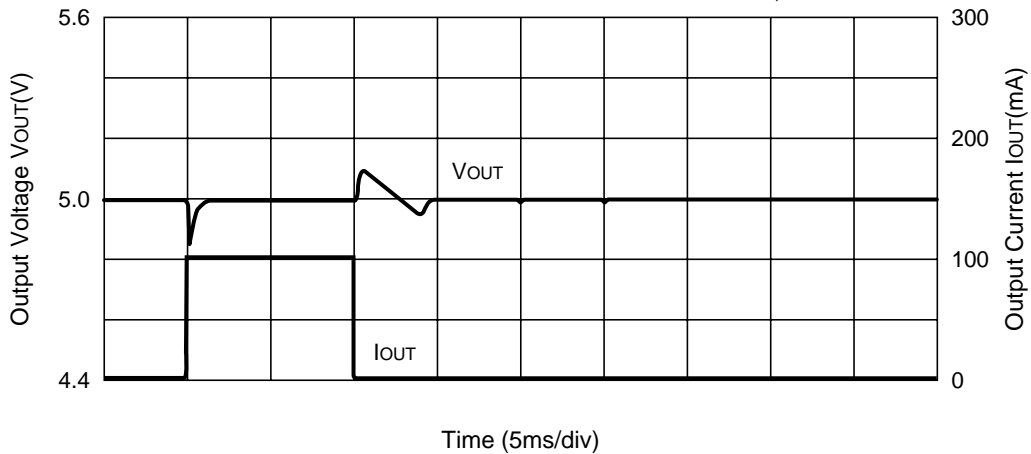

R1211x002B

L=10 $\mu$ H  
VIN=3.3V, C3=22 $\mu$ F  
VOUT=10V, IOUT=1-100mA

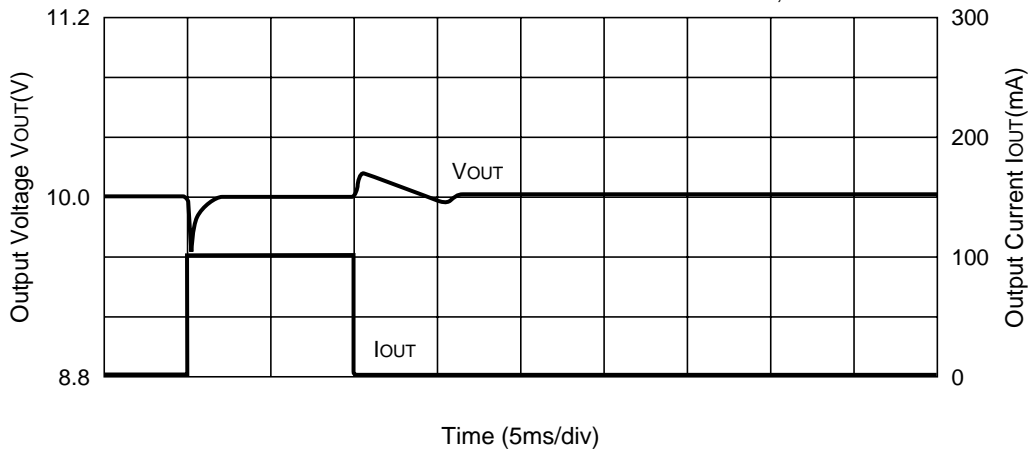

R1211x002B

L=10 $\mu$ H  
 VIN=3.3V, C3=22 $\mu$ F  
 VOUT=15V, IOUT=1-50mA

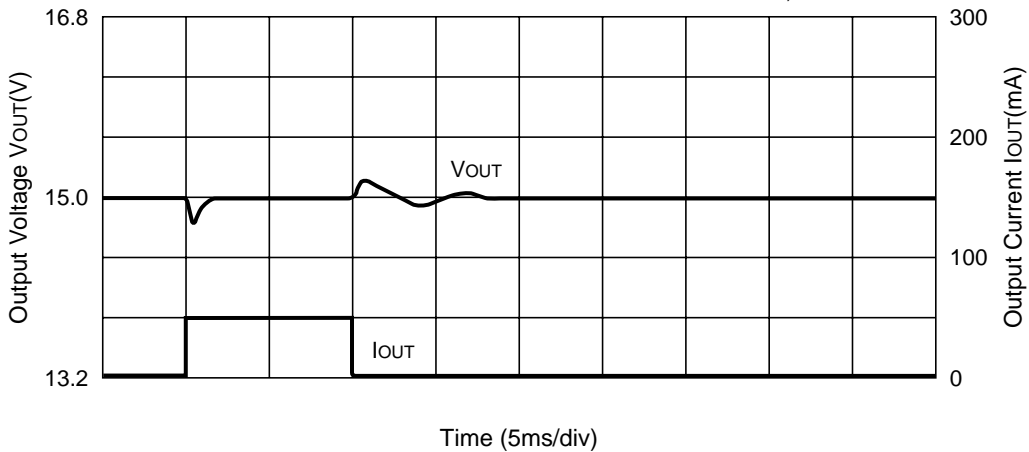

R1211x002C

L=22 $\mu$ H  
 VIN=3.3V, C3=22 $\mu$ F  
 VOUT=5V, IOUT=1-100mA

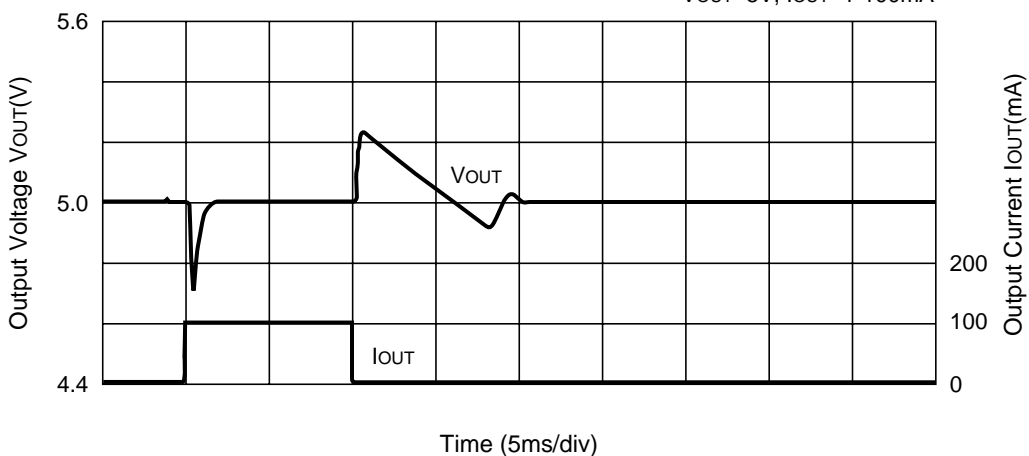

R1211x002C

L=22 $\mu$ H  
 VIN=3.3V, C3=22 $\mu$ F  
 VOUT=10V, IOUT=1-100mA

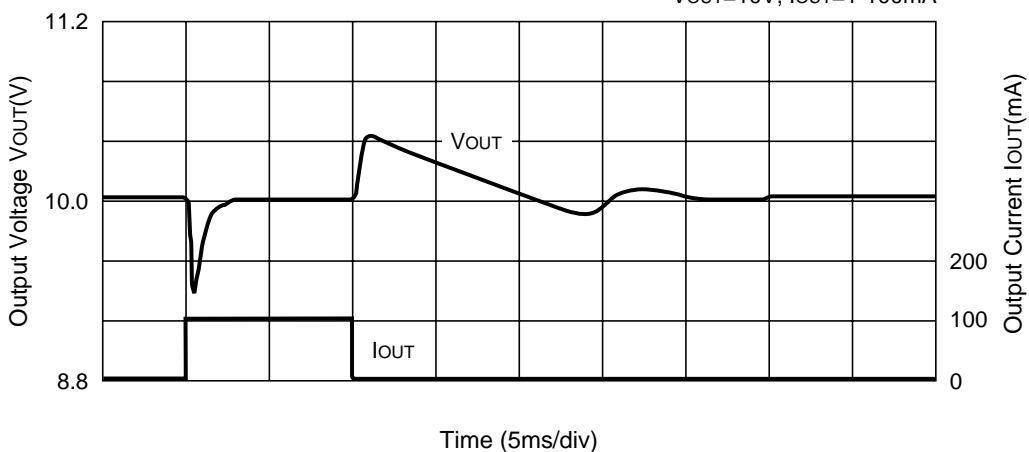

R1211x002C

L=22 $\mu$ H  
VIN=3.3V, C3=22 $\mu$ F  
VOUT=15V, IOUT=1-50mA

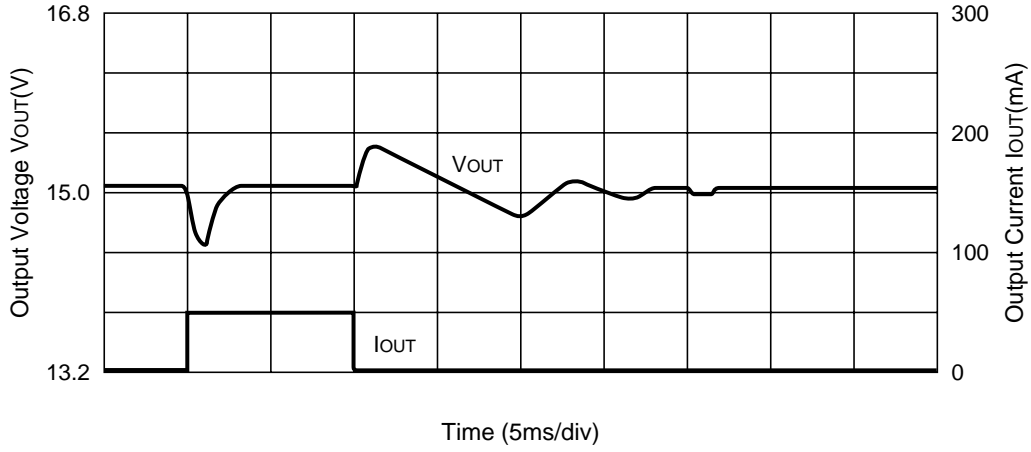

R1211x002D

L=22 $\mu$ H  
VIN=3.3V, C3=22 $\mu$ F  
VOUT=5V, IOUT=1-100mA

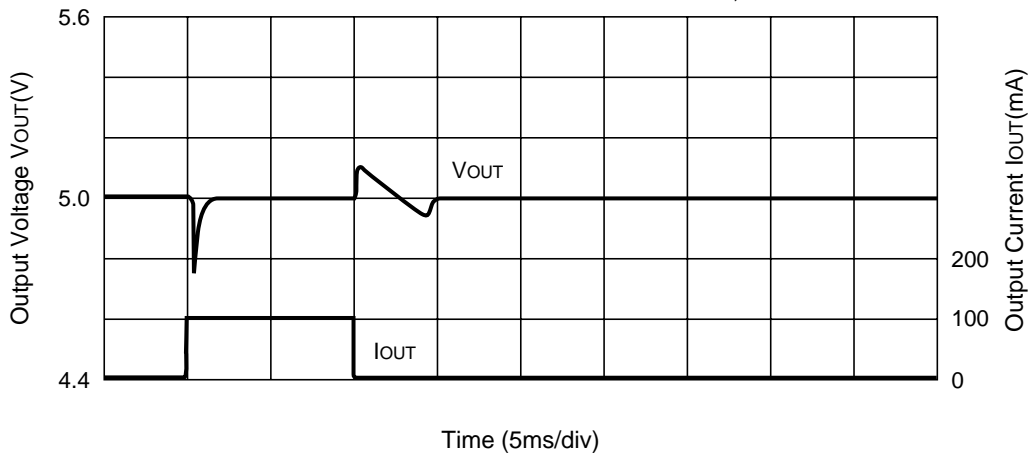

R1211x002D

L=22 $\mu$ H  
VIN=3.3V, C3=22 $\mu$ F  
VOUT=10V, IOUT=1-100mA

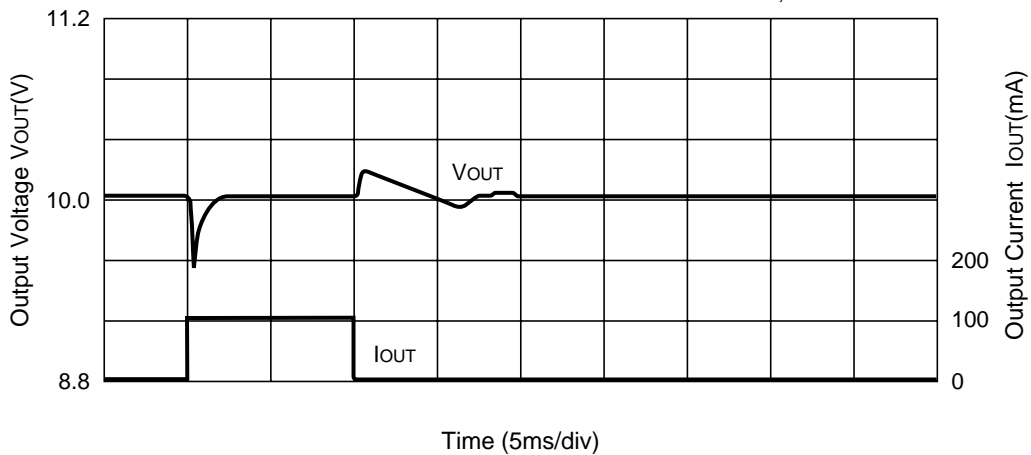



R1211x002D

L=22 $\mu$ H  
 V<sub>IN</sub>=3.3V, C<sub>3</sub>=22 $\mu$ F  
 V<sub>OUT</sub>=15V, I<sub>OUT</sub>=1-50mA

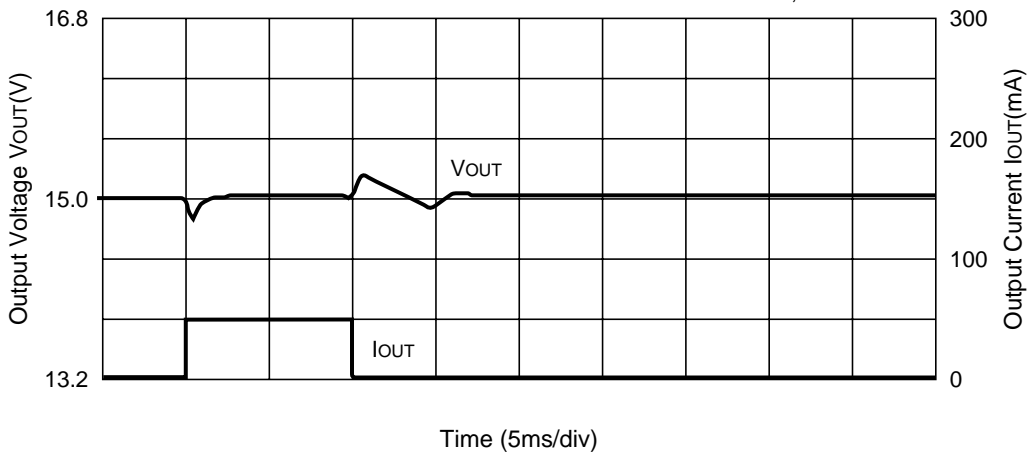

24) Power-on Response

R1211x002A

L=10 $\mu$ H  
 V<sub>IN</sub>=3.3V, I<sub>OUT</sub>=10mA

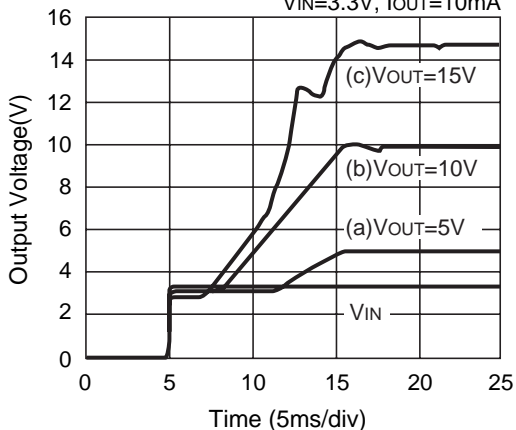

R1211x002B

L=10 $\mu$ H  
 V<sub>IN</sub>=3.3V, I<sub>OUT</sub>=10mA

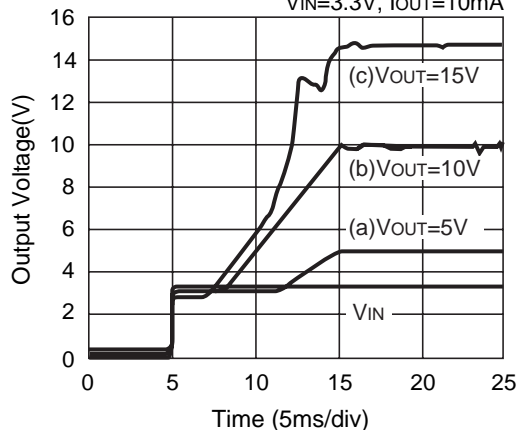

R1211x002C

L=22 $\mu$ H  
 V<sub>IN</sub>=3.3V, I<sub>OUT</sub>=10mA

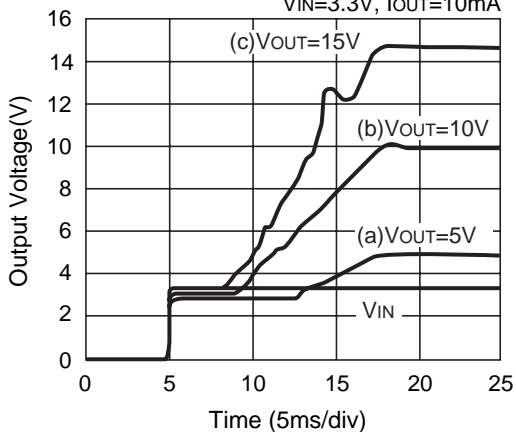

R1211x002D

L=22 $\mu$ H  
 V<sub>IN</sub>=3.3V, I<sub>OUT</sub>=10mA

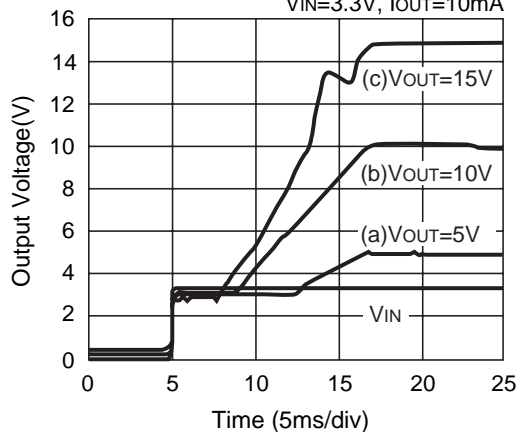

25) Turn-on speed with CE pin

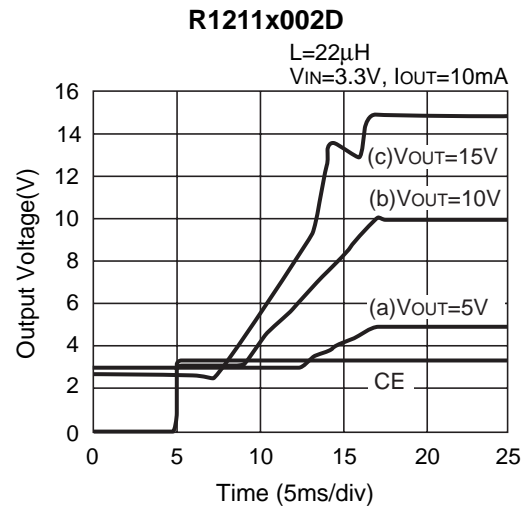
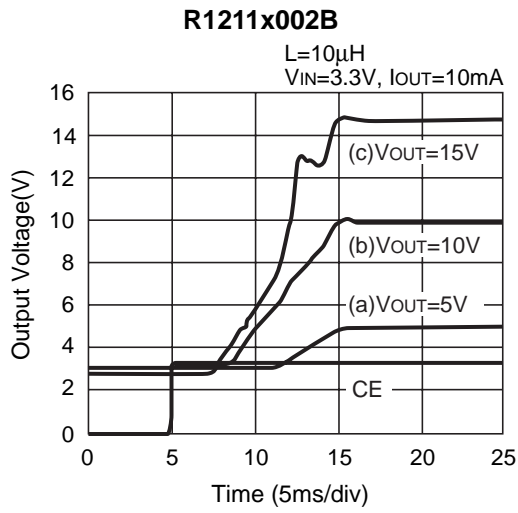

• SOT-23-6W

Unit: mm

PACKAGE DIMENSIONS

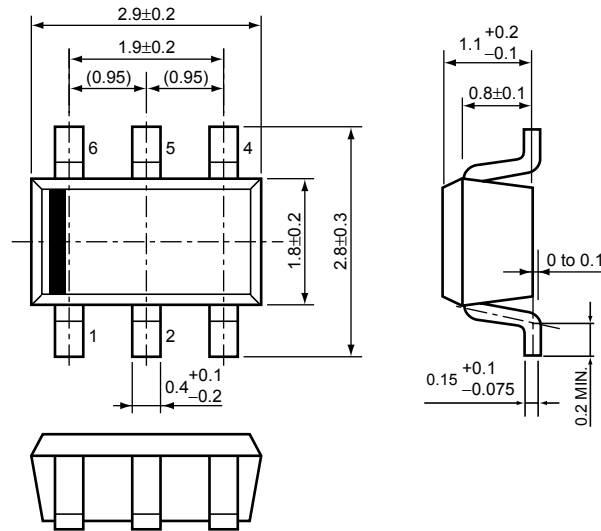

TAPING SPECIFICATION

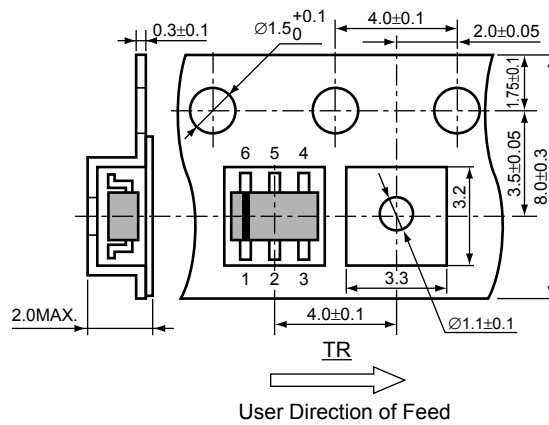

TAPING REEL DIMENSIONS

(1reel=3000pcs)

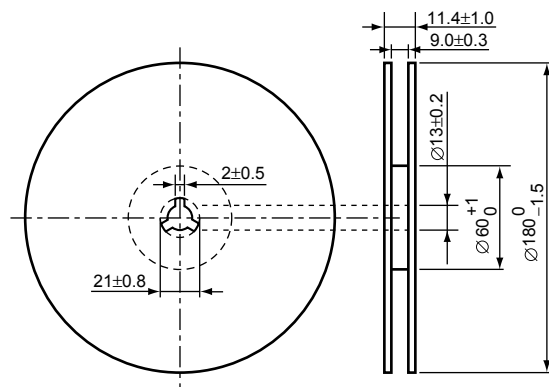

### POWER DISSIPATION (SOT-23-6W)

This specification is at mounted on board. Power Dissipation ( $P_D$ ) depends on conditions of mounting on board. This specification is based on the measurement at the condition below:

Measurement Conditions

	Standard Land Pattern
Environment	Mounting on Board (Wind velocity=0m/s)
Board Material	Glass cloth epoxy plactic (Double sided)
Board Dimensions	40mm × 40mm × 1.6mm
Copper Ratio	Top side : Approx. 50% , Back side : Approx. 50%
Through-hole	φ0.5mm × 44pcs

Measurement Result

( $T_{opt}=25^{\circ}C, T_{jmax}=125^{\circ}C$ )

	Standard Land Pattern
Power Dissipation	430mW
Thermal Resistance	$\theta_{ja}=(125-25^{\circ}C)/0.43W=233^{\circ}C/W$

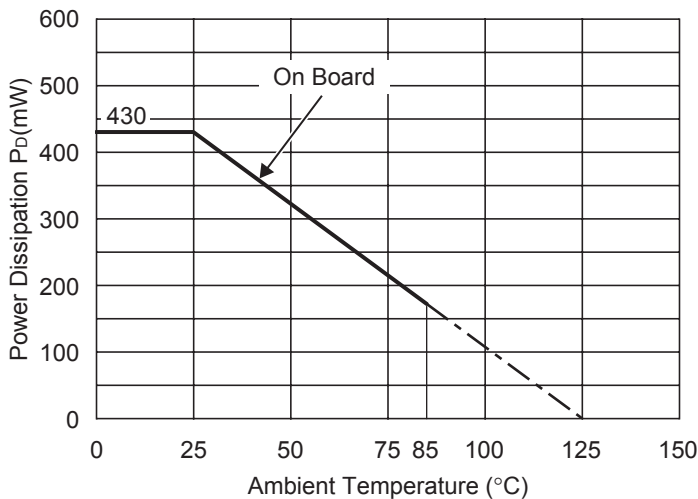

Power Dissipation

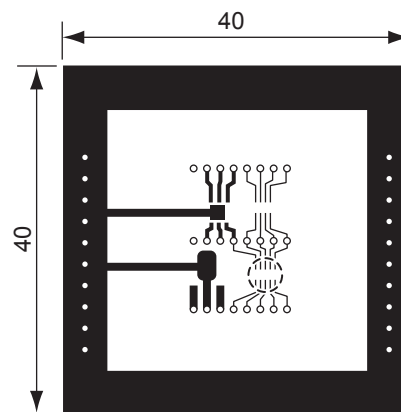

Measurement Board Pattern

○ IC Mount Area Unit : mm

### RECOMMENDED LAND PATTERN (SOT-23-6W)

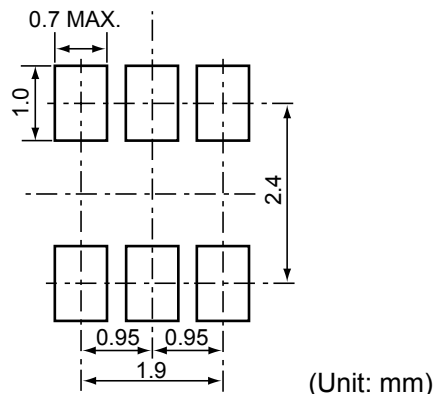

• SON-6

Unit: mm

PACKAGE DIMENSIONS

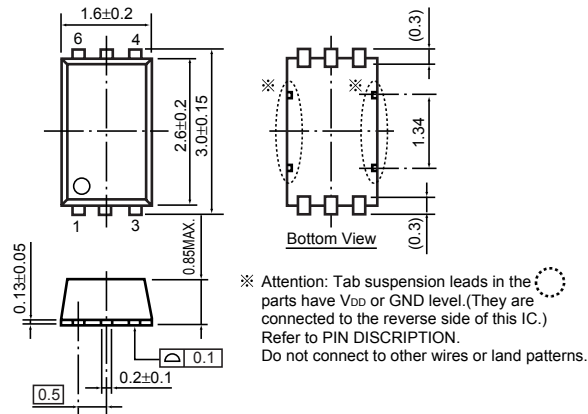

TAPING SPECIFICATION

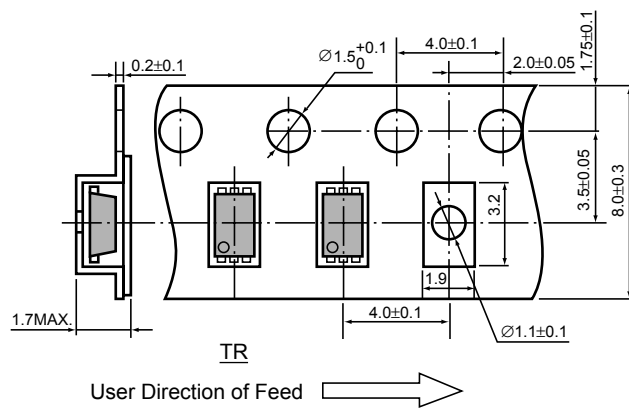

TAPING REEL DIMENSIONS

(1reel=3000pcs)

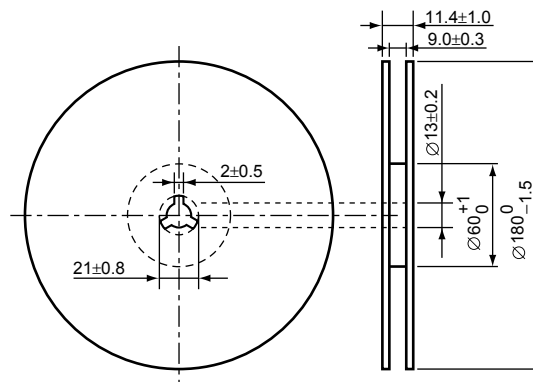

## POWER DISSIPATION (SON-6)

This specification is at mounted on board. Power Dissipation ( $P_D$ ) depends on conditions of mounting on board. This specification is based on the measurement at the condition below:

### Measurement Conditions

	Standard Land Pattern
Environment	Mounting on Board (Wind velocity=0m/s)
Board Material	Glass cloth epoxy plactic (Double sided)
Board Dimensions	40mm × 40mm × 1.6mm
Copper Ratio	Top side : Approx. 50% , Back side : Approx. 50%
Through-hole	φ0.5mm × 44pcs

### Measurement Result

( $T_{opt}=25^{\circ}C, T_{jmax}=125^{\circ}C$ )

	Standard Land Pattern	Free Air
Power Dissipation	500mW	250mW
Thermal Resistance	$\theta_{ja}=(125-25^{\circ}C)/0.5W=200^{\circ}C/W$	-

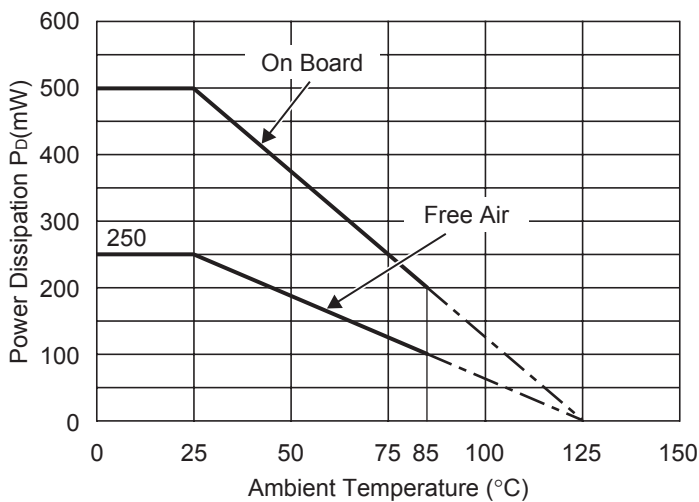

Power Dissipation

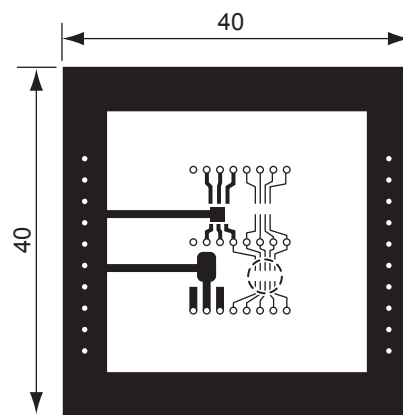

Measurement Board Pattern

○ IC Mount Area (Unit : mm)

## RECOMMENDED LAND PATTERN

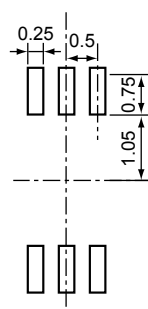

(Unit: mm)

## R1211N SERIES MARK SPECIFICATION

- SOT-23-6W

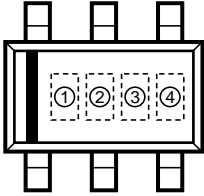

①, ② : Product Code (refer to Part Number vs. Product Code)

③, ④ : Lot Number

- Part Number vs. Product Code

Part Number	Product Code	
	①	②
R1211N002A	L	0
R1211N002B	L	1
R1211N002C	L	2
R1211N002D	L	3

**R1211D SERIES MARK SPECIFICATION**

• SON-6

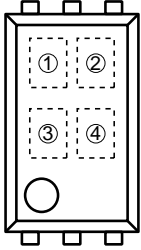

①, ② : Product Code (refer to Part Number vs. Product Code)

③, ④ : Lot Number

• Part Number vs. Product Code

Part Number	Product Code	
	①	②
R1211D002A	L	0
R1211D002B	L	1
R1211D002C	L	2
R1211D002D	L	3
R1211D100A	L	4
R1211D101A	L	5

Part Number	Product Code	
	①	②
R1211D102A	L	6
R1211D101C	L	7
R1211D102C	L	8
R1211D103A	L	9
R1211D103C	L	A
R1211D104A	L	B



Компания «Life Electronics» занимается поставками электронных компонентов импортного и отечественного производства от производителей и со складов крупных дистрибьюторов Европы, Америки и Азии.

С конца 2013 года компания активно расширяет линейку поставок компонентов по направлению коаксиальный кабель, кварцевые генераторы и конденсаторы (керамические, пленочные, электролитические), за счёт заключения дистрибьюторских договоров

Мы предлагаем:

- Конкурентоспособные цены и скидки постоянным клиентам.
- Специальные условия для постоянных клиентов.
- Подбор аналогов.
- Поставку компонентов в любых объемах, удовлетворяющих вашим потребностям.
- Приемлемые сроки поставки, возможна ускоренная поставка.
- Доставку товара в любую точку России и стран СНГ.
- Комплексную поставку.
- Работу по проектам и поставку образцов.
- Формирование склада под заказчика.
- Сертификаты соответствия на поставляемую продукцию (по желанию клиента).
- Тестирование поставляемой продукции.
- Поставку компонентов, требующих военную и космическую приемку.
- Входной контроль качества.
- Наличие сертификата ISO.

В составе нашей компании организован Конструкторский отдел, призванный помогать разработчикам, и инженерам.

Конструкторский отдел помогает осуществить:

- Регистрацию проекта у производителя компонентов.
- Техническую поддержку проекта.
- Защиту от снятия компонента с производства.
- Оценку стоимости проекта по компонентам.
- Изготовление тестовой платы монтаж и пусконаладочные работы.



Тел: +7 (812) 336 43 04 (многоканальный)

Email: [org@lifeelectronics.ru](mailto:org@lifeelectronics.ru)