



Features

- 3.3 and 5 VDC voltage supply option
- Quadrature output
- Bushing or servo mount
- Non-contacting magnetic technology
- Small size
- CMOS and TTL compatible
- Resolution from 32-256 PPR
- Long life
- High operating speed
- Highly repeatable
- Sealed option
- Magnetic technology

EMS22Q - Non-Contacting Incremental Encoder

Electrical Characteristics

Resolution	32 to 256 PPR
Insulation Resistance (500 VDC)	1,000 megohms
Electrical Travel	Continuous
Supply Voltage	5.0 VDC $\pm 10\%$, 3.3 VDC $\pm 10\%$
Supply Current	20 mA maximum
Output Voltage	
Low Output Level	V _{ss} +0.4 V maximum
High Output Level	V _{dd} -0.5 V minimum
Output Current	
With 4.5 VDC Supply Voltage	4 mA maximum
With 3.0 VDC Supply Voltage	2 mA maximum
Rise/Fall Time (Incremental Output)	500 ns maximum
Shaft RPM (Ball Bearing)	10,000 rpm maximum
Hysteresis	0.7 °
Accuracy	
Nominal	$\pm 0.7^\circ$ or better
Worst Case	$\pm 1.4^\circ$
Output Transition Noise	0.12 ° RMS max.

Environmental Characteristics

Operating Temperature Range	-40 °C to +125 °C (-40 °F to +257 °F)
Storage Temperature Range	-55 °C to +125 °C (-67 °F to +257 °F)
Humidity	MIL-STD-202, Method 103B, Condition B
Vibration	15 G
Shock	50 G
Rotational Life	
S Bushing (@1,000 rpm)	100,000,000 revolutions
T & W Bushings (@1,000 rpm with 250 g side load)	50,000,000 revolutions
IP Rating	IP 65

Mechanical Characteristics

Mechanical Angle	360 ° Continuous
Torque	
Starting	43 ± 21 g-cm (0.6 ± 0.3 oz-in.)
Running	29 ± 14 g-cm (0.4 ± 0.2 oz-in.)
Mounting Torque	203 N-cm (18 lb.-in.)
Shaft End Play	0.30 mm (0.012 ") T.I.R. maximum
Shaft Radial Play	0.12 mm (0.005 ") T.I.R. maximum
Weight	11 gms. (0.4 oz.)
Terminals	Axial, radial or ribbon cable
Soldering Condition	
Manual Soldering	96.5Sn/3.0Ag/0.5Cu solid wire or no-clean rosin cored wire 370 °C (700 °F) max. for 3 seconds
Wave Soldering	96.5Sn/3.0Ag/0.5Cu solder with no-clean flux 260 °C (500 °F) max. for 10 seconds
Wash processes	Not recommended
Marking	Manufacturer's trademark, name, part number, and date code.
Hardware	One lockwasher and one mounting nut supplied with each encoder, except on servo mount versions.

Pin Configuration

Output Type	Pin 1	Pin 2	Pin 3	Pin 4	Pin 5	Pin 6
A/B Quadrature	A	B	GND	Index	VCC*	CS**

* Can be 5 or 3.3 VDC depending on the version.

** Active low chip select pin; if not used connect pin 6 to GND.

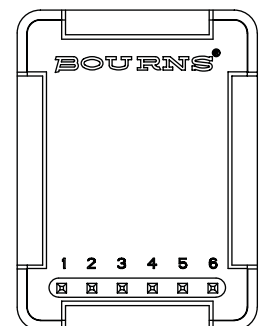

Applications

- Material handling equipment
- Brushless DC motor commutation
- Robotics
- Automotive
- Industrial automation
- Petroleum refinery
- Medical
- Office equipment
- Audio and broadcast equipment

EMS22Q - Non-Contacting Incremental Encoder

BOURNS®

Output Type Waveform and Variant Table

Quadrature Output

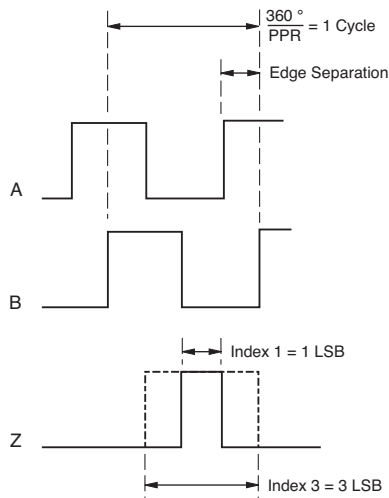

PPR	3.3 Vcc	5.0 Vcc	Index 1	Index 3
256	X		X	
256	X			X
256		X	X	
256		X		X
128	X		X	
128	X			X
128		X	X	
128		X		X
64	X		X	
64	X			X
64		X	X	
64		X		X
32	X		X	
32	X			X
32		X	X	
32		X		X

Minimum edge separation = $20 \times 256 / \text{PPR}$ (no missing pulses)

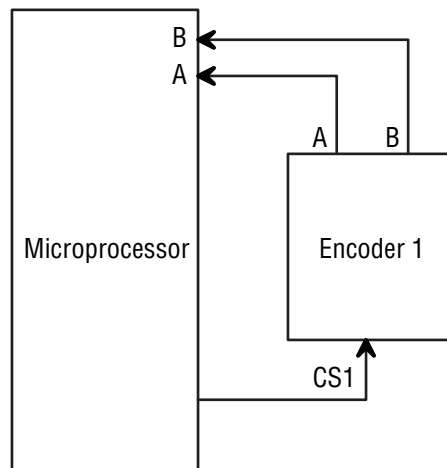

Chip Select Hardware Sample

Consult factory for options not shown, including:

- Wire lead or cable options
- Connectors
- Non-standard resolutions
- Special shaft/bushing sizes and features
- Special performance characteristics
- PCB mounting bracket

EMS22Q - Non-Contacting Incremental Encoder

BOURNS®

Dimensional Drawings

Shaft Style D (Bushing T)

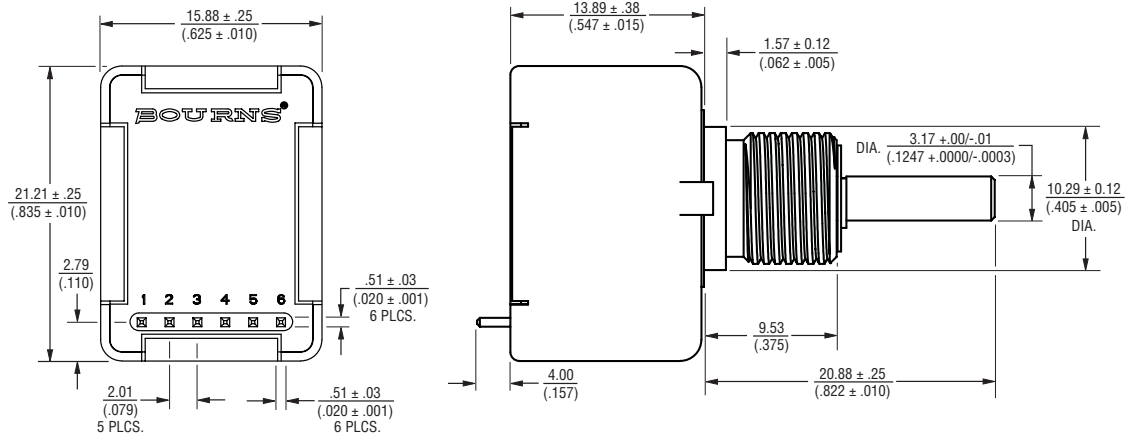

Shaft Style B (Bushing S)

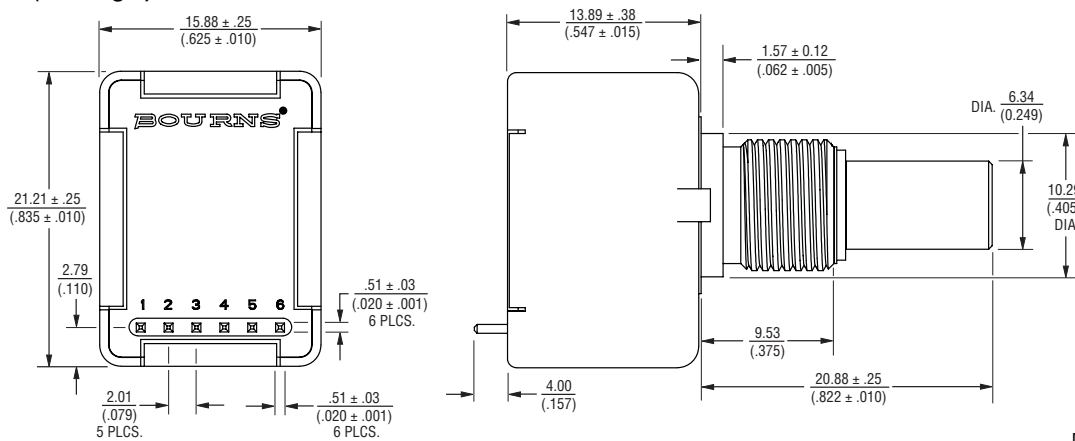

Shaft Style D (Bushing W)

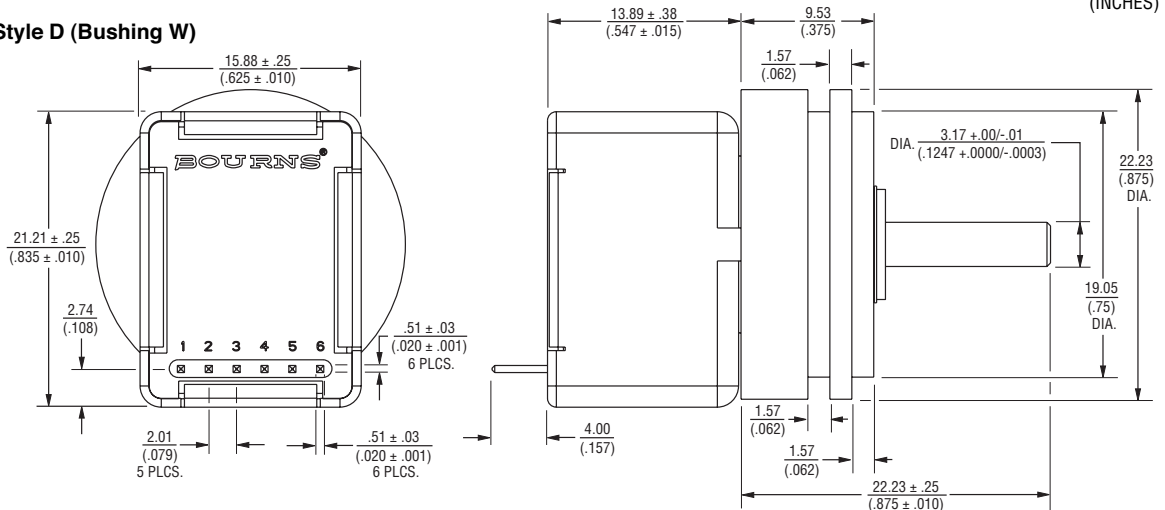

DIMENSIONS: $\frac{\text{MM}}{\text{(INCHES)}}$

Specifications are subject to change without notice.
 Customers should verify actual device performance in their specific applications.

EMS22Q - Non-Contacting Incremental Encoder

BOURNS®

Product Dimensions

Cable Assembly

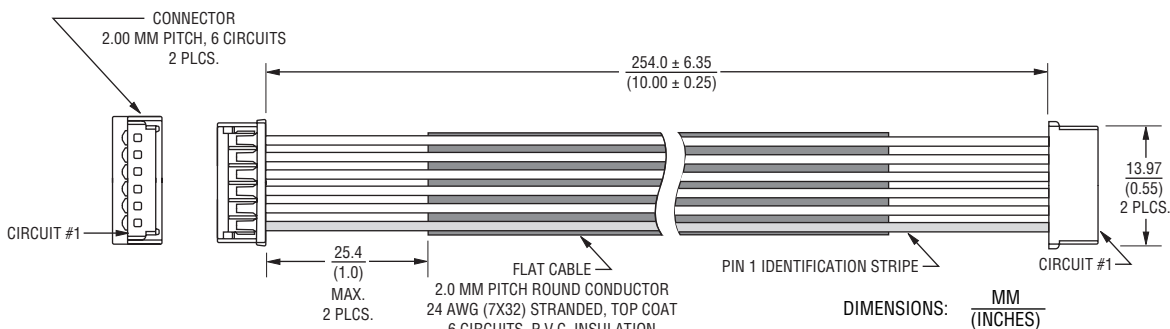

How To Order

BOURNS EMS22 22 MM NON-CONTACTING INCREMENTAL ENCODER

E M S 2 2 Q 5 1 - B 2 8 - L S 4

INDEX CHANNEL	
Code	Description
1	1 LSB
3	3 LSB

VOLTAGE SUPPLY	
Code	Description
3	3.3 VDC
5	5 VDC

SHAFT STYLE		
Code	Description	Available With Bushings (Code)
B	1/4 " Dia., Plain End	S
C	1/4 " Dia., Flatted End	S
D	1/8 " Dia., Plain End	T, W
R	6 mm Dia., Slotted End	D
M	6 mm Dia., Flatted End	D

SHAFT LENGTH DESIGNATOR*	
Code	Description
16	1/2 " Long
20	5/8 " Long
28	7/8 " Long
25	25 mm Long (Available with D Bushing Only)

RESOLUTION	
Code	PPR
1	32
2	64
3	128
4	256

BUSHING DESIGNATOR	
Code	Description
S	3/8 " D X 3/8 " L Threaded (Single Ball Bearing)
T	3/8 " D X 3/8 " L Threaded (Dual Ball Bearing)
W	Servo Mount 7/8 " D (Dual Ball Bearing)
D	9 mm D X 7.94 mm L Threaded (Single Ball Bearing)

TERMINAL CONFIGURATION**	
Code	Description
L	Axial, Multi-Purpose Pin
M	Rear Ribbons Cable with Connector
W	Rear Ribbons Cable - No Connector

OUTPUT TYPE	
Code	Description
Q	Quadrature

* Shaft length measured from mounting surface.

** Standard ribbon cable is 10 inches long. Consult factory for other lengths.

REV. 07/12

Specifications are subject to change without notice.

Customers should verify actual device performance in their specific applications.

Компания «Life Electronics» занимается поставками электронных компонентов импортного и отечественного производства от производителей и со складов крупных дистрибьюторов Европы, Америки и Азии.

С конца 2013 года компания активно расширяет линейку поставок компонентов по направлению коаксиальный кабель, кварцевые генераторы и конденсаторы (керамические, пленочные, электролитические), за счёт заключения дистрибьюторских договоров

Мы предлагаем:

- Конкурентоспособные цены и скидки постоянным клиентам.
- Специальные условия для постоянных клиентов.
- Подбор аналогов.
- Поставку компонентов в любых объемах, удовлетворяющих вашим потребностям.
- Приемлемые сроки поставки, возможна ускоренная поставка.
- Доставку товара в любую точку России и стран СНГ.
- Комплексную поставку.
- Работу по проектам и поставку образцов.
- Формирование склада под заказчика.
- Сертификаты соответствия на поставляемую продукцию (по желанию клиента).
- Тестирование поставляемой продукции.
- Поставку компонентов, требующих военную и космическую приемку.
- Входной контроль качества.
- Наличие сертификата ISO.

В составе нашей компании организован Конструкторский отдел, призванный помогать разработчикам, и инженерам.

Конструкторский отдел помогает осуществить:

- Регистрацию проекта у производителя компонентов.
- Техническую поддержку проекта.
- Защиту от снятия компонента с производства.
- Оценку стоимости проекта по компонентам.
- Изготовление тестовой платы монтаж и пусконаладочные работы.



Тел: +7 (812) 336 43 04 (многоканальный)

Email: org@lifeelectronics.ru