

# BMF055

## Custom programmable 9-axis motion sensor

Bosch Sensortec



**BOSCH**

Invented for life

### **BMF055: data sheet**

Document revision 0.1

Document release date November 2015

Document number BST-BMF055-DS000-01

Technical reference code(s) 0 273 141 235

Notes Data in this document are subject to change without notice. Product photos and pictures are for illustration purposes only and may differ from the real product's appearance.

# BMF055

## Custom programmable 9-axis motion sensor

### Basic Description

#### Key features:

- 3 sensors in one device an advanced triaxial 16bit gyroscope, a versatile, leading edge triaxial 14bit accelerometer and a full performance geomagnetic sensor
- Small package LGA package 28 pins  
Footprint 3.8 x 5.2 mm<sup>2</sup>, height 1.13 mm<sup>2</sup>
- Common voltage supplies V<sub>DD</sub> voltage range: 2.4V to 3.6V
- Consumer electronics suite MSL1, RoHS compliant, halogen-free  
Operating temperature: -40°C ... +85°C

#### Key features of integrated sensors:

##### Accelerometer features

- Programmable functionality Acceleration ranges  $\pm 2g/\pm 4g/\pm 8g/\pm 16g$   
Low-pass filter bandwidths 1kHz - <8Hz  
Operation modes:
  - Normal
  - Suspend
  - Low power
  - Standby
  - Deep suspend
- On-chip interrupt controller Motion-triggered interrupt-signal generation for
  - any-motion (slope) detection
  - slow or no motion recognition
  - high-g detection

### Gyroscope features

- Programmable functionality
  - Ranges switchable from  $\pm 125^\circ/\text{s}$  to  $\pm 2000^\circ/\text{s}$
  - Low-pass filter bandwidths 523Hz - 12Hz
  - Operation modes:
    - Normal
    - Fast power up
    - Deep suspend
    - Suspend
    - Advanced power save
- On-chip interrupt controller
  - Motion-triggered interrupt-signal generation for
    - any-motion (slope) detection
    - high rate

### Magnetometer features

- Flexible functionality
  - Magnetic field range typical  $\pm 1300\mu\text{T}$  (x-, y-axis);  $\pm 2500\mu\text{T}$  (z-axis)
  - Magnetic field resolution of  $\sim 0.3\mu\text{T}$
  - Operating modes:
    - Low power
    - Regular
    - Enhanced regular
    - High Accuracy
  - Power modes:
    - Normal
    - Sleep
    - Suspend
    - Force

### Typical applications

- Navigation
- Robotics
- Fitness and well-being
- Augmented reality
- Context awareness
- Tablets and ultra-books

## General description

The BMF055 is a System in Package (SiP), integrating a triaxial 14-bit accelerometer, a triaxial 16-bit gyroscope with a range of  $\pm 2000$  degrees per second, a triaxial geomagnetic sensor and a 32-bit cortex M0+ microcontroller in a single package.

The corresponding chip-sets are integrated into one single 28-pin LGA 3.8mm x 5.2mm x 1.1 mm housing.

## Contents

<b>BASIC DESCRIPTION</b> .....	<b>2</b>
<b>1. SPECIFICATION</b> .....	<b>7</b>
1.1 ELECTRICAL SPECIFICATION .....	7
1.2 ELECTRICAL AND PHYSICAL CHARACTERISTICS, MEASUREMENT PERFORMANCE.....	8
<b>2. ABSOLUTE MAXIMUM RATINGS</b> .....	<b>12</b>
<b>3. FUNCTIONAL DESCRIPTION</b> .....	<b>13</b>
3.1 ARCHITECTURE .....	13
3.2 POWER MANAGEMENT .....	13
<b>4. ACCELEROMETER</b> .....	<b>14</b>
<b>5. GYROSCOPE</b> .....	<b>14</b>
<b>6. MAGNETOMETER</b> .....	<b>14</b>
<b>7. MICROCONTROLLER</b> .....	<b>14</b>
<b>8. SYSTEM SETUP</b> .....	<b>15</b>
8.1 INTERNAL SENSOR CONNECTION .....	15
8.2 PROGRAMMING AND DEBUG INTERFACE .....	15
8.3 SENSING AXES ORIENTATION .....	15
<b>9. PIN-OUT AND CONNECTION DIAGRAM</b> .....	<b>16</b>
9.1 PIN DESCRIPTION .....	16
9.2 CONNECTION DIAGRAM .....	17
<b>10. PACKAGE</b> .....	<b>18</b>
10.1 OUTLINE DIMENSIONS .....	18
10.2 LANDING PATTERN RECOMMENDATION.....	19
10.3 MARKING .....	19
10.4 SOLDERING GUIDELINES .....	19
10.5 HANDLING INSTRUCTIONS.....	19
10.6 TAPE AND REEL SPECIFICATION .....	20
10.7 ENVIRONMENTAL SAFETY .....	20
10.7.1 HALOGEN CONTENT.....	20
<b>11. LEGAL DISCLAIMER</b> .....	<b>21</b>
11.1 ENGINEERING SAMPLES .....	21



11.2 PRODUCT USE..... 21

11.3 APPLICATION EXAMPLES AND HINTS..... 21

**12. DOCUMENT HISTORY AND MODIFICATIONS..... 22**

# 1. Specification

If not stated otherwise, the given values are over lifetime and full performance temperature and voltage ranges, minimum/maximum values are  $\pm 3$  sigma.

## 1.1 Electrical specification

Table 1-1: Electrical parameter specification

OPERATING CONDITIONS BMF055						
Parameter	Symbol	Condition	Min	Typ	Max	Unit
Supply Voltage (only Sensors)	$V_{DD}$	--	2.4	--	3.6	V
Supply Voltage ( $\mu$ C and I/O Domain)	$V_{DDIO}$	--	1.7	--	3.6	V
Voltage Input Low Level (UART, I2C)	$V_{DDIO\_VIL}$	$V_{DDIO} = 1.7-2.7V$	--	--	0.25	$V_{DDIO}$
		$V_{DDIO} = 2.7-3.6V$	--	--	0.3	$V_{DDIO}$
Voltage Input High Level (UART, I2C)	$V_{DDIO\_VIH}$	$V_{DDIO} = 1.7-2.7V$	0.7	--	--	$V_{DDIO}$
		$V_{DDIO} = 2.7-3.6V$	0.55	--	--	$V_{DDIO}$
Voltage Output Low Level (UART, I2C)	$V_{DDIO\_VOL}$	$V_{DDIO} > 3V, I_{OL} = 20mA$	--	0.1	0.2	$V_{DDIO}$
Voltage Output High Level (UART, I2C)	$V_{DDIO\_VOH}$	$V_{DDIO} > 3V, I_{OH} = 10mA$	0.9	0.8	--	$V_{DDIO}$
POR Voltage threshold on VDDIO-IN rising	$V_{DDIO\_POT+}$	$V_{DDIO}$ falls at 1V/ms or slower	--	1.45	--	V
POR Voltage threshold on VDDIO-IN falling	$V_{DDIO\_POT-}$		--	0.99	--	V
Operating Temperature	$T_A$	Min and Max are in this case simply min and max and not 3s values	-40	--	+85	$^{\circ}C$

Note: Since the resulting total supply current is subject to vary depending on the custom specific firmware which runs in the sensor, there is no information mentioned for current consumption. For additional information with respect to the individual sensors (accelerometer, gyroscope and magnetometer) and to the MCU please refer the respective datasheet.

## Electrical and physical characteristics, measurement performance

Table 1-2: Electrical characteristics BMF055

OPERATING CONDITIONS ACCELEROMETER						
Parameter	Symbol	Condition	Min	Typ	Max	Units
Acceleration Range	$g_{FS2g}$	Selectable via serial digital interface		±2		g
	$g_{FS4g}$			±4		g
	$g_{FS8g}$			±8		g
	$g_{FS16g}$			±16		g
OUTPUT SIGNAL ACCELEROMETER						
Parameter	Symbol	Condition	Min	Typ	Max	Units
Sensitivity	S	All $g_{FSxg}$ Values, $T_A=25^\circ\text{C}$		1		LSB/mg
Sensitivity tolerance	$S_{tol}$	$T_A=25^\circ\text{C}$ , $g_{FS2g}$		±1	±4	%
Sensitivity Temperature Drift	TCS	$g_{FS2g}$ , Nominal $V_{DD}$ supplies, Temp operating conditions		±0.03	±0.02	%/K
Sensitivity Supply Volt. Drift	$S_{VDD}$	$g_{FS2g}$ , $T_A=25^\circ\text{C}$ , $V_{DD\_min} \leq V_{DD} \leq V_{DD\_max}$		0.05	0.2	%/V
Zero-g Offset (x,y,z)	$Off_{xyz}$	$g_{FS2g}$ , $T_A=25^\circ\text{C}$ , nominal $V_{DD}$ supplies, over life-time	-150	±80	+150	mg
Zero-g Offset Temperature Drift	TCO	$g_{FS2g}$ , Nominal $V_{DD}$ supplies		±1	+/-3.5	mg/K
Zero-g Offset Supply Volt. Drift	$Off_{VDD}$	$g_{FS2g}$ , $T_A=25^\circ\text{C}$ , $V_{DD\_min} \leq V_{DD} \leq V_{DD\_max}$		0.5		mg/V
Bandwidth	$bw_8$	2 <sup>nd</sup> order filter, bandwidth programmable		8		Hz
	$bw_{16}$			16		Hz
	$bw_{31}$			31		Hz
	$bw_{63}$			63		Hz
	$bw_{125}$			125		Hz
	$bw_{250}$			250		Hz
	$bw_{500}$			500		Hz
	$bw_{1000}$			1,000		Hz
Nonlinearity	NL	best fit straight line, $g_{FS2g}$		±0.5	+/-2	%FS
Output Noise Density	$n_{rms}$	$g_{FS2g}$ , $T_A=25^\circ\text{C}$ Nominal $V_{DD}$ supplies Normal mode		150	190	$\mu\text{g}/\sqrt{\text{Hz}}$
MECHANICAL CHARACTERISTICS ACCELEROMETER						
Parameter	Symbol	Condition	Min	Typ	Max	Units
Cross Axis Sensitivity	CAS	relative contribution between any two of the three axes		1	2	%
Alignment Error	$E_A$	relative to package outline		±0.5	2	°



**OPERATING CONDITIONS GYROSCOPE**

Parameter	Symbol	Condition	Min	Typ	Max	Unit
Rate Range	R <sub>FS125</sub>	Selectable via serial digital interface		125		%/s
	R <sub>FS250</sub>			250		%/s
	R <sub>FS500</sub>			500		%/s
	R <sub>FS1000</sub>			1,000		%/s
	R <sub>FS2000</sub>			2,000		%/s

**OUTPUT SIGNAL GYROSCOPE**

Sensitivity via register Map	S	T <sub>A</sub> =25°C		16.0 900		LSB/%s rad/s
Sensitivity tolerance	S <sub>tol</sub>	T <sub>A</sub> =25°C, R <sub>FS2000</sub>	--	±1	±3	%
Sensitivity Change over Temperature	TCS	Nominal V <sub>DD</sub> supplies -40°C ≤ T <sub>A</sub> ≤ +85°C R <sub>FS2000</sub>		±0.03	±0.07	%/K
Sensitivity Supply Volt. Drift	S <sub>VDD</sub>	T <sub>A</sub> =25°C, V <sub>DD_min</sub> ≤ V <sub>DD</sub> ≤ V <sub>DD_max</sub>		<0.4		%/V
Nonlinearity	NL	best fit straight line R <sub>FS1000</sub> , R <sub>FS2000</sub>		±0.05	±0.2	%FS
Zero-rate Offset	Off Ω <sub>x</sub> , Ω <sub>y</sub> and Ω <sub>z</sub>	Nominal V <sub>DD</sub> supplies T <sub>A</sub> =25°C, Slow and fast offset cancellation off	-3	±1	+3	%/s
Zero-Ω Offset Change over Temperature	TCO	Nominal V <sub>DD</sub> supplies -40°C ≤ T <sub>A</sub> ≤ +85°C R <sub>FS2000</sub>		±0.015	±0.03	%/s per K
Zero-Ω Offset Supply Volt. Drift	OffΩ <sub>VDD</sub>	T <sub>A</sub> =25°C, V <sub>DD_min</sub> ≤ V <sub>DD</sub> ≤ V <sub>DD_max</sub>		0.1		%/s /V
Output Noise	n <sub>rms</sub>	rms, BW=47Hz (@ 0.014°/s/√Hz)		0.1	0.3	%/s

Bandwidth BW	f -3dB			523 230 116 64 47 32 23 12		Hz
--------------	-----------	--	--	---	--	----

**MECHANICAL CHARACTERISTICS GYROSCOPE**

Cross Axis Sensitivity	CAS	Sensitivity to stimuli in non-sense-direction		±1	±3	%
------------------------	-----	---	--	----	----	---

**OPERATING CONDITIONS MAGNETOMETER**

Parameter	Symbol	Condition	Min	Typ	Max	Units
Magnetic field range <sup>1</sup>	Brg,xy	TA=25°C	±1200	±1300		μT
	Brg,z		±2000	±2500		μT
Magnetometer heading accuracy <sup>2</sup>	As heading	30μT horizontal geomagnetic field component, TA=25°C			±2.5	deg

**MAGNETOMETER OUTPUT SIGNAL**

Parameter	Symbol	Condition	Min	Typ	Max	Unit
Device Resolution	D <sub>res,m</sub>	TA=25°C		0.3		μT
Gain error <sup>3</sup>	G <sub>err,m</sub>	After API compensation TA=25°C Nominal V <sub>DD</sub> supplies		±5	±8	%
Sensitivity Temperature Drift	TCS <sub>m</sub>	After API compensation -40°C ≤ TA ≤ +85°C Nominal V <sub>DD</sub> supplies		±0.01	±0.03	%/K
Zero-B offset	OFF <sub>m</sub>	TA=25°C		±40		μT
Zero-B offset Temperature Drift	TCO <sub>m</sub>	-40°C ≤ TA ≤ +85°C		±0.23	±0.37	μT/K
Full-scale Nonlinearity	NL <sub>m, FS</sub>	best fit straight line			1	%FS

<sup>1</sup> Full linear measurement range considering sensor offsets.

<sup>2</sup> The heading accuracy depends on hardware and software. A fully calibrated sensor and ideal tilt compensation are assumed.

<sup>3</sup> Definition:  $gain\ error = (measured\ field\ after\ API\ compensation) / (applied\ field) - 1$



Output Noise	$n_{rms,lp,m,xy}$	Low power preset x, y-axis, $T_A=25^\circ\text{C}$ Nominal $V_{DD}$ supplies		1.0		$\mu\text{T}$
	$n_{rms,lp,m,z}$	Low power preset z-axis, $T_A=25^\circ\text{C}$ Nominal $V_{DD}$ supplies		1.4		$\mu\text{T}$
	$n_{rms,rg,m}$	Regular preset $T_A=25^\circ\text{C}$ Nominal $V_{DD}$ supplies		0.6		$\mu\text{T}$
	$n_{rms,eh,m}$	Enhanced regular preset $T_A=25^\circ\text{C}$ Nominal $V_{DD}$ supplies		0.5		$\mu\text{T}$
	$n_{rms,ha,m}$	High accuracy preset $T_A=25^\circ\text{C}$ Nominal $V_{DD}$ supplies		0.3		$\mu\text{T}$
Power Supply Rejection Rate	$\text{PSRR}_m$	$T_A=25^\circ\text{C}$ Nominal $V_{DD}$ supplies		$\pm 0.5$		$\mu\text{T/V}$

## 2. Absolute Maximum Ratings

Table 2-1: Absolute maximum ratings (preliminary target values)

Parameter	Symbol	Condition	Min	Max	Units
Voltage at Supply Pin	$V_{DD}$ Pin		-0.3	4.2	V
	$V_{DDIO}$ Pin		-0.3	3.6	V
Voltage at any Logic Pin	$V_{non-supply}$ Pin		-0.3	$V_{DDIO}+0.3$	V
Passive Storage Temp. Range	Trps	≤ 65% rel. H.	-50	+150	°C
Mechanical Shock	MechShock <sub>200µs</sub>	Duration ≤ 200µs		10,000	g
	MechShock <sub>1ms</sub>	Duration ≤ 1.0ms		2,000	g
	MechShock <sub>freefall</sub>	Free fall onto hard surfaces		1.8	m
ESD	ESD <sub>HBM</sub>	HBM, at any Pin		2	kV
	ESD <sub>CDM</sub>	CDM		400	V
	ESD <sub>MM</sub>	MM		200	V

### **Note:**

Stress above these limits may cause damage to the device. Exceeding the specified electrical limits may affect the device reliability or cause malfunction.

## 3. Functional Description

### 3.1 Architecture

The following figure shows the basic building blocks of the BMF055 device.

Figure 1: system architecture

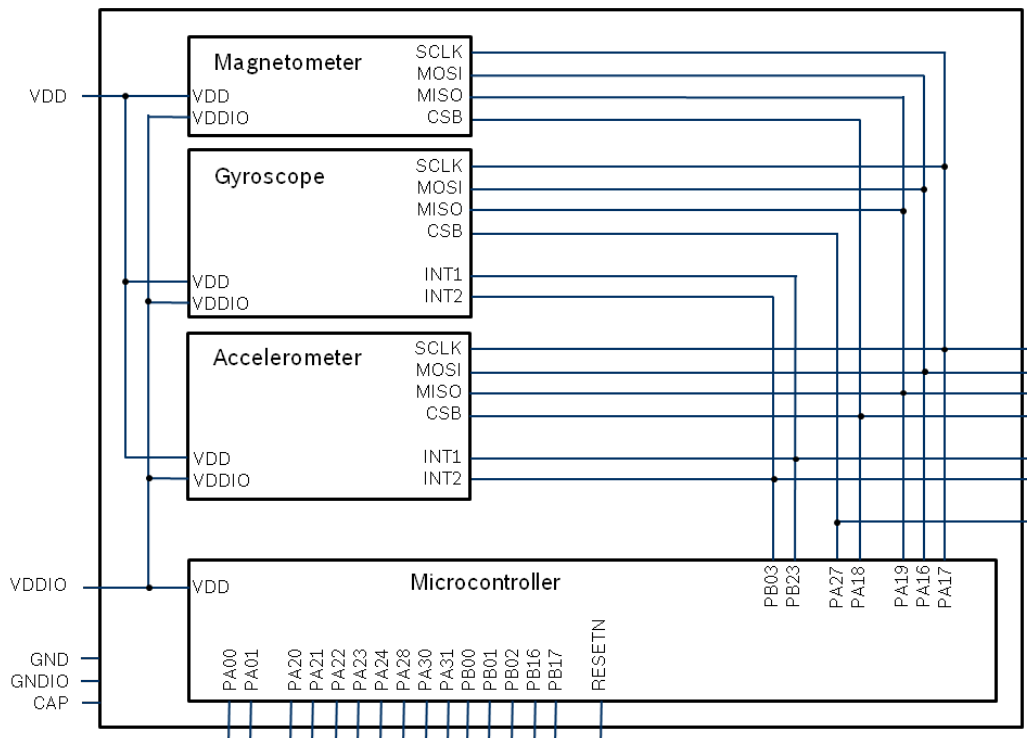

### 3.2 Power management

The BMF055 has two distinct power supply pins:

- $V_{DD}$  is the main power supply for the internal sensors
- $V_{DDIO}$  is a separate power supply pin used for the supply of the  $\mu C$  and the digital interfaces

For the switching sequence of power supply  $V_{DD}$  and  $V_{DDIO}$  it is mandatory that  $V_{DD}$  is powered on and driven to the specified level before or at the same time as  $V_{DDIO}$  is powered ON. Otherwise there are no limitations on the voltage levels of both pins relative to each other, as long as they are used within the specified operating range.

When the  $V_{DDIO}$  supply is switched off, all interface pins (CSB, MOSI, MISO, SCLK) must be kept close to  $GND_{IO}$  potential.

## 4. Accelerometer

The accelerometer built into the BMF055 is equivalent to the [BMA280](#). Please refer to the appropriate [data sheet](#) of that sensor for the functional description.

The performance values of the in-built accelerometer differ from the values stated at the BMA280 data sheet and can be found in this document.

## 5. Gyroscope

The gyroscope built into the BMF055 is equivalent to the [BMG160](#). Please refer to the appropriate [data sheet](#) of that sensor for the functional description.

The performance values of the in-built gyroscope differ from the values stated at the BMG160 data sheet and can be found in this document.

## 6. Magnetometer

The magnetometer built into the BMF055 is equivalent to the [BMM150](#). Please refer to the appropriate [data sheet](#) of that sensor for the functional description.

The performance values of the in-built magnetometer differ from the values stated at the BMM150 data sheet and can be found in this document.

## 7. Microcontroller

The microcontroller built into the BMF055 is a **Cortex-M0+** from Atmel:

- Atmel product family / series: **SAMD20** (general purpose microcontroller)
- Flash memory size: **256kB**
- SRAM memory size: **32kB**

Please refer to the appropriate data sheet from Atmel ([SAM D20 datasheet](#)) for further information.

## 8. System setup

### 8.1 Internal sensor connection

The sensors are connected to the MCU via SPI interface.

### 8.2 Programming and debug interface

The MCU can be programmed and debugged via Atmel debugging tools using the SWD interface.

### 8.3 Sensing Axes Orientation

The axis orientation is shown below.

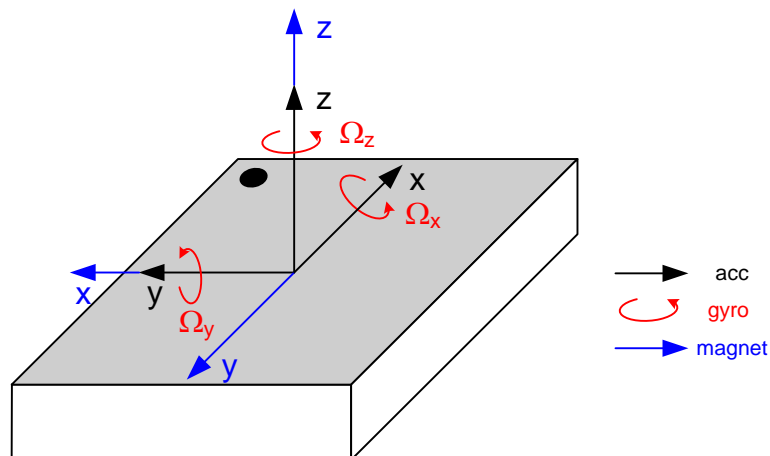

## 9. Pin-out and connection diagram

### 9.1 Pin description

If no port function is mentioned, the pin can be generally used as a general purpose IO. Details can be found in the Atmel SAM D20 datasheet. The pin names in this document are the same as in the microcontroller datasheet.

Pin No.	Pin Name	Internal connection	Port Function
1	PB03	X	Accelerometer / gyroscope INT2
2	GND	X	GND
3	VDD	X	VDD
4	PB02		
5	PB01		
6	PB00		
7	PA31		SWDIO
8	PA30		SWCLK
9	CAP		external capacitor
10	PA28		
11	RESETN		RESETN
12	PA27	X	Gyroscope CSB
13	PB23	X	Accelerometer / gyroscope INT1
14	PA24		
15	PA23		
16	PA22		
17	PA21		
18	PA20		
19	PB17		
20	PB16		
21	PA19	X	Internal SPI: MISO
22	PA18	X	Accelerometer / magnetometer CSB
23	PA17	X	Internal SPI: SCLK
24	PA16	X	Internal SPI: MOSI
25	GNDIO	X	GNDIO
26	PA01		optional: 32kHz Crystal Output
27	PA00		optional: 32kHz Crystal Input
28	VDDIO	X	VDDIO



## 9.2 Connection diagram

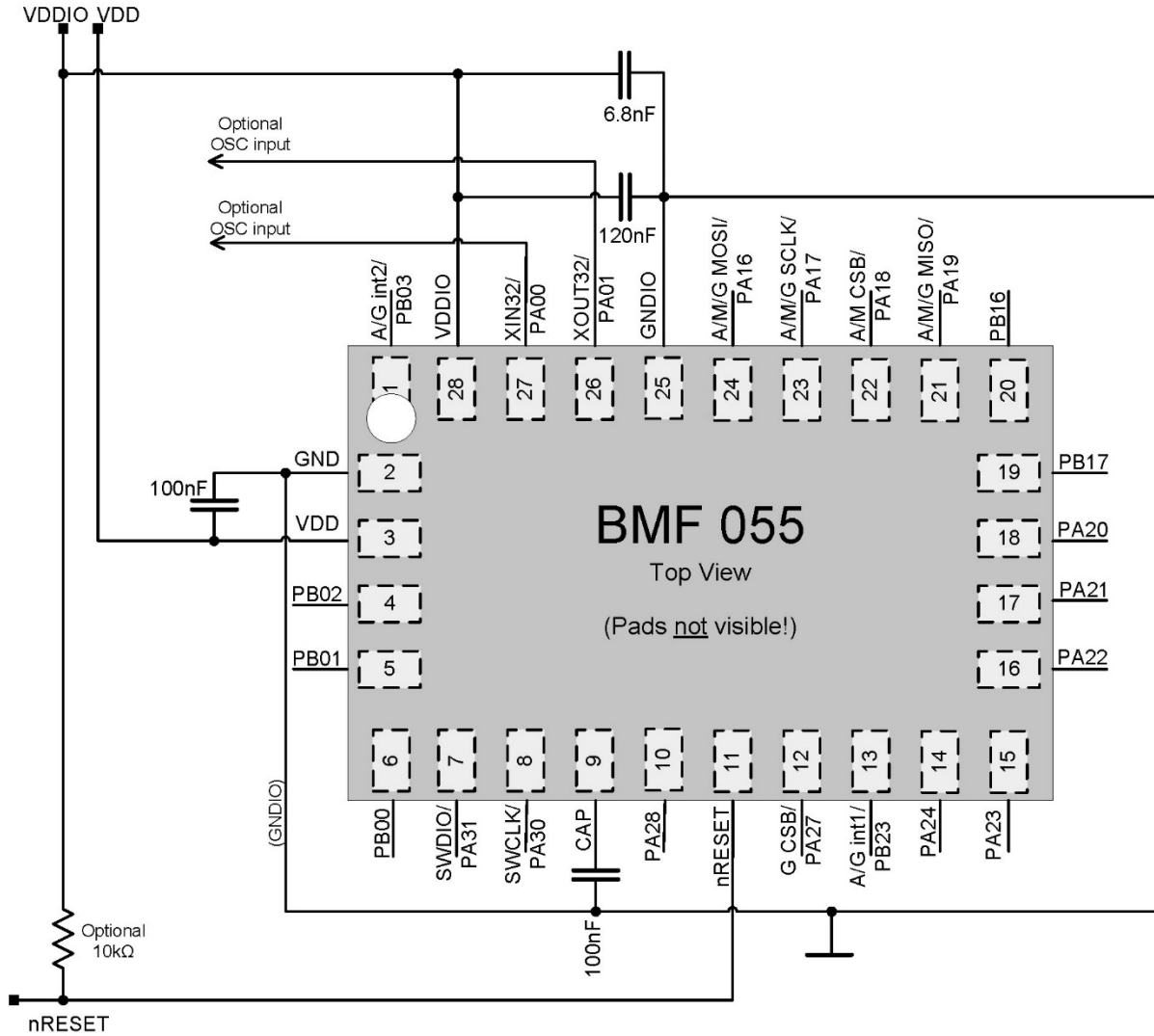

## 10. Package

### 10.1 Outline dimensions

The sensor package is a standard LGA package; dimensions are shown in the following diagram. Units are in mm. Note: Unless otherwise specified tolerance = decimal  $\pm 0.1$ mm.

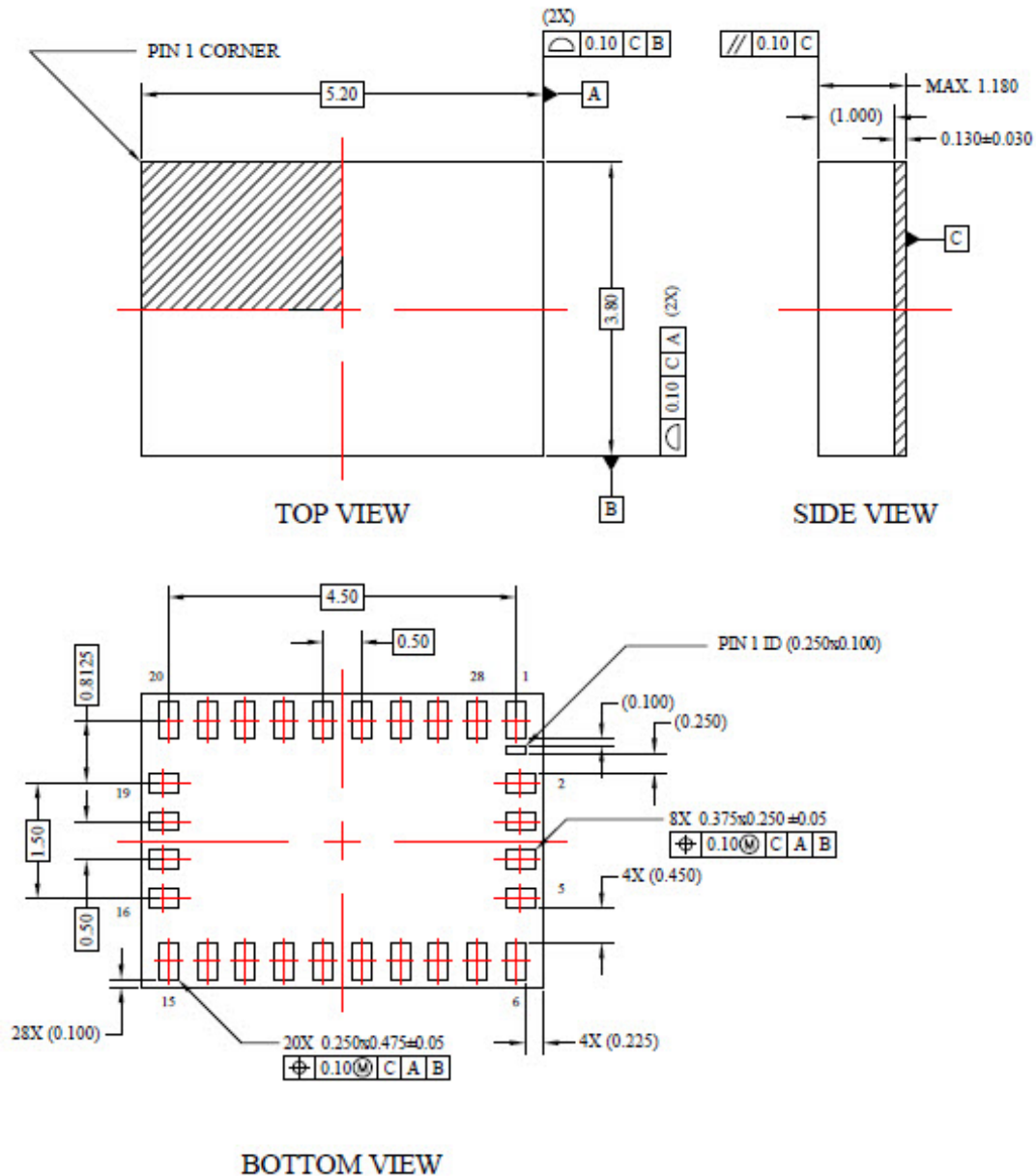

## 10.2 Landing pattern recommendation

Please refer to the Handling, mounting and soldering instructions document for BNO055.

## 10.3 Marking

Table 10-1: Marking of mass production parts

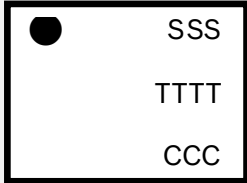
Labeling	Name	Symbol	Remark
	Pin 1 identifier	●	---
	First Row	S	Internal use
	Second Row	T	Internal use
	Third Row	C	Numerical counter

## 10.4 Soldering Guidelines

The moisture sensitivity level of the BMF055 sensors corresponds to JEDEC Level 1, see also

- IPC/JEDEC J-STD-020C "Joint Industry Standard: Moisture/Reflow Sensitivity Classification for non-hermetic Solid State Surface Mount Devices"
- IPC/JEDEC J-STD-033A "Joint Industry Standard: Handling, Packing, Shipping and Use of Moisture/Reflow Sensitive Surface Mount Devices"

The sensor fulfils the lead-free soldering requirements of the above-mentioned IPC/JEDEC standard, i.e. reflow soldering with a peak temperature up to 260°C.

## 10.5 Handling instructions

Micromechanical sensors are designed to sense acceleration with high accuracy even at low amplitudes and contain highly sensitive structures inside the sensor element. The MEMS sensor can tolerate mechanical shocks up to several thousand g's. However, these limits might be exceeded in conditions with extreme shock loads such as e.g. hammer blow on or next to the sensor, dropping of the sensor onto hard surfaces etc.

We recommend avoiding g-forces beyond the specified limits during transport, handling and mounting of the sensors in a defined and qualified installation process.

This device has built-in protections against high electrostatic discharges or electric fields (e.g. 2kV HBM); however, anti-static precautions should be taken as for any other CMOS component. Unless otherwise specified, proper operation can only occur when all terminal voltages are kept within the supply voltage range. Unused inputs must always be tied to a defined logic voltage level.

For more details on recommended handling, soldering and mounting please contact your local Bosch Sensortec sales representative and ask for the “Handling, soldering and mounting instructions” document.

### **10.6 Tape and reel specification**

The BMF055 is shipped in a standard cardboard box. For details please refer to the BNO055 shipment details document.

### **10.7 Environmental safety**

The BMF055 sensor meets the requirements of the EC restriction of hazardous substances (RoHS and RoHS2) directive, see also:

*Directive 2002/95/EC of the European Parliament and of the Council of 27 January 2003 on the restriction of the use of certain hazardous substances in electrical and electronic equipment.*

#### **10.7.1 Halogen content**

The BMF055 is halogen-free. For more details on the analysis results please contact your Bosch Sensortec representative.

## 11. Legal disclaimer

### 11.1 Engineering samples

Engineering Samples are marked with an asterisk (\*) or (e) or (E). Samples may vary from the valid technical specifications of the product series contained in this data sheet. They are therefore not intended or fit for resale to third parties or for use in end products. Their sole purpose is internal client testing. The testing of an engineering sample may in no way replace the testing of a product series. Bosch Sensortec assumes no liability for the use of engineering samples. The Purchaser shall indemnify Bosch Sensortec from all claims arising from the use of engineering samples.

### 11.2 Product use

Bosch Sensortec products are developed for the consumer goods industry. They may only be used within the parameters of this product data sheet. They are not fit for use in life-sustaining or security sensitive systems. Security sensitive systems are those for which a malfunction is expected to lead to bodily harm or significant property damage. In addition, they are not fit for use in products which interact with motor vehicle systems.

The resale and/or use of products are at the purchaser's own risk and his own responsibility. The examination of fitness for the intended use is the sole responsibility of the Purchaser.

The purchaser shall indemnify Bosch Sensortec from all third party claims arising from any product use not covered by the parameters of this product data sheet or not approved by Bosch Sensortec and reimburse Bosch Sensortec for all costs in connection with such claims.

The purchaser must monitor the market for the purchased products, particularly with regard to product safety, and inform Bosch Sensortec without delay of all security relevant incidents.

### 11.3 Application examples and hints

With respect to any examples or hints given herein, any typical values stated herein and/or any information regarding the application of the device, Bosch Sensortec hereby disclaims any and all warranties and liabilities of any kind, including without limitation warranties of non-infringement of intellectual property rights or copyrights of any third party. The information given in this document shall in no event be regarded as a guarantee of conditions or characteristics. They are provided for illustrative purposes only and no evaluation regarding infringement of intellectual property rights or copyrights or regarding functionality, performance or error has been made.

## 12. Document history and modifications

Rev. No	Chapter	Description of modification/changes	Date
0.1		Initial version	2015-11-16

Bosch Sensortec GmbH  
Gerhard-Kinder-Strasse 9  
72770 Reutlingen/ Germany

[contact@bosch-sensortec.com](mailto:contact@bosch-sensortec.com)  
[www.bosch-sensortec.com](http://www.bosch-sensortec.com)

Modifications reserved | Printed in Germany  
Specifications subject to change without notice  
Document number: BST-BMF055-DS000-01  
Revision\_0.1

# Mouser Electronics

Authorized Distributor

Click to View Pricing, Inventory, Delivery & Lifecycle Information:

[Bosch:](#)

[BMF055](#)

Компания «Life Electronics» занимается поставками электронных компонентов импортного и отечественного производства от производителей и со складов крупных дистрибьюторов Европы, Америки и Азии.

С конца 2013 года компания активно расширяет линейку поставок компонентов по направлению коаксиальный кабель, кварцевые генераторы и конденсаторы (керамические, пленочные, электролитические), за счёт заключения дистрибьюторских договоров

Мы предлагаем:

- Конкурентоспособные цены и скидки постоянным клиентам.
- Специальные условия для постоянных клиентов.
- Подбор аналогов.
- Поставку компонентов в любых объемах, удовлетворяющих вашим потребностям.
- Приемлемые сроки поставки, возможна ускоренная поставка.
- Доставку товара в любую точку России и стран СНГ.
- Комплексную поставку.
- Работу по проектам и поставку образцов.
- Формирование склада под заказчика.
- Сертификаты соответствия на поставляемую продукцию (по желанию клиента).
- Тестирование поставляемой продукции.
- Поставку компонентов, требующих военную и космическую приемку.
- Входной контроль качества.
- Наличие сертификата ISO.

В составе нашей компании организован Конструкторский отдел, призванный помогать разработчикам, и инженерам.

Конструкторский отдел помогает осуществить:

- Регистрацию проекта у производителя компонентов.
- Техническую поддержку проекта.
- Защиту от снятия компонента с производства.
- Оценку стоимости проекта по компонентам.
- Изготовление тестовой платы монтаж и пусконаладочные работы.



Тел: +7 (812) 336 43 04 (многоканальный)

Email: [org@lifeelectronics.ru](mailto:org@lifeelectronics.ru)