

IBS RL 24 DIO 8/8/8-T

Digital Input/Output Module With Eight Inputs and Eight Outputs

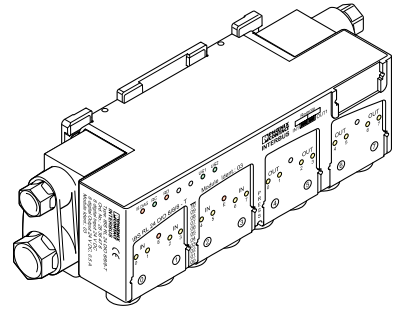

Data Sheet 5632B

04/2000

Product Description

The module is designed for use in systems engineering. With IP 67 protection, it is suitable for use without a control cabinet in harsh industrial conditions. It can, for example, be used on the tool platforms, directly on welding robots, or in conveying systems.

Depending on the application area, this module allows you to connect the bus and the power supply to the module from two sides.

QUICKON bus connectors are used to feed the module with the power supply for the bus logic/sensors (24 V DC) and actuators (24 V DC).

Features

- INTERBUS protocol (EN 50254)
- IP 67 protection
- Bus connection using copper cables
- QUICKON connectors for the supply voltage
- Sensors and actuators are connected using 5-pos. M12 female connectors
- Installation options:
 - directly to the welding robot
 - on aluminum mounting channels
 - two-position attachment
 - direct mounting

Note



This data sheet is intended to be used in conjunction with the Rugged Line I/O Systems Manual IBS RL SYS PRO UM E.



Note that the bus connectors and the mounting plate are not supplied as standard (see Ordering Data page 14).



Only connect and remove the bus connector when power has been disconnected. (Connection according to DIN EN 60204-1:1993-06.)



To ensure IP 67 protection you must note the following points:

- The bus connectors must be connected.
- You must not pierce the grommet of unused bus connectors. (You will, for example, have unused connections if the module is the last device in the bus system.)
- Cover unused M12 female connectors with protective caps.

Connector Pin Assignment

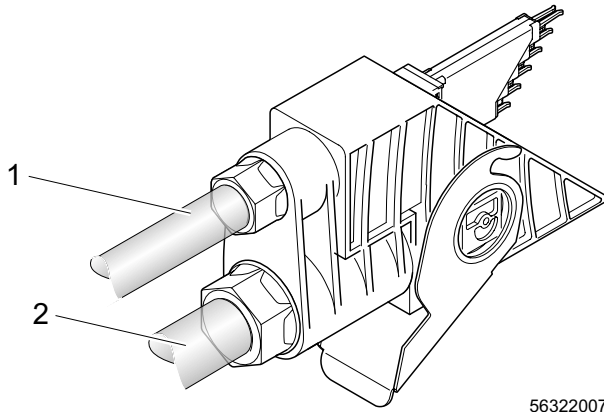

56322007

Figure 1 Connector pin assignment of the incoming or outgoing bus

- 1 INTERBUS remote bus
- 2 U_{S1}/U_{S2} power supply
 U_{S1} = bus/sensor supply
 U_{S2} = actuator supply



All U_{S1} and U_{S2} contacts are rated 16 Amps.

INTERBUS Remote Bus

| Position in Figure 1 | Signal | Connection Method | Wire Color | Designation |
|----------------------|--------|-------------------|------------|-------------|
| 1 | /DO | 1 | Green | GN |
| | DO | 2 | Yellow | YE |
| | /DI | 3 | Pink | PK |
| | DI | 4 | Gray | GY |
| | GND | 5 | Brown | BN |

U_{S1}/U_{S2} Power Supply

| Position in Figure 1 | Signal | Connection Method | Wire Color | Des. |
|----------------------|-------------------------|-------------------|------------|------|
| 2 | +24 V U_{S1} | 1 | Black | 1 |
| | GND U_{S1} | 2 | Black | 2 |
| | +24 V U_{S2} | 3 | Black | 3 |
| | GND U_{S2} | 4 | Black | 4 |
| | Functional earth ground | 5 | Yellow | 5 |

Connection of Inputs and Outputs



Two inputs are assigned to each of the sockets 0 to 3; two outputs are assigned to sockets 4 to 7.



A concurrent channel derating of 50% applies to the outputs. This means only four outputs are allowed to carry the nominal current at the same time.

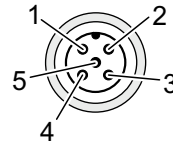
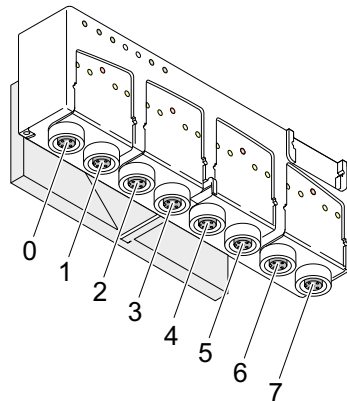

5501A005

Figure 2 Pin assignment of 5-pos. M12 sockets (1)

| Pin | Socket 0 | Socket 1 | Socket 2 | Socket 3 | Socket 4 | Socket 5 | Socket 6 | Socket 7 |
|-----|--------------------------------------|----------|----------|----------|------------------------|----------|----------|----------|
| 1 | U _{S1} -1 V (sensor supply) | | | | Ground U _{S2} | | | |
| 2 | IN 1 | IN 3 | IN 5 | IN 7 | OUT 1 | OUT 3 | OUT 5 | OUT 7 |
| 3 | Ground U _{S1} | | | | Ground U _{S2} | | | |
| 4 | IN 0 | IN 2 | IN 4 | IN 6 | OUT 0 | OUT 2 | OUT 4 | OUT 6 |
| 5 | Functional earth ground | | | | | | | |

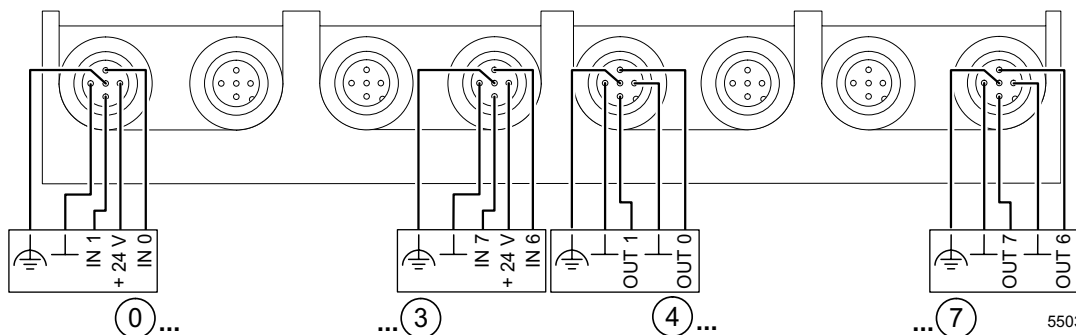

5503A004

Figure 3 Pin assignment of 5-pos. M12 sockets (2)

Electrical Isolation

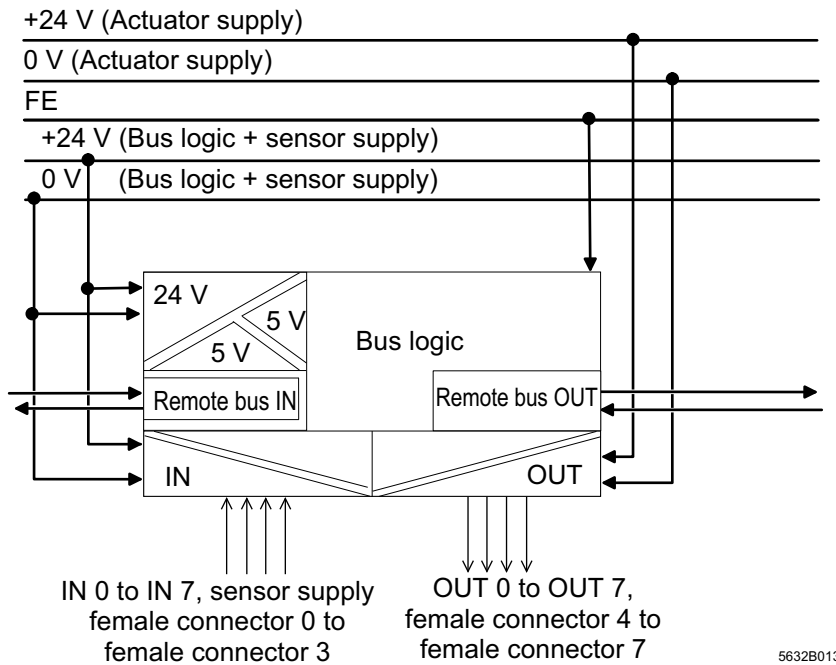

Figure 4 Block diagram

Programming Data

| | |
|-------------------------|---|
| ID code | 03 _{hex} (03 _{dec}) |
| Length code | 81 _{hex} (129 _{dec}) |
| Input address area | 1 bytes |
| Output address area | 1 bytes |
| Parameter channel (PCP) | Not present |
| Register length (bus) | 1 bytes |

Error Messages

- The breakdown of the sensor supply for a group of four inputs is indicated to the control or computer system (through the bus). The breakdown is stored in the module.
- The bus delivers a short-circuit or overload message to the control or computer system. These messages are stored in the module.
- The bus indicates to the control or computer system that the supply voltage U_{S1} has dropped below the permissible range.
- Upon delivery the module is set up so that errors concerning the supply voltage U_{S1} , the sensor supply or the outputs are indicated via the bus.
If the supply voltage U_{S2} is not present or is below the permissible voltage range this is not indicated but only displayed by the US2 LED.
- The error messages are reset through acknowledgment in the control or computer system.
- The configuration data and the error messages (except for undervoltage diagnostics) are only stored in the volatile memory of the module. Configuration data and error messages are deleted when the power is reset.

Assignment to the INTERBUS Input Data Word

| (Byte.bit) view | Byte | Byte 0 | | | | | | | | Byte 1 | | | | | | | |
|--------------------|-------|---------------------|---|---|---|---|---|---|---|----------|---|---|---|---|---|---|---|
| | Bit | 7 | 6 | 5 | 4 | 3 | 2 | 1 | 0 | 7 | 6 | 5 | 4 | 3 | 2 | 1 | 0 |
| Terminal | Slot | 3 | 3 | 2 | 2 | 1 | 1 | 0 | 0 | Not used | | | | | | | |
| | Input | 7 | 6 | 5 | 4 | 3 | 2 | 1 | 0 | | | | | | | | |
| | | Status input 0 to 7 | | | | | | | | | | | | | | | |

Assignment of the Bits to the INTERBUS Output Data Word

| (Byte.bit) view | Byte | Byte 0 | | | | | | | | Byte 1 | | | | | | | |
|--------------------|--------|----------------------|---|---|---|---|---|---|---|----------|---|---|---|---|---|---|---|
| | Bit | 7 | 6 | 5 | 4 | 3 | 2 | 1 | 0 | 7 | 6 | 5 | 4 | 3 | 2 | 1 | 0 |
| Terminal | Slot | 7 | 7 | 6 | 6 | 5 | 5 | 4 | 4 | Not used | | | | | | | |
| | Output | 7 | 6 | 5 | 4 | 3 | 2 | 1 | 0 | | | | | | | | |
| | | Status output 0 to 7 | | | | | | | | | | | | | | | |



For the assignment of the illustrated (Byte.Bit) view for your control or computer system, please refer to data sheet DB GB IBS SYS ADDRESS, Part No. 90 00 99 0.

Status and Diagnostic Indicators

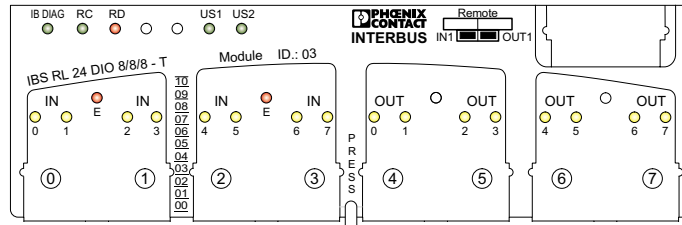

56322015

Figure 5 Position of the status and diagnostic indicators

| | | |
|----------------|---------------------|---|
| IB DIAG | Green LED | INTERBUS diagnostics |
| | OFF: | Supply voltage not present |
| | Flashing at 0.5 Hz: | Supply voltage present, bus not active |
| | Flashing at 2 Hz: | Supply voltage present, I/O error |
| | ON: | Supply voltage present, bus active, no I/O error |
| RC | Green LED | Remote bus cable check |
| | ON: | Incoming remote bus connection established |
| | OFF: | Incoming remote bus connection defective |
| RD | Red LED | Remote bus status (Remote Bus Disabled) |
| | ON: | Outgoing remote bus switched off |
| US1 | Green LED | Monitoring the supply voltage U_{S1} |
| | OFF: | U_{S1} not present |
| | Flashing: | U_{S1} below the permissible voltage range |
| | ON: | U_{S1} present |
| US2 | Green LED | Monitoring the supply voltage U_{S2} |
| | Flashing: | U_{S2} below the permissible voltage range / not present |
| | ON: | U_{S2} present |
| E | Red LED | Error message |
| | ON: | Short-circuit of the sensor supply for a group of four inputs. (This error message is stored temporarily on the module. It is stored in volatile memory and will be lost after power is reset.) |

- | | | |
|------------------|---|---|
| IN 0 -7 | Yellow LED ON: OFF: | Status per input Input at logic 1 Input at logic 0 |
| OUT 0 - 7 | Yellow/red LED Yellow: OFF: Red: | Status per output Output at logic 1 Output at logic 0 Short-circuit/overload of an output. (This error message is stored temporarily on the module. It is stored in volatile memory and will be lost after power is reset.) |

Housing Dimensions

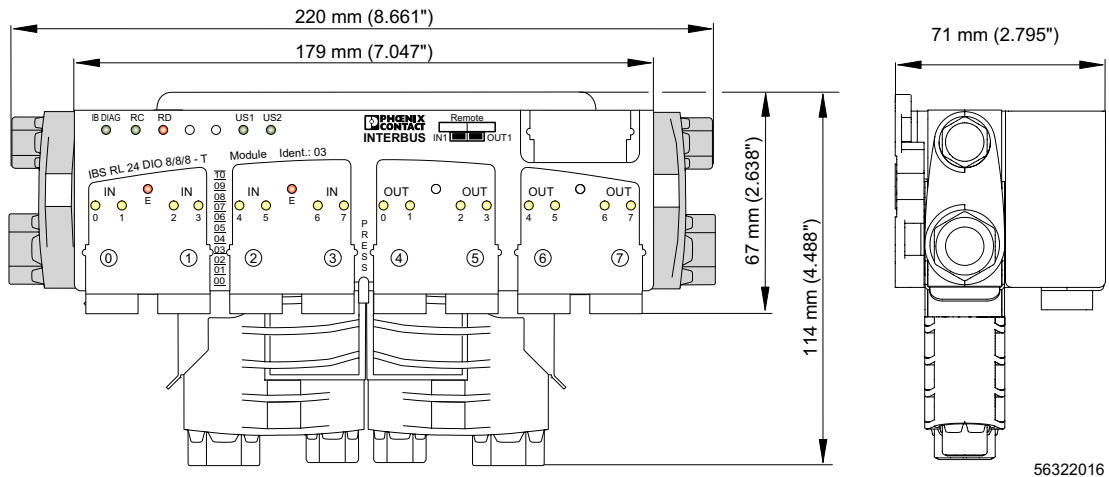





Figure 6 Housing dimensions



Technical Data

| General Data | |
|--|--|
| Ambient temperature | Operation: 0°C to +55°C (32°F to 131°F) Storage/transport: -25°C to +70°C (-13°F to 158°F) |
| Humidity | Operation: 100% Storage/transport: 95%, no condensation |
| Air pressure | Operation: 860 hPa to 1080 hPa (up to 1500 m [4921.260 ft.] above sea level) Storage/transport: 660 hPa to 1080 hPa (up to 3500 m [11,482.940 ft.] above sea level) |
| Degree of protection | IP 67 (when installed) Seal unused slots/connections to ensure IP 67 protection. |
| Material | Zinc die-cast Copper and nickel-plated surface |
| Electrical isolation between bus logic and I/O devices between bus logic and outputs | Test voltage 500 V AC, 50 Hz, 1 min Test voltage 500 V AC, 50 Hz, 1 min |
| Housing dimensions (width x height x depth) | 220 mm x 114 mm x 71 mm (8.661 in. x 4.488 in. x 2.795 in.) (with bus connector and mounting plate) |
| Weight | Approximately 720 g (without connector and mounting plate) |

| Supply Voltage U_{S1} (Bus Logic) | |
|--------------------------------------|--|
| Nominal voltage | 24 V DC |
| Permissible range | 18.5 V DC to 32 V DC (ripple included) |
| Ripple | 3.6 V _{pp} |
| Current consumption | 120 mA, typical, plus supply current for the sensors |
| Overvoltage protection | 35 V (0.5 s) |
| Protection against polarity reversal | Yes (diode connected in parallel) 20 A, 500 ms, typical |

| Supply Voltage U_{S1} (Bus Logic) (Continued) | |
|--|------------------------|
| External fuse | 5 A slow-blow, maximum |
|  Protection against polarity reversal is only effective if the module is externally protected. The power supply unit must be able to supply at least four times the rating of the external fuse. | |
|  The voltage U_{S1} is looped through and can be tapped off at the connector for the outgoing remote bus. The maximum continuous current must not exceed 16 A. | |

| Supply Voltage U_{S1} (Sensor Voltage) | |
|--|--|
|  The sensors are supplied in groups of four via a short-circuit-proof sensor supply. | |
| Nominal voltage | U_{S1} minus 1 V |
| Current consumption | 400 mA total current for all inputs (50 mA per input) |
| Protection | Electronic overload/short-circuit protection per group |

| Actuator Voltage U_{S2} | |
|--|--|
| Nominal voltage | 24 V DC |
| Permissible voltage range | 18.5 V DC to 32 V DC (ripple included) |
| Ripple | 3.6 V _{pp} |
| Current consumption | 2 A, maximum, note concurrent channel derating |
| Concurrent channel derating | 50% |
| Overvoltage protection | 35 V (0.5 s) |
| Protection against polarity reversal | Yes (diode connected in parallel) 20 A, 500 ms, typical |
| External fuse | 5 A slow-blow, maximum |
|  Protection against polarity reversal is only effective if the module is externally protected. The power supply unit must be able to supply at least four times the rating of the external fuse. | |
|  The voltage U_{S2} is looped through and can be tapped off at the connector for the outgoing remote bus. The maximum continuous current must not exceed 16 A. | |

| INTERBUS Interface | |
|---------------------------|---|
| Interface type | 2-wire installation remote bus Differential signal lines, twisted in pairs |
| Connection method | IP 67 connector |



| Digital Inputs | |
|---|--|
| Number of inputs | 8 |
| Electrical isolation between I/O devices and bus logic to the digital outputs | Test voltage 500 V AC, 50 Hz, 1 min Test voltage 500 V AC, 50 Hz, 1 min |
| Input voltage | According to DIN EN 61131-2 Permissible range 0 signal: 0 V to +5 V Permissible range 1 signal: 11 V to 30 V |
| Input current | 3 mA, typical |
| Permissible residual current, "0" signal | 1.5 mA, typical |
| Delay time 0 → 1 | 3 ms, typical |
| Delay time 1 → 0 | 3 ms, typical |

| Characteristic of the Inputs | |
|-------------------------------------|------------------------------------|
| Input Voltage (V) | Input Current (mA), Typical |
| $0 < U_{IN} < 0.7$ | 0 |
| 3 | 0.23 |
| 6 | 0.51 |
| 9 | 0.92 |
| 12 | 1.37 |
| 15 | 1.80 |
| 18 | 2.25 |
| 21 | 2.68 |
| 24 | 3.13 |
| 27 | 3.57 |
| 30 | 4.01 |

| Switching Threshold of the Inputs, Typical | | |
|--|-------------------|-----------------------------|
| Signal Transition | Input Voltage (V) | Input current (mA), Typical |
| 0 → 1 | 7.52 | 0.72 |
| 1 → 0 | 7.49 | 0.72 |

| Digital Outputs | |
|---|--|
| Number | 8 |
| Nominal output voltage U_{OUT} | 24 V DC |
| Differential voltage for I_{nom} | ≤ 1 V |
| Concurrent channel derating of the outputs | 50% |
| Nominal current I_{nom} per channel with derating and 50% coincidence | 0.5 A |
| Tolerance of the nominal current | +10% |
| Total current | 2 A |
| Contactors (four channels are thermally coupled, i.e., an error in one channel can affect the other channels of the group). | Short-circuit; overload |
| Nominal load | |
| Ohmic | 48 Ω / 12 W |
| Lamp | 12 W |
| Inductive | 12 VA (1.2 H, 48 Ω) |
| Signal delay upon power up of | |
| - Ohmic nominal load | 20 μ s, typical |
| - Lamp nominal load | 20 μ s, typical |
| - Inductive nominal load | 20 μ s (1.2 H, 48 Ω), typical |
| Signal delay: ON to OFF | |
| - Ohmic nominal load | 300 μ s, typical |
| - Lamp nominal load | 300 μ s, typical |
| - Inductive nominal load | 300 μ s, typical (1.2 H, 48 Ω) |

Digital Outputs (Continued)

| | |
|--|---|
| Switching frequency | |
| - Ohmic nominal load | 300 Hz, maximum |
|  This switching frequency is limited by the selected data rate, the number of bus devices, the bus structure, the software and the control or computer system used. | |
| - Lamp nominal load | 300 Hz, maximum |
|  This switching frequency is limited by the selected data rate, the number of bus devices, the bus structure, the software and the control or computer system used. | |
| - Inductive nominal load | 0.5 Hz (1.2 H; 48 Ω), maximum |
| Overload response | Auto restart |
| Response time with ohmic overload (12 Ω, 25°C [77°F]) | Approximately 3 s |
| Response after inductive overload | Output can be destroyed |
| Reverse voltage endurance against short pulses | Protection up to 2 A DC |
| Strength against permanently applied surge voltage | No |
| Limitation of the demagnetization voltage induced on circuit interruption | $U(\text{demag}) \leq -8 \text{ V}$ |
| Overvoltage disconnection | At 0.7 A, minimum |
| Output current when switched off | 100 μA, maximum |
| Output voltage when switched off | 1 V, maximum |
| Output current with ground connection interrupted | 25 mA, maximum |
| Switching power with ground connection interrupted | 100 mW at 1 kΩ load resistance, typical |

Output Characteristic When Switched On (Typical)

| Output Current (A) | Differential Output Voltage (V) |
|--------------------|---------------------------------|
| 0 | 0 |
| 0.1 | 0.04 |
| 0.2 | 0.08 |
| 0.3 | 0.12 |
| 0.4 | 0.16 |
| 0.5 | 0.20 |

Ordering Data

| Description | Order Designation | Order No. |
|--|-----------------------|------------|
| Digital input/output module | IBS RL 24 DIO 8/8/8-T | 28 36 47 6 |
| Bus connector (2 pcs. needed) | IBS RL PLUG-T | 27 31 89 8 |
| Mounting plate | IBS RL AP | 27 31 12 8 |
| Labeling fields (set of 50 pcs.) | IBS RL MARKER-SET | 27 32 72 9 |
| Protective caps (5 pcs.) for unused M12 connectors | IBS IP PROT IO | 27 59 91 9 |
| Rugged Line I/O Systems Manual | IBS RL SYS PRO UM E | 27 43 78 9 |
| 4-pos. sensor connector with QUICKON connection for M12 female sockets | SACC-M12MS-4QLCON | 16 40 22 3 |
| Remote bus cable for very flexible applications, welding-splash-resistant in standard applications | IBS RBC METER/F-T | 27 23 12 3 |
| Supply cable, 5 x 1.5 mm ² (16 AWG), gray, very flexible, welding-splash-resistant in standard applications | IBS PWR/5 HD/F | 28 36 15 9 |
| Supply cable, 5 x 1.5 mm ² (16 AWG) | IBS PWR/5 | 28 20 00 0 |
| Fiber cutter | IBS RL FOC | 27 25 14 7 |

© Phoenix Contact 04/2000 Subject to technical modification TNR 94 23 49 7

Компания «Life Electronics» занимается поставками электронных компонентов импортного и отечественного производства от производителей и со складов крупных дистрибьюторов Европы, Америки и Азии.

С конца 2013 года компания активно расширяет линейку поставок компонентов по направлению коаксиальный кабель, кварцевые генераторы и конденсаторы (керамические, пленочные, электролитические), за счёт заключения дистрибьюторских договоров

Мы предлагаем:

- Конкурентоспособные цены и скидки постоянным клиентам.
- Специальные условия для постоянных клиентов.
- Подбор аналогов.
- Поставку компонентов в любых объемах, удовлетворяющих вашим потребностям.
- Приемлемые сроки поставки, возможна ускоренная поставка.
- Доставку товара в любую точку России и стран СНГ.
- Комплексную поставку.
- Работу по проектам и поставку образцов.
- Формирование склада под заказчика.
- Сертификаты соответствия на поставляемую продукцию (по желанию клиента).
- Тестирование поставляемой продукции.
- Поставку компонентов, требующих военную и космическую приемку.
- Входной контроль качества.
- Наличие сертификата ISO.

В составе нашей компании организован Конструкторский отдел, призванный помогать разработчикам, и инженерам.

Конструкторский отдел помогает осуществить:

- Регистрацию проекта у производителя компонентов.
- Техническую поддержку проекта.
- Защиту от снятия компонента с производства.
- Оценку стоимости проекта по компонентам.
- Изготовление тестовой платы монтаж и пусконаладочные работы.



Тел: +7 (812) 336 43 04 (многоканальный)

Email: org@lifeelectronics.ru