

**DATA SHEET**

# SKY65342-11: 450-470 MHz Front-End Module

## Applications

- Tetra radio
- Remote metering
- GSM450
- WLL

## Features

- Transmit output power > +29 dBm
- High gain in transmit path = 32 dB
- High transmit/receive isolation > 30 dB
- Internal RF match and bias circuits
- Single DC supply : +3.6 V
- Small, MCM (12-pin, 8 x 8 mm) package (MSL3, 260 °C per JEDEC J-STD-020)

**NEW**

Skyworks offers lead (Pb)-free RoHS (Restriction of Hazardous Substances) compliant packaging.

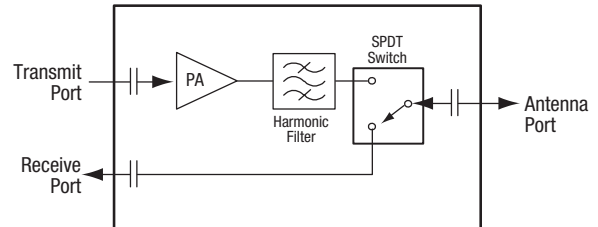

S1346

**Figure 1. SKY65342-11 Block Diagram**

## Description

The SKY65342-11 is a highly efficient Front-End Module (FEM) that incorporates a transmit/receive (T/R) path and an antenna T/R switch. The transmit path consists of a high efficiency power amplifier (PA) followed by a harmonic filter to reject harmonic frequencies. The PA is implemented using Skyworks highly reliable Heterojunction Bipolar Transistor (HBT) process and is Class AB biased to provide maximum efficiency with a low spurious output.

A high linearity and high isolation single-pole, double-throw (SPDT) switch is used at the common antenna interface between the transmit and receive paths. The receive path is a low insertion loss “through” path with input and output ports internally matched to 50 Ω.

The SKY65342-11 FEM uses Surface Mount Technology (SMT) in the form of a Multi-Chip Module (MCM), which allows for a highly manufacturable, low-cost solution. The device is provided as a compact, 12-pin 8 x 8 mm MCM. A functional block diagram is shown in Figure 1. The pin configuration and package are shown in Figure 2. Signal pin assignments and functional pin descriptions are provided in Table 1.

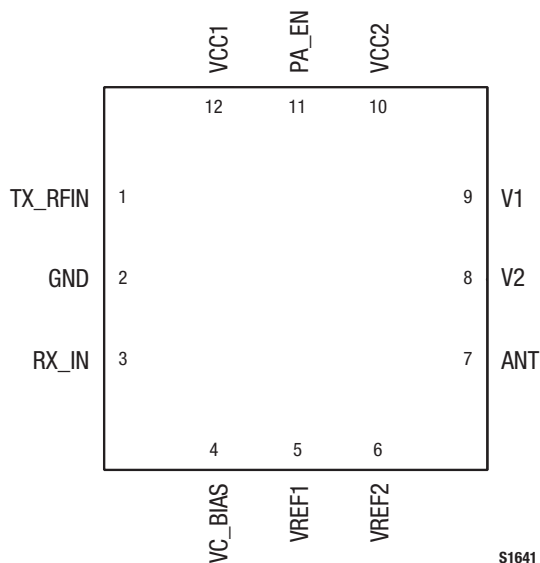

**Figure 2. SKY65342-11 Pinout – 12-Pin MCM (Top View)**

### Technical Description

The SKY65342-11 provides input and output amplifier stages, and is internally matched for optimum efficiency. An active bias circuit provides the input and output stages with excellent gain tracking over temperature and voltage variations. The module operates with positive DC voltages, and maintains high efficiency and good linearity. The nominal operating voltage is 3.6 V for maximum power, but the device can be operated at slightly lower voltages for other mobile applications.

The input and output stages are independently supplied using the VCC1 and VCC2 supply lines (pins 12 and 10, respectively). The bias reference voltages for stages 1 and 2 are supplied using common lines VREF1 and VREF2 (pins 5 and 6, respectively). The DC control voltage that sets the bias for stages 1 and 2 is supplied by the VC\_BIAS signal, pin 4.

### Electrical and Mechanical Specifications

Signal pin assignments and functional pin descriptions are described in Table 1. The absolute maximum ratings of the SKY65342-11 are provided in Table 2. The recommended operating conditions are specified in Table 3 and electrical specifications are provided in Table 4.

Typical performance characteristics of the SKY65342-11 are illustrated in Figures 3 through 7. The state of the SKY65342-11 is determined by the logic provided in Table 5.

### Package and Handling Information

Since the device package is sensitive to moisture absorption, it is baked and vacuum packed before shipping. Instructions on the shipping container label regarding exposure to moisture after the container seal is broken must be followed. Otherwise, problems related to moisture absorption may occur when the part is subjected to high temperature during solder assembly.

The SKY65342-11 is rated to Moisture Sensitivity Level 3 (MSL3) at 260 °C. It can be used for lead or lead-free soldering. For additional information, refer to Skyworks Application Note, *PCB Design and SMT Assembly/Rework Guidelines for MCM-L Packages*, document number 101752.

Care must be taken when attaching this product, whether it is done manually or in a production solder reflow environment. Production quantities of this product are shipped in a standard tape and reel format. For packaging details, refer to the Skyworks Application Note, *Tape and Reel Information – RF Modules*, document number 101568.

**Table 1. SKY65342-11 Signal Descriptions**

Pin #	Name	Description	Pin #	Name	Description
1	TX_RF1N	Transmit RF input	7	ANT	Antenna
2	GND	Ground	8	V2	Switch control
3	RX_IN	Receive RF input	9	V1	Switch control
4	VC_BIAS	+3.6 V DC supply	10	VCC2	+3.6 V DC supply
5	VREF1	+3.6 V DC supply	11	PA_EN	PA enable (on = 2.5-3.6 V, off = 0-0.2 V)
6	VREF2	+3.6 V DC supply	12	VCC1	+3.6 V DC supply

**Table 2. SKY65342-11 Absolute Maximum Ratings (Note 1)**

Parameter	Symbol	Minimum	Maximum	Units
Supply voltage (VCC1, VCC2, VREF1, VREF2, VC_BIAS)	V <sub>CC</sub>		4	V
Input power	P <sub>IN</sub>		+5	dBm
Supply current	I <sub>CC</sub>		850	mA
Case operating temperature	T <sub>C</sub>	-40	+85	°C
Storage temperature	T <sub>ST</sub>	-65	+125	°C
Junction temperature	T <sub>J</sub>		+150	°C

**Note 1:** Exposure to maximum rating conditions for extended periods may reduce device reliability. There is no damage to device with only one parameter set at the limit and all other parameters set at or below their nominal value. Exceeding any of the limits listed here may result in permanent damage to the device.

**CAUTION:** Although this device is designed to be as robust as possible, Electrostatic Discharge (ESD) can damage this device. This device must be protected at all times from ESD. Static charges may easily produce potentials of several kilovolts on the human body or equipment, which can discharge without detection. Industry-standard ESD precautions should be used at all times.

**Table 3. SKY65342-11 Recommended Operating Conditions**

Parameter	Symbol	Minimum	Typical	Maximum	Units
Supply voltage (VCC1, VCC2, VREF1, VREF2, VC_BIAS)	V <sub>CC</sub>	3.0	3.6	4.0	V
Case operating temperature	T <sub>C</sub>	-40		+85	°C
Storage temperature	T <sub>ST</sub>	-55		+125	°C

**Table 4. SKY65342-11 Electrical Specifications (Note 1)**  
**(Frequency = 460 MHz, VCC1 = VCC2 = VREF1 = VREF2 = VC\_BIAS = 3.6 V, Tc = +25 °C, Unless Otherwise Noted)**

Parameter	Symbol	Test Condition	Min	Typical	Max	Units
Operating frequency range	f		450		470	MHz
Transmit path small signal gain	G	CW, P <sub>IN</sub> = -30 dBm	30	34.6		dB
Transmit saturated output power	P <sub>SAT</sub>	CW, P <sub>IN</sub> = 0 dBm	+28.5	+29.1		dBm
Transmit path Noise Figure	NF			5.5	6.5	dB
Transmit path harmonics (2 <sup>nd</sup> to 6 <sup>th</sup> )		CW, P <sub>IN</sub> = 0 dBm	53	60		dBc
Power Added Efficiency	PAE	CW, P <sub>IN</sub> = 0 dBm	31	34		%
Receive path insertion loss	RX_LOSS			0.6	1.0	dB
Transmit/receive path isolation	ISOL	CW	27	33		dB
Input return loss	S11		15	17		dB
Output return loss	S22		10	15		dB
Quiescent current	I <sub>Q</sub>	No RF		85	110	mA
Operating current	I <sub>OP</sub>	P <sub>OUT</sub> = +29 dBm		650	720	mA
Leakage current	I <sub>LEAK</sub>	No RF input, module in standby mode		2		μA
Maximum VSWR for stable operation	VSWR <sub>MAX</sub>	CW	6:1	8:1		–

**Note 1:** Performance is guaranteed only under the conditions listed in this Table and is not guaranteed over the full operating or storage temperature ranges. Operation at elevated temperatures may reduce reliability of the device.

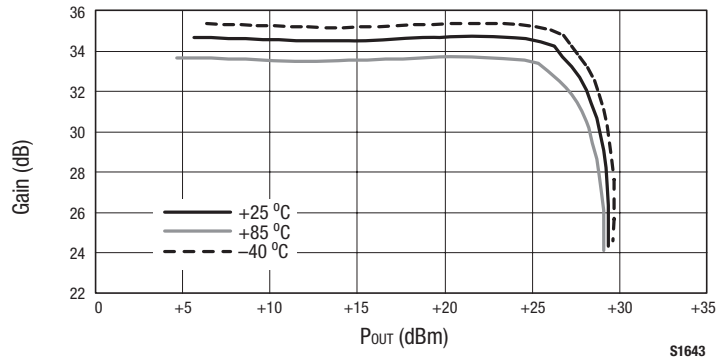

**Figure 3. Gain vs Output Power Over Temperature @ 460 MHz (Vcc = 3.6 V)**

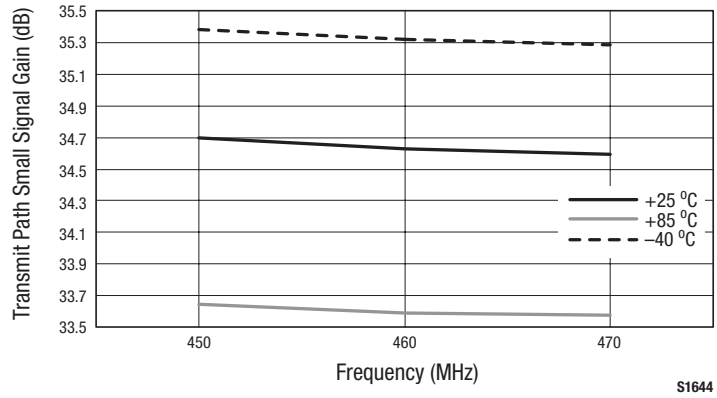

**Figure 4. Transmit Path Small Signal Gain vs Frequency Over Temperature (Vcc = 3.6 V)**

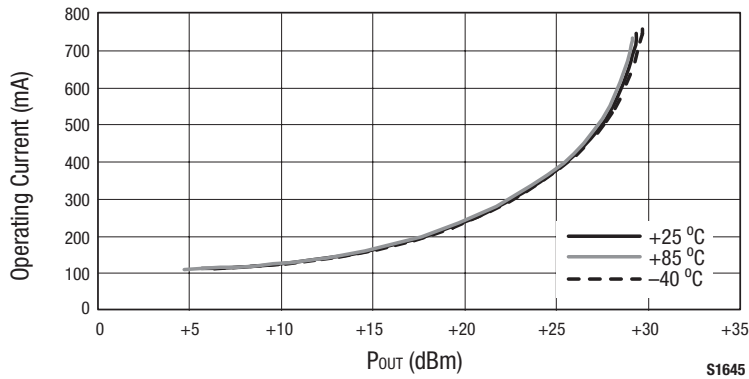

**Figure 5. Operating Current vs Output Power Over Temperature @ 460 MHz (Vcc = 3.6 V)**

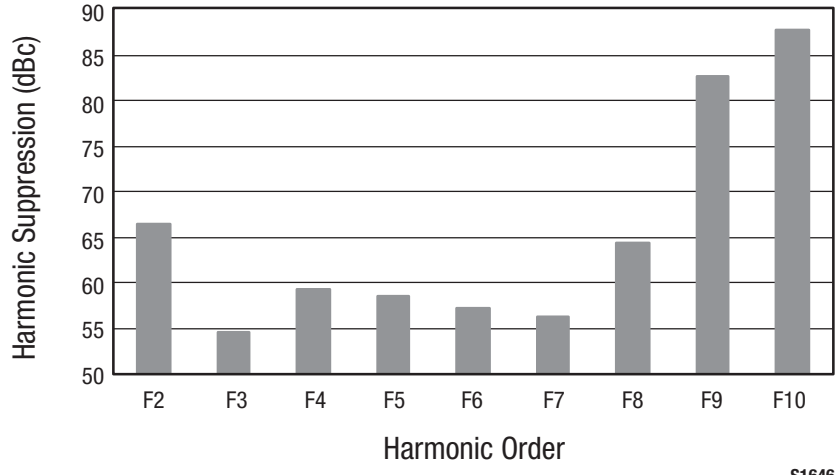

**Figure 6. Harmonics Level @ 460 MHz (Vcc = 3.6 V)**

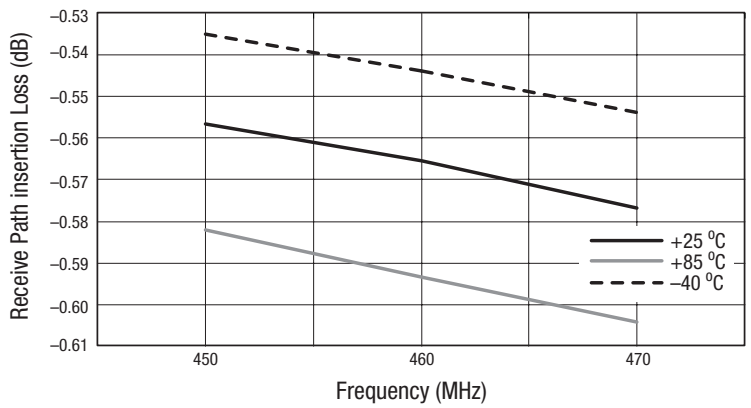

**Figure 7. Receive Path Insertion Loss vs Frequency Over Temperature (Vcc = 3.6 V)**

**Table 5. SKY65342-11 FEM Switch Control Logic**

Mode	V1 Signal (Pin 9)	V2 Signal (Pin 8)
Transmit	1	0
Receive	0	1

**Note:** Logic level 0: 0 V to 0.5 V  
Logic level 1: 2.0 V to Vcc

### Evaluation Board Description

The SKY65342-11 Evaluation Board is used to test the performance of the SKY65342-11 FEM. The Evaluation Board schematic diagram is shown in Figure 8. An assembly drawing for the Evaluation Board is shown in Figure 9 and the layer detail is provided in Figure 10. The layer detail physical characteristics are noted in Figure 11. Table 6 provides the Bill of Materials (BOM) list for Evaluation Board components.

### Circuit Design Considerations

The following design considerations are general in nature and must be followed regardless of final use or configuration:

1. Paths to ground should be made as short as possible.
2. The ground pad of the SKY65342-11 has special electrical and thermal grounding requirements. This pad is the main thermal conduit for heat dissipation. Since the circuit board acts as the heat sink, it must shunt as much heat as possible

from the device. Therefore, design the connection to the ground pad to dissipate the maximum wattage produced by the circuit board. Multiple vias to the grounding layer are required.

**NOTE:** A poor connection between the slug and ground increases junction temperature ( $T_J$ ), which reduces the lifetime of the device.

### Package Dimensions

The phone board layout footprint for the SKY65342-11 is shown in Figure 12. Package dimensions for the 12-pin MCM are shown in Figure 13, and tape and reel dimensions are provided in Figure 14.

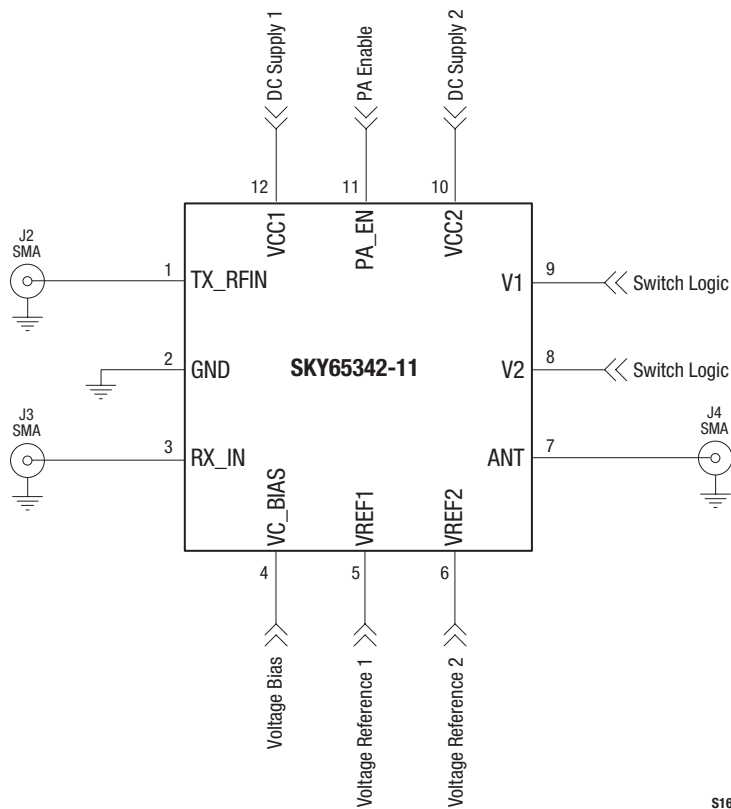
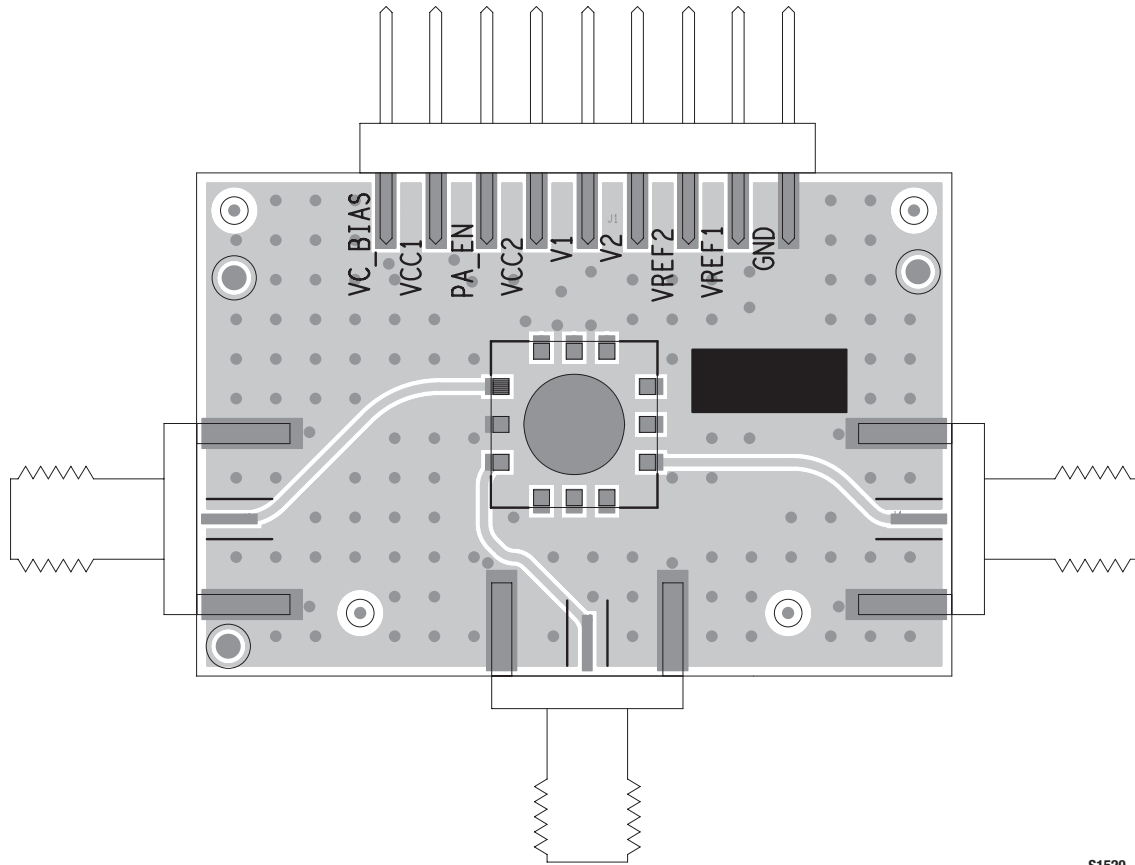

Figure 8. SKY65342-11 Evaluation Board Schematic



S1520

Figure 9. SKY65342-11 Evaluation Board Assembly Drawing



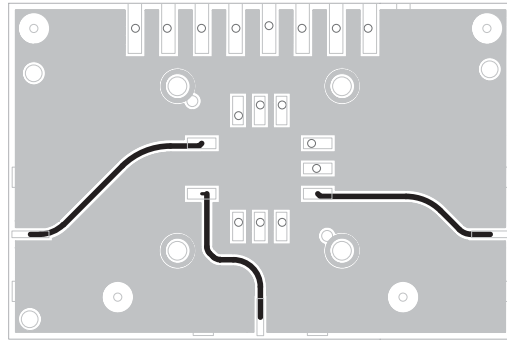

Layer 1: Top – Metal

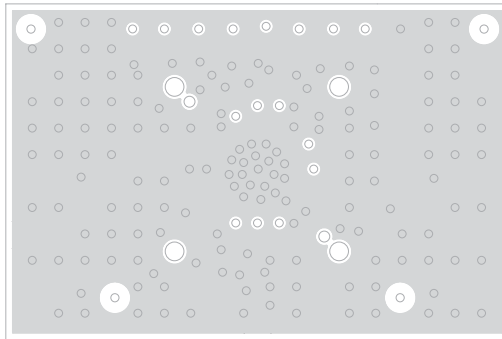

Layer 2: Ground

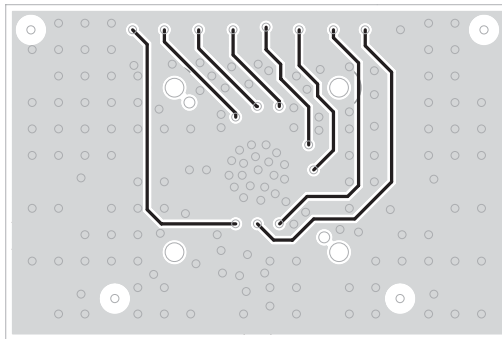

Layer 3: Power Plane

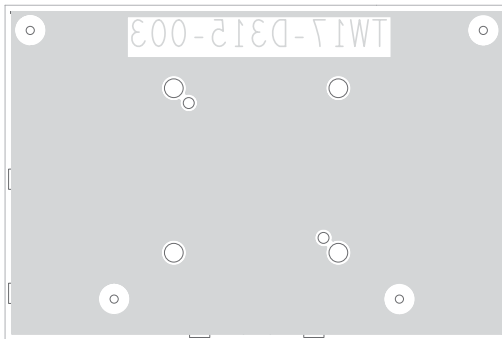

Layer 4: Solid Ground Plane

S1349

**Figure 10. SKY65342-11 Evaluation Board Layer Detail**

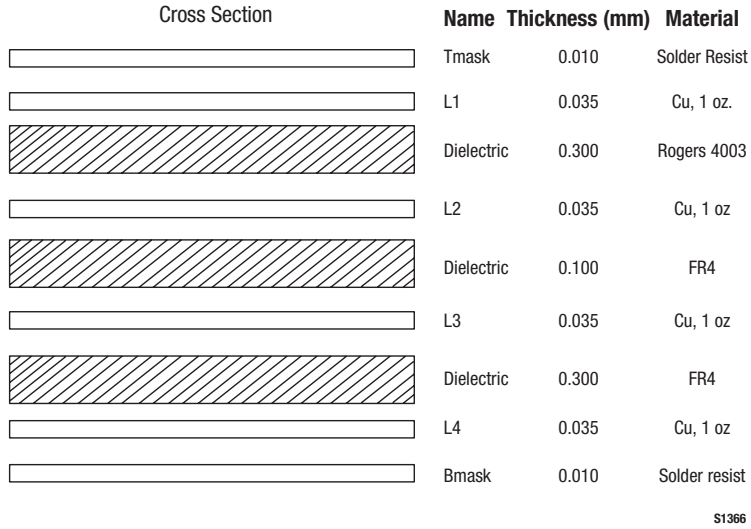
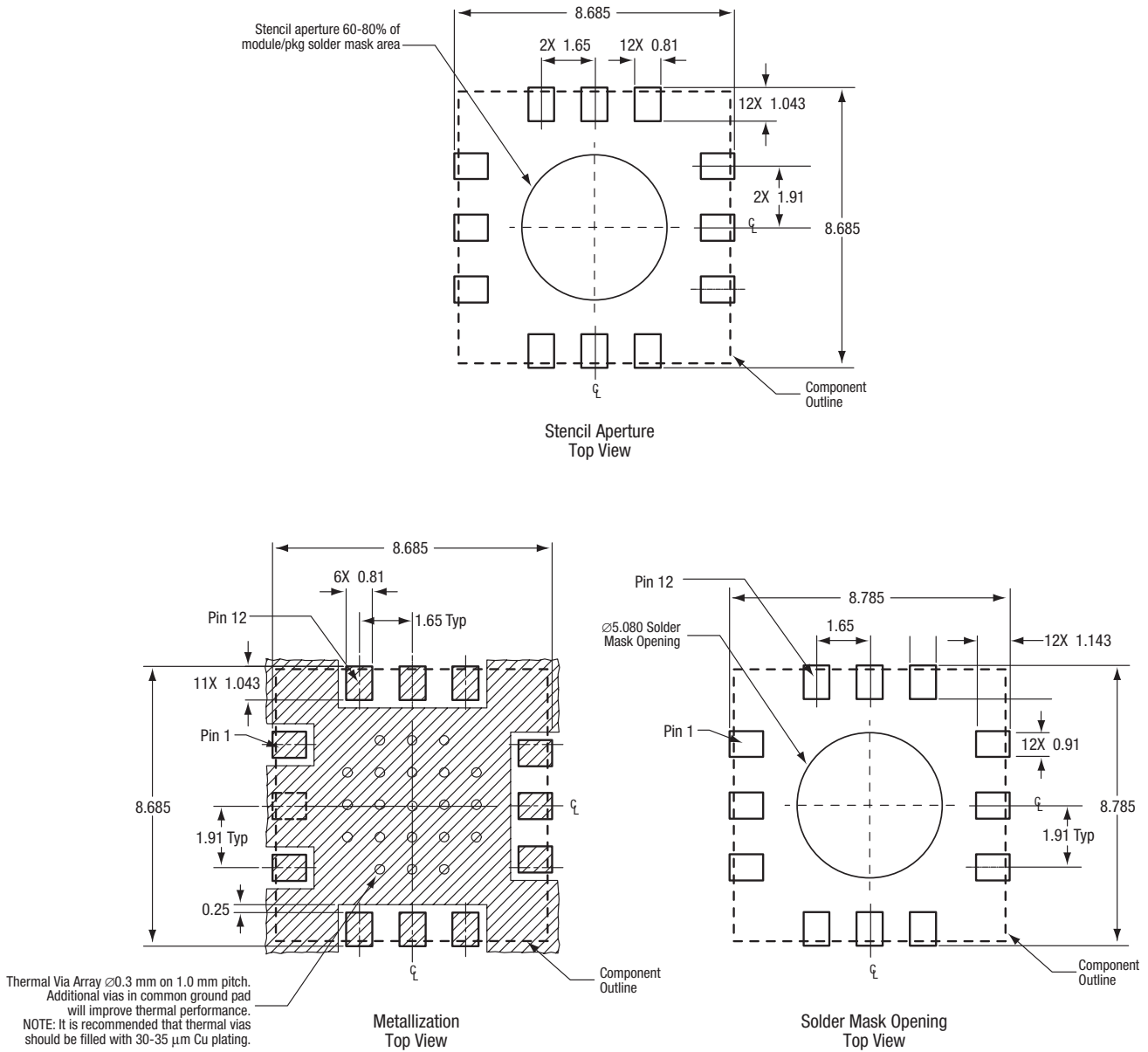

Figure 11. Layer Detail Physical Characteristics

Table 6. SKY65342-11 Evaluation Board Bill of Materials

Component	Quantity	Size	Value	Vendor	Part Number
J2, J3, J4	3				615R54-021
SC1, SC2, SC3, SC4	4				92196A052
Backframe	1				1056-101



All measurements are in millimeters

S1357

Figure 12. SKY65342-11 Phone Board Layout Footprint

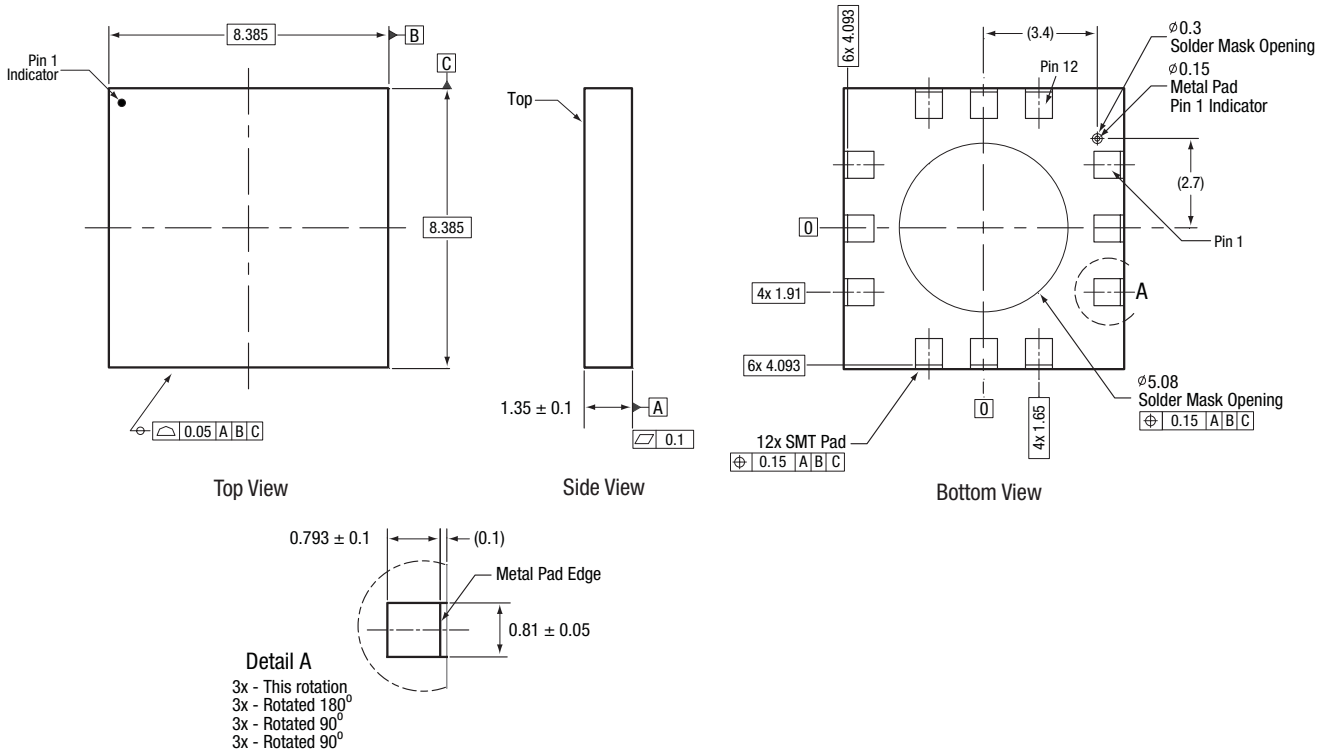

Dimensioning and tolerancing according to ASME Y14.5M-1994.  
 All measurements are in millimeters

S1354

Figure 13. SKY65342-11 12-Pin MCM Package Dimensions

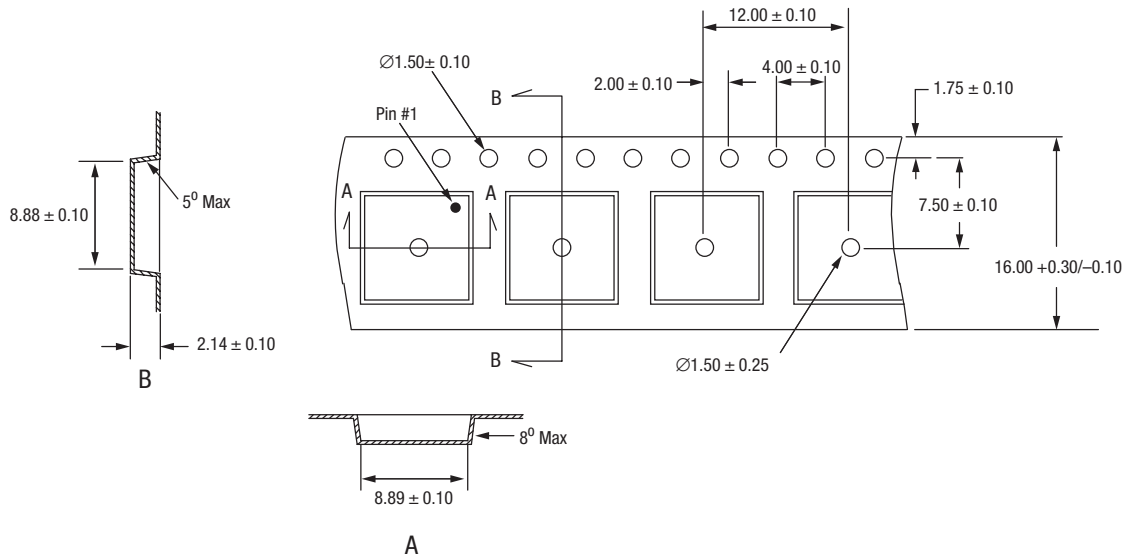

- Notes:
1. Carrier tape: black conductive poly carbonate or polystyrene.
  2. Cover tape material: transparent conductive PSA.
  3. Cover tape size: 13.3 mm width.
  4. All measurements are in millimeters.

S1252

Figure 14. SKY65342-11 Tape and Reel Dimensions

## Ordering Information

Model Name	Manufacturing Part Number	Evaluation Kit Part Number
SKY65342-11 450-470 MHz Front-End Module	SKY65342-11 (Pb-free package)	TW17-D315-003

Copyright © 2009 Skyworks Solutions, Inc. All Rights Reserved.

Information in this document is provided in connection with Skyworks Solutions, Inc. (“Skyworks”) products or services. These materials, including the information contained herein, are provided by Skyworks as a service to its customers and may be used for informational purposes only by the customer. Skyworks assumes no responsibility for errors or omissions in these materials or the information contained herein. Skyworks may change its documentation, products, services, specifications or product descriptions at any time, without notice. Skyworks makes no commitment to update the materials or information and shall have no responsibility whatsoever for conflicts, incompatibilities, or other difficulties arising from any future changes.

No license, whether express, implied, by estoppel or otherwise, is granted to any intellectual property rights by this document. Skyworks assumes no liability for any materials, products or information provided hereunder, including the sale, distribution, reproduction or use of Skyworks products, information or materials, except as may be provided in Skyworks Terms and Conditions of Sale.

THE MATERIALS, PRODUCTS AND INFORMATION ARE PROVIDED “AS IS” WITHOUT WARRANTY OF ANY KIND, WHETHER EXPRESS, IMPLIED, STATUTORY, OR OTHERWISE, INCLUDING FITNESS FOR A PARTICULAR PURPOSE OR USE, MERCHANTABILITY, PERFORMANCE, QUALITY OR NON-INFRINGEMENT OF ANY INTELLECTUAL PROPERTY RIGHT; ALL SUCH WARRANTIES ARE HEREBY EXPRESSLY DISCLAIMED. SKYWORKS DOES NOT WARRANT THE ACCURACY OR COMPLETENESS OF THE INFORMATION, TEXT, GRAPHICS OR OTHER ITEMS CONTAINED WITHIN THESE MATERIALS. SKYWORKS SHALL NOT BE LIABLE FOR ANY DAMAGES, INCLUDING BUT NOT LIMITED TO ANY SPECIAL, INDIRECT, INCIDENTAL, STATUTORY, OR CONSEQUENTIAL DAMAGES, INCLUDING WITHOUT LIMITATION, LOST REVENUES OR LOST PROFITS THAT MAY RESULT FROM THE USE OF THE MATERIALS OR INFORMATION, WHETHER OR NOT THE RECIPIENT OF MATERIALS HAS BEEN ADVISED OF THE POSSIBILITY OF SUCH DAMAGE.

Skyworks products are not intended for use in medical, lifesaving or life-sustaining applications, or other equipment in which the failure of the Skyworks products could lead to personal injury, death, physical or environmental damage. Skyworks customers using or selling Skyworks products for use in such applications do so at their own risk and agree to fully indemnify Skyworks for any damages resulting from such improper use or sale.

Customers are responsible for their products and applications using Skyworks products, which may deviate from published specifications as a result of design defects, errors, or operation of products outside of published parameters or design specifications. Customers should include design and operating safeguards to minimize these and other risks. Skyworks assumes no liability for applications assistance, customer product design, or damage to any equipment resulting from the use of Skyworks products outside of stated published specifications or parameters.

Skyworks, the Skyworks symbol, and “Breakthrough Simplicity” are trademarks or registered trademarks of Skyworks Solutions, Inc., in the United States and other countries. Third-party brands and names are for identification purposes only, and are the property of their respective owners. Additional information, including relevant terms and conditions, posted at [www.skyworksinc.com](http://www.skyworksinc.com), are incorporated by reference.

Компания «Life Electronics» занимается поставками электронных компонентов импортного и отечественного производства от производителей и со складов крупных дистрибьюторов Европы, Америки и Азии.

С конца 2013 года компания активно расширяет линейку поставок компонентов по направлению коаксиальный кабель, кварцевые генераторы и конденсаторы (керамические, пленочные, электролитические), за счёт заключения дистрибьюторских договоров

Мы предлагаем:

- Конкурентоспособные цены и скидки постоянным клиентам.
- Специальные условия для постоянных клиентов.
- Подбор аналогов.
- Поставку компонентов в любых объемах, удовлетворяющих вашим потребностям.
- Приемлемые сроки поставки, возможна ускоренная поставка.
- Доставку товара в любую точку России и стран СНГ.
- Комплексную поставку.
- Работу по проектам и поставку образцов.
- Формирование склада под заказчика.
- Сертификаты соответствия на поставляемую продукцию (по желанию клиента).
- Тестирование поставляемой продукции.
- Поставку компонентов, требующих военную и космическую приемку.
- Входной контроль качества.
- Наличие сертификата ISO.

В составе нашей компании организован Конструкторский отдел, призванный помогать разработчикам, и инженерам.

Конструкторский отдел помогает осуществить:

- Регистрацию проекта у производителя компонентов.
- Техническую поддержку проекта.
- Защиту от снятия компонента с производства.
- Оценку стоимости проекта по компонентам.
- Изготовление тестовой платы монтаж и пусконаладочные работы.



Тел: +7 (812) 336 43 04 (многоканальный)

Email: [org@lifeelectronics.ru](mailto:org@lifeelectronics.ru)