



3.3V CMOS 16-BIT REGISTERED TRANSCEIVER WITH 3-STATE OUTPUTS, 5 VOLT TOLERANT I/O, BUS-HOLD

IDT74LVCH16543A

FEATURES:

- Typical $t_{sk(o)}$ (Output Skew) < 250ps
- ESD > 2000V per MIL-STD-883, Method 3015; > 200V using machine model (C = 200pF, R = 0)
- $V_{cc} = 3.3V \pm 0.3V$, Normal Range
- $V_{cc} = 2.7V$ to $3.6V$, Extended Range
- CMOS power levels ($0.4\mu W$ typ. static)
- All inputs, outputs, and I/O are 5V tolerant
- Supports hot insertion
- Available in TSSOP package

DRIVE FEATURES:

- High Output Drivers: $\pm 24mA$
- Reduced system switching noise

APPLICATIONS:

- 5V and 3.3V mixed voltage systems
- Data communication and telecommunication systems

DESCRIPTION

The LVCH16543A 16-bit registered transceiver is built using advanced dual metal CMOS technology. The LVCH16543A can be used as two 8-bit transceivers or one 16-bit transceiver. Separate latch-enable (\overline{LEAB} or \overline{LEBA}) and output-enable (\overline{OEAB} or \overline{OEBA}) inputs are provided for each register to permit independent control in either direction of data flow. The A-to-B enable (\overline{CEAB}) input must be low in order to enter data from the A port or to output data from the B port. \overline{LEAB} controls the latch function. When \overline{LEAB} is low, the A to B latches are transparent. A subsequent low-to-high transition of \overline{LEAB} puts the A latches in the storage mode. \overline{OEAB} performs output enable function on the B port. Data flow from the B port to the A port is similar but requires using \overline{CEBA} , \overline{LEBA} , and \overline{OEBA} inputs. Flow-through organization of signal pins simplifies layout. All inputs are designed with hysteresis for improved noise margin.

All pins of this 16-bit registered transceiver can be driven from either 3.3V or 5V devices. This feature allows the use of this device as a translator in a mixed 3.3V/5V supply system.

The LVCH16543A has been designed with a $\pm 24mA$ output driver. This driver is capable of driving a moderate to heavy load while maintaining speed performance.

The LVCH16543A has "bus-hold" which retains the inputs' last state whenever the input goes to a high impedance. This prevents floating inputs and eliminates the need for pull-up/down resistors.

FUNCTIONAL BLOCK DIAGRAM

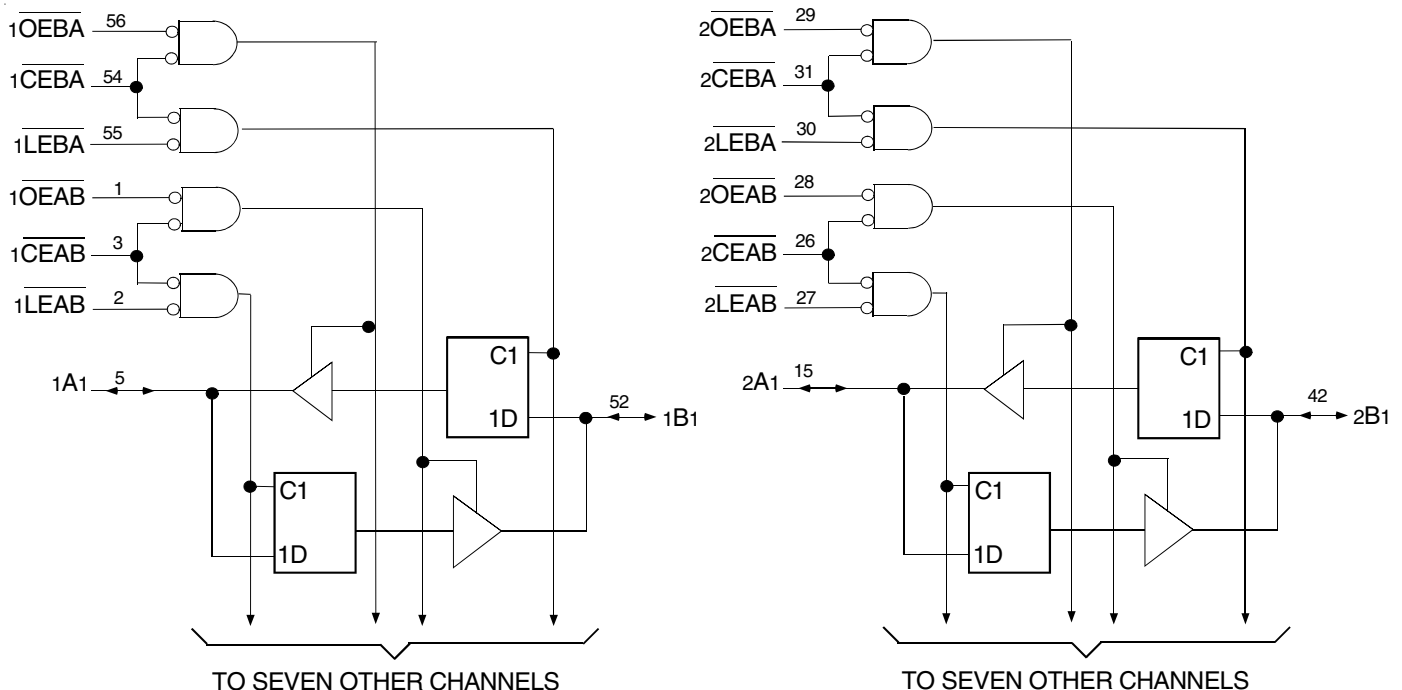

The IDT logo is a registered trademark of Integrated Device Technology, Inc.

INDUSTRIAL TEMPERATURE RANGE

JANUARY 2016

PIN CONFIGURATION

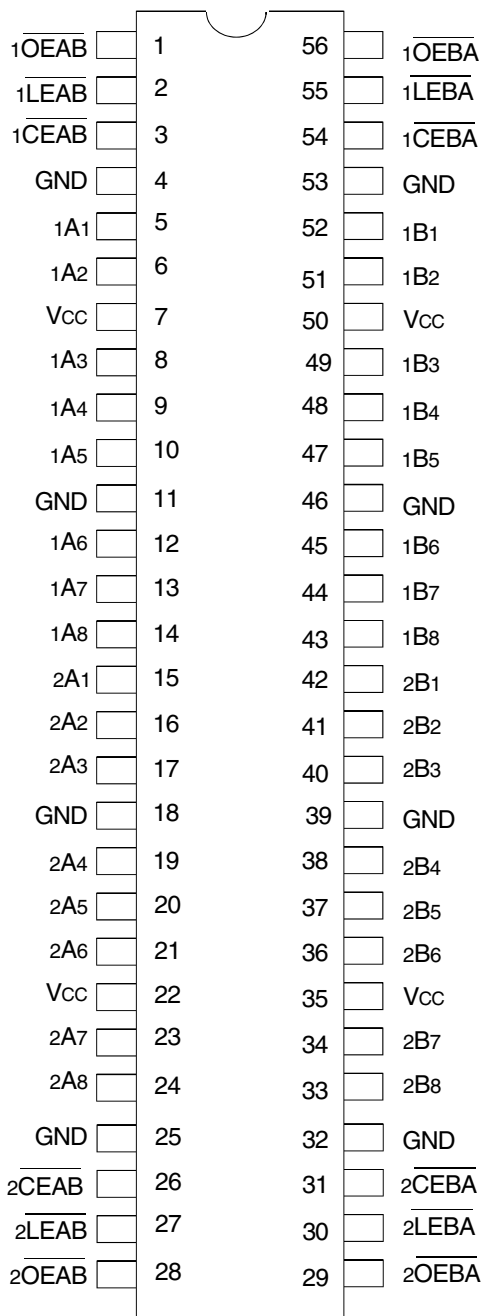

TSSOP
TOP VIEW

ABSOLUTE MAXIMUM RATINGS⁽¹⁾

Symbol	Description	Max	Unit
VTERM	Terminal Voltage with Respect to GND	-0.5 to +6.5	V
TSTG	Storage Temperature	-65 to +150	°C
IOUT	DC Output Current	-50 to +50	mA
I _{IK} I _{OK}	Continuous Clamp Current, V _I < 0 or V _O < 0	-50	mA
I _{CC} I _{SS}	Continuous Current through each V _{CC} or GND	±100	mA

NOTE:

- Stresses greater than those listed under ABSOLUTE MAXIMUM RATINGS may cause permanent damage to the device. This is a stress rating only and functional operation of the device at these or any other conditions above those indicated in the operational sections of this specification is not implied. Exposure to absolute maximum rating conditions for extended periods may affect reliability.

PIN DESCRIPTION

Pin Names	Description
x \overline{OEAB}	A-to-B Output Enable Input (Active LOW)
x \overline{OEBA}	B-to-A Output Enable Input (Active LOW)
x \overline{CEAB}	A-to-B Enable Input (Active LOW)
x \overline{CEBA}	B-to-A Enable Input (Active LOW)
x \overline{LEAB}	A-to-B Latch Enable Input (Active LOW)
x \overline{LEBA}	B-to-A Latch Enable Input (Active LOW)
xAx	A-to-B Data Inputs or B-to-A 3-State Outputs ⁽¹⁾
xBx	B-to-A Data Inputs or A-to-B 3-State Outputs ⁽¹⁾

NOTE:

- These pins have "Bus-Hold". All other pins are standard inputs, outputs, or I/Os.

FUNCTION TABLE (EACH 8-BIT SECTION)^(1,2)

Inputs			Latch Status	Output Buffers
x \overline{CEAB}	x \overline{LEAB}	x \overline{OEAB}	xAx to xBx	xBx
H	X	X	Storing	High Z
X	X	H	Storing	High Z
L	L	L	Transparent	Current A Inputs
L	H	L	Storing	Previous ⁽³⁾ A Inputs
L	L	H	Transparent	High Z
L	H	H	Storing	High Z
X	H	X	Storing	Not Recommended

NOTES:

- H = HIGH Voltage Level
L = LOW Voltage Level
X = Don't Care
Z = High-Impedance
- A-to-B data flow is shown. B-to-A data flow is similar but uses \overline{xCEBA} , \overline{xLEBA} , and \overline{xOEBA} .
- Before \overline{xLEAB} LOW-to-HIGH transition.

CAPACITANCE (T_A = +25°C, F = 1.0MHz)

Symbol	Parameter ⁽¹⁾	Conditions	Typ.	Max.	Unit
C _{IN}	Input Capacitance	V _{IN} = 0V	4.5	6	pF
C _{OUT}	Output Capacitance	V _{OUT} = 0V	6.5	8	pF
C _{I/O}	I/O Port Capacitance	V _{IN} = 0V	6.5	8	pF

NOTE:

- As applicable to the device type.

DC ELECTRICAL CHARACTERISTICS OVER OPERATING RANGE

Following Conditions Apply Unless Otherwise Specified:

Operating Condition: TA = -40°C to +85°C

Symbol	Parameter	Test Conditions		Min.	Typ. ⁽¹⁾	Max.	Unit
V _{IH}	Input HIGH Voltage Level	V _{CC} = 2.3V to 2.7V		1.7	—	—	V
		V _{CC} = 2.7V to 3.6V		2	—	—	
V _{IL}	Input LOW Voltage Level	V _{CC} = 2.3V to 2.7V		—	—	0.7	V
		V _{CC} = 2.7V to 3.6V		—	—	0.8	
I _{IH} I _{IL}	Input Leakage Current	V _{CC} = 3.6V	V _I = 0 to 5.5V	—	—	±5	μA
I _{OZH} I _{OZL}	High Impedance Output Current (3-State Output pins)	V _{CC} = 3.6V	V _O = 0 to 5.5V	—	—	±10	μA
I _{OFF}	Input/Output Power Off Leakage	V _{CC} = 0V, V _{IN} or V _O ≤ 5.5V		—	—	±50	μA
V _{IK}	Clamp Diode Voltage	V _{CC} = 2.3V, I _{IN} = -18mA		—	-0.7	-1.2	V
V _H	Input Hysteresis	V _{CC} = 3.3V		—	100	—	mV
I _{CC1} I _{CC2} I _{CC3}	Quiescent Power Supply Current	V _{CC} = 3.6V	V _{IN} = GND or V _{CC}	—	—	10	μA
			3.6 ≤ V _{IN} ≤ 5.5V ⁽²⁾	—	—	10	
ΔI _{CC}	Quiescent Power Supply Current Variation	One input at V _{CC} - 0.6V, other inputs at V _{CC} or GND		—	—	500	μA

NOTES:

1. Typical values are at V_{CC} = 3.3V, +25°C ambient.
2. This applies in the disabled state only.

BUS-HOLD CHARACTERISTICS

Symbol	Parameter ⁽¹⁾	Test Conditions		Min.	Typ. ⁽²⁾	Max.	Unit
I _{BH} I _{BHL}	Bus-Hold Input Sustain Current	V _{CC} = 3V	V _I = 2V	-75	—	—	μA
			V _I = 0.8V	75	—	—	
I _{BH} I _{BHL}	Bus-Hold Input Sustain Current	V _{CC} = 2.3V	V _I = 1.7V	—	—	—	μA
			V _I = 0.7V	—	—	—	
I _{BHO} I _{BHLO}	Bus-Hold Input Overdrive Current	V _{CC} = 3.6V	V _I = 0 to 3.6V	—	—	±500	μA

NOTES:

1. Pins with Bus-Hold are identified in the pin description.
2. Typical values are at V_{CC} = 3.3V, +25°C ambient.

OUTPUT DRIVE CHARACTERISTICS

Symbol	Parameter	Test Conditions ⁽¹⁾		Min.	Max.	Unit
VOH	Output HIGH Voltage	V _{CC} = 2.3V to 3.6V	I _{OH} = -0.1mA	V _{CC} -0.2	—	V
		V _{CC} = 2.3V	I _{OH} = -6mA	2	—	
		V _{CC} = 2.3V	I _{OH} = -12mA	1.7	—	
		V _{CC} = 2.7V		2.2	—	
		V _{CC} = 3V		2.4	—	
		V _{CC} = 3V	I _{OH} = -24mA	2	—	
VOL	Output LOW Voltage	V _{CC} = 2.3V to 3.6V	I _{OL} = 0.1mA	—	0.2	V
		V _{CC} = 2.3V	I _{OL} = 6mA	—	0.4	
			I _{OL} = 12mA	—	0.7	
		V _{CC} = 2.7V	I _{OL} = 12mA	—	0.4	
		V _{CC} = 3V	I _{OL} = 24mA	—	0.55	

NOTE:
1. V_{IH} and V_{IL} must be within the min. or max. range shown in the DC ELECTRICAL CHARACTERISTICS OVER OPERATING RANGE table for the appropriate V_{CC} range. T_A = -40°C to +85°C.

OPERATING CHARACTERISTICS, V_{CC} = 3.3V ± 0.3V, T_A = 25°C

Symbol	Parameter	Test Conditions	Typical	Unit
CPD	Power Dissipation Capacitance per Transceiver Outputs enabled	C _L = 0pF, f = 10Mhz	44	pF
CPD	Power Dissipation Capacitance per Transceiver Outputs disabled		4	

SWITCHING CHARACTERISTICS⁽¹⁾

Symbol	Parameter	V _{CC} = 2.7V		V _{CC} = 3.3V ± 0.3V		Unit
		Min.	Max.	Min.	Max.	
t _{PLH}	Propagation Delay, Transparent Mode	—	6.1	1.2	5.4	ns
t _{PHL}	xAx to xBx or xBx to xAx					
t _{PLH}	Propagation Delay	—	7.4	1.5	6.1	ns
t _{PHL}	xLEB _A to xAx, xLEAB to xBx					
t _{PZH}	Output Enable Time	—	7.9	1.2	6.6	ns
t _{PZL}	xCEB _A or xCEAB to xAx or xBx					
t _{PZH}	Output Enable Time	—	7.6	1	6.3	ns
t _{PZL}	xOEB _A or xOEB to xAx or xBx					
t _{PHZ}	Output Disable Time	—	7.1	1.5	6.6	ns
t _{PLZ}	xCEB _A or xCEAB to xAx or xBx					
t _{PHZ}	Output Disable Time	—	6.9	1.5	6.3	ns
t _{PLZ}	xOEB _A or xOEB to xAx or xBx					
t _{SU}	Set-up Time, data before CE _A ↑	1.1	—	1.1	—	ns
t _{SU}	Set-up Time, data before LE _A ↑, CE LOW	1.1	—	1.1	—	ns
t _H	Hold Time, data after CE _A ↑	1.9	—	1.9	—	ns
t _H	Hold Time, data after LE _A ↑, CE LOW	1.9	—	1.9	—	ns
t _w	Pulse Duration, xLEB _A or xLEAB, xCEB _A or xCEAB LOW	3.3	—	3.3	—	ns
t _{sk(o)}	Output Skew ⁽²⁾	—	—	—	500	ps

NOTES:
1. See TEST CIRCUITS AND WAVEFORMS. T_A = -40°C to +85°C.
2. Skew between any two outputs of the same package and switching in the same direction.

TEST CIRCUITS AND WAVEFORMS

TEST CONDITIONS

Symbol	V _{CC} ⁽¹⁾ =3.3V±0.3V	V _{CC} ⁽¹⁾ =2.7V	V _{CC} ⁽²⁾ =2.5V±0.2V	Unit
V _{LOAD}	6	6	2 x V _{CC}	V
V _{IH}	2.7	2.7	V _{CC}	V
V _T	1.5	1.5	V _{CC} / 2	V
V _{LZ}	300	300	150	mV
V _{HZ}	300	300	150	mV
C _L	50	50	30	pF

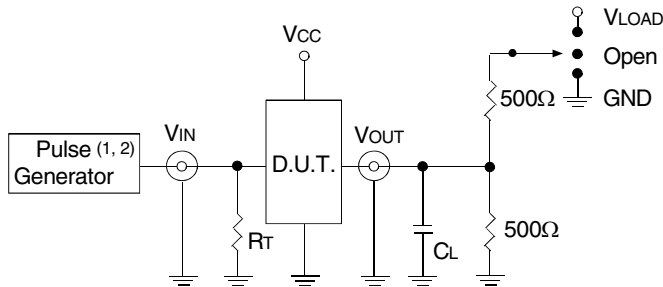

LVC Link

Test Circuit for All Outputs

DEFINITIONS:

C_L = Load capacitance: includes jig and probe capacitance.
R_T = Termination resistance: should be equal to Z_{OUT} of the Pulse Generator.

NOTES:

1. Pulse Generator for All Pulses: Rate ≤ 10MHz; t_r ≤ 2.5ns; t_r ≤ 2.5ns.
2. Pulse Generator for All Pulses: Rate ≤ 10MHz; t_r ≤ 2ns; t_r ≤ 2ns.

SWITCH POSITION

Test	Switch
Open Drain Disable Low Enable Low	V _{LOAD}
Disable High Enable High	GND
All Other Tests	Open

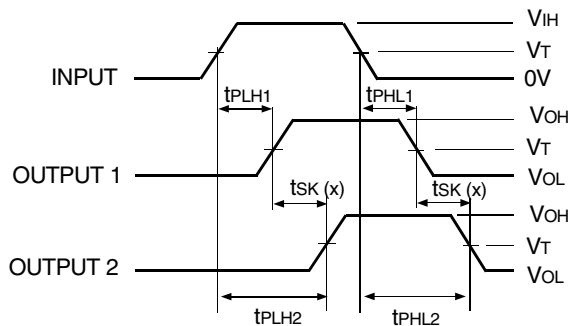

$$t_{SK}(x) = |t_{PLH2} - t_{PLH1}| \text{ or } |t_{PHL2} - t_{PHL1}|$$

LVC Link

Output Skew - t_{SK}(x)

NOTES:

1. For t_{SK}(o) OUTPUT1 and OUTPUT2 are any two outputs.
2. For t_{SK}(b) OUTPUT1 and OUTPUT2 are in the same bank.

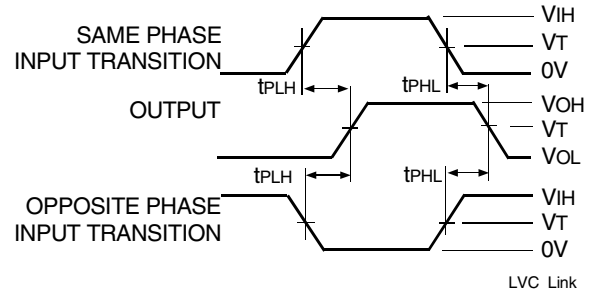

LVC Link

Propagation Delay

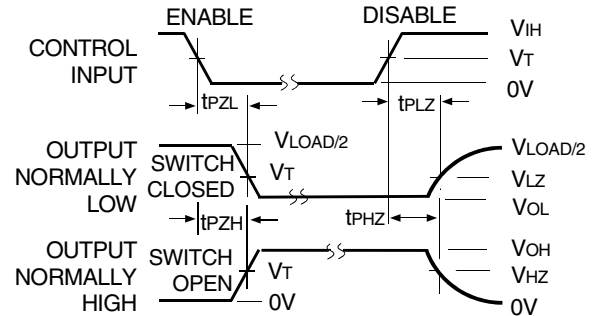

LVC Link

Enable and Disable Times

NOTE:

1. Diagram shown for input Control Enable-LOW and input Control Disable-HIGH.

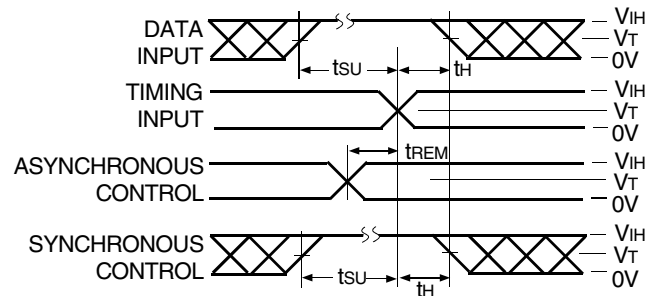

LVC Link

Set-up, Hold, and Release Times

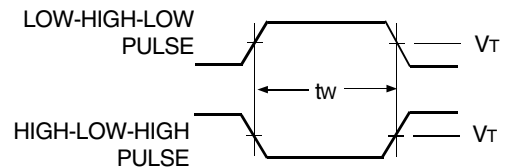

LVC Link

Pulse Width

ORDERING INFORMATION

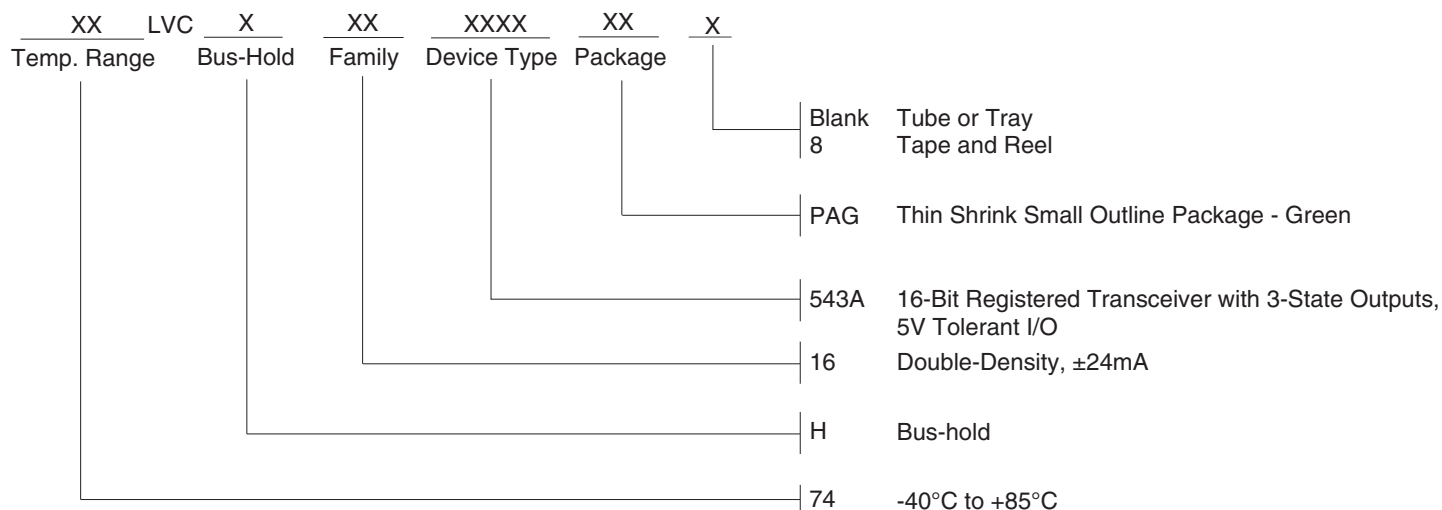

DATASHEET DOCUMENT HISTORY

01/21/2016 Pg. 6 Updated the ordering information by removing IDT notation and adding Tape and Reel information.



CORPORATE HEADQUARTERS
 6024 Silver Creek Valley Road
 San Jose, CA 95138

for SALES:
 800-345-7015 or 408-284-8200
 fax: 408-284-2775
 www.idt.com

for Tech Support:
 logichelp@idt.com

Компания «Life Electronics» занимается поставками электронных компонентов импортного и отечественного производства от производителей и со складов крупных дистрибьюторов Европы, Америки и Азии.

С конца 2013 года компания активно расширяет линейку поставок компонентов по направлению коаксиальный кабель, кварцевые генераторы и конденсаторы (керамические, пленочные, электролитические), за счёт заключения дистрибьюторских договоров

Мы предлагаем:

- Конкурентоспособные цены и скидки постоянным клиентам.
- Специальные условия для постоянных клиентов.
- Подбор аналогов.
- Поставку компонентов в любых объемах, удовлетворяющих вашим потребностям.
- Приемлемые сроки поставки, возможна ускоренная поставка.
- Доставку товара в любую точку России и стран СНГ.
- Комплексную поставку.
- Работу по проектам и поставку образцов.
- Формирование склада под заказчика.
- Сертификаты соответствия на поставляемую продукцию (по желанию клиента).
- Тестирование поставляемой продукции.
- Поставку компонентов, требующих военную и космическую приемку.
- Входной контроль качества.
- Наличие сертификата ISO.

В составе нашей компании организован Конструкторский отдел, призванный помогать разработчикам, и инженерам.

Конструкторский отдел помогает осуществить:

- Регистрацию проекта у производителя компонентов.
- Техническую поддержку проекта.
- Защиту от снятия компонента с производства.
- Оценку стоимости проекта по компонентам.
- Изготовление тестовой платы монтаж и пусконаладочные работы.



Тел: +7 (812) 336 43 04 (многоканальный)

Email: org@lifeelectronics.ru