

VSC8512

12-Port 10/100/1000BASE-T PHY with SGMII and QSGMII MAC Interface

Microsemi's next-generation triple-speed PHY delivers the industry's lowest power Gigabit Ethernet physical media solution.

The VSC8512 is the industry's first 12-port Gigabit Ethernet copper PHY solution in a single package. The VSC8512 leverages Microsemi's new 65 nm SimpliPHY™ technology, resulting in the one of the most cost-effective and lowest power consumption devices in the industry. The single chip solution includes the most advanced Ethernet energy efficiency features for bringing green technology solutions to market.

The VSC8512 employs the latest QSGMII MAC interface to reduce PCB routing to a MAC, switch, or ASIC chip. The VSC8512 is ideal for high-density switch and router applications, enabling Ethernet multiport systems to achieve very low system Bill of Material (BOM) costs, reducing overall production costs for more cost-effective deployments.

SimpliPHY devices use field-proven, fully adaptive equalization and innovative timing recovery algorithms for unparalleled noise tolerance performance. SimpliPHY devices are based on patented, fully balanced voltage-mode line driver technology, which allows lower cost magnetics to be used.

Highlights

- 12 GbE PHYs in a single package
- Four dual media copper/fiber ports
- Lowest BOM solution requires only two voltage planes

Applications

- Ethernet switches and routers
- Edge and Access platforms
- Blade servers

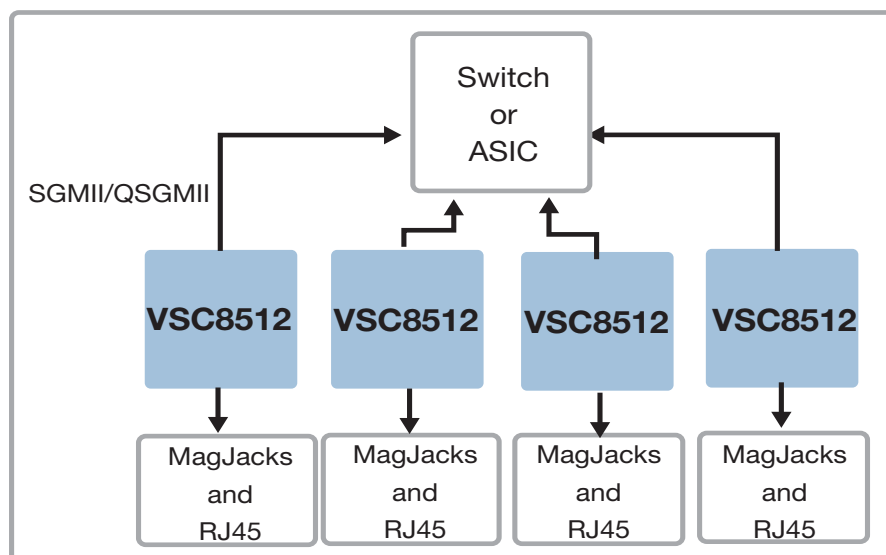

VSC8512

12-Port 10/100/1000BASE-T PHY with SGMII and QSGMII MAC Interface

Best-in-Class Power Consumption

- Lowest power GbE PHY in the industry, using Microsemi's 65 nm SimpliPHY™ technology
- Green energy efficiency modes including ActiPHY™, Perfect-Reach™, and Draft IEEE 802.3az
- Programmable direct drive LEDs with adjustable brightness levels
- Optimal power consumption for all link speeds

Features

- 12 integrated 10/100/1000BASE-T full and half duplex Ethernet transceivers with VeriPHY™ cable diagnostics
- SGMII and QSGMII SerDes MAC interfaces
- Four dual media copper/fiber ports with unidirectional IEEE 802.3ah support
- Patented line driver with low EMI voltage mode and integrated line side termination resistors
- Integrated quad I2C mux to control SFP and PoE modules
- Recovered clock outputs with programmable clock squelch control and fast link failure indication (<1 ms) for G.8261 SyncE applications
- Jumbo frame support up to 16 kB with programmable synchronization FIFOs
- Integrated AC-coupling capacitors on the MAC interface
- Extensive test features including loopbacks, packet generators, and CRC counters
- HP auto-MDIX support

Key Specifications

- 1.0 V core power supply
- 2.5 V I/O power supplies
- 3.3 V-tolerant 2.5 V inputs
- 27 mm × 27 mm ball grid array package
- Supports SGMII v1.9 and QSGMII v1.3, 1000BASE-X MACs, IEEE 1149.1 JTAG boundary scan, and IEEE 1149.6 AC-JTAG
- Compliant with IEEE 802.3 (10BASE-T, 10BASE-Te, 100BASE-TX, 1000BASE-T, 100BASE-FX, and 1000BASE-X)

Related Products

Visit www.microsemi.com for information about these related products:

- Ethernet switches and MACs
- 10G PHY solutions
- Electronic Dispersion Compensation CDRs



Microsemi Corporate Headquarters
One Enterprise, Aliso Viejo, CA 92656 USA
Within the USA: +1 (800) 713-4113
Outside the USA: +1 (949) 380-6100
Sales: +1 (949) 380-6136
Fax: +1 (949) 215-4996
email: sales.support@microsemi.com
www.microsemi.com

Microsemi Corporation (Nasdaq: MSCC) offers a comprehensive portfolio of semiconductor and system solutions for communications, defense and security, aerospace, and industrial markets. Products include high-performance and radiation-hardened analog mixed-signal integrated circuits, FPGAs, SoCs, and ASICs; power management products; timing and synchronization devices and precise time solutions; voice processing devices; RF solutions; discrete components; enterprise storage and communications solutions, security technologies, and scalable anti-tamper products; Ethernet solutions; Power-over-Ethernet ICs and midspans; custom design capabilities and services. Microsemi is headquartered in Aliso Viejo, California, and has approximately 4,800 employees worldwide. Learn more at www.microsemi.com.

Компания «Life Electronics» занимается поставками электронных компонентов импортного и отечественного производства от производителей и со складов крупных дистрибьюторов Европы, Америки и Азии.

С конца 2013 года компания активно расширяет линейку поставок компонентов по направлению коаксиальный кабель, кварцевые генераторы и конденсаторы (керамические, пленочные, электролитические), за счёт заключения дистрибьюторских договоров

Мы предлагаем:

- Конкурентоспособные цены и скидки постоянным клиентам.
- Специальные условия для постоянных клиентов.
- Подбор аналогов.
- Поставку компонентов в любых объемах, удовлетворяющих вашим потребностям.
- Приемлемые сроки поставки, возможна ускоренная поставка.
- Доставку товара в любую точку России и стран СНГ.
- Комплексную поставку.
- Работу по проектам и поставку образцов.
- Формирование склада под заказчика.
- Сертификаты соответствия на поставляемую продукцию (по желанию клиента).
- Тестирование поставляемой продукции.
- Поставку компонентов, требующих военную и космическую приемку.
- Входной контроль качества.
- Наличие сертификата ISO.

В составе нашей компании организован Конструкторский отдел, призванный помогать разработчикам, и инженерам.

Конструкторский отдел помогает осуществить:

- Регистрацию проекта у производителя компонентов.
- Техническую поддержку проекта.
- Защиту от снятия компонента с производства.
- Оценку стоимости проекта по компонентам.
- Изготовление тестовой платы монтаж и пусконаладочные работы.



Тел: +7 (812) 336 43 04 (многоканальный)

Email: org@lifeelectronics.ru