

RETRACTOR MODEL		ITEM 3		ITEM 4		ITEM 6			ITEM 23		RETRACTOR OUTER COLOR
MATERIAL NUMBER	ENGINEERING NUMBER	MATERIAL NUMBER	ENGINEERING NUMBER	MATERIAL NUMBER	ENGINEERING NUMBER	MATERIAL NUMBER	ENGINEERING NUMBER	COLOR	MATERIAL NUMBER	ENGINEERING NUMBER	
1301750062	10FLS	1301790124	9699-203	1301790121	9678-8-#1	1301790913	AG17260	PLAIN	1302344666	13613	BLUE
1301750057	10FLS-EU	1301790124	9699-203	1301792109	BG17895	1301790913	AG17260	PLAIN	N/A	N/A	BLUE
1301750063	22FLS	1301790125	9699-245	1301790121	9678-8-#1	1301792171	AG17270	BLACK	1302344666	13613	BLUE
1301750058	22FLS-EU	1301790125	9699-245	1301792109	BG17895	1301792171	AG17270	BLACK	N/A	N/A	BLUE

**LOAD CAPACITY CHART:**

RETRACTOR MODEL:	EACH RETRACT IS 100% TESTED UNDER THIS WEIGHT:	
	IN LBS:	IN KGS:
10FLS / 10FLS-EU	10	4.5
22FLS / 22FLS-EU	22	10

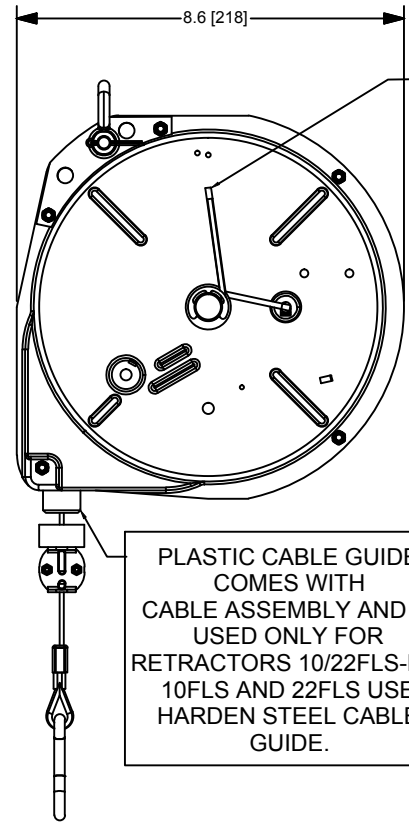
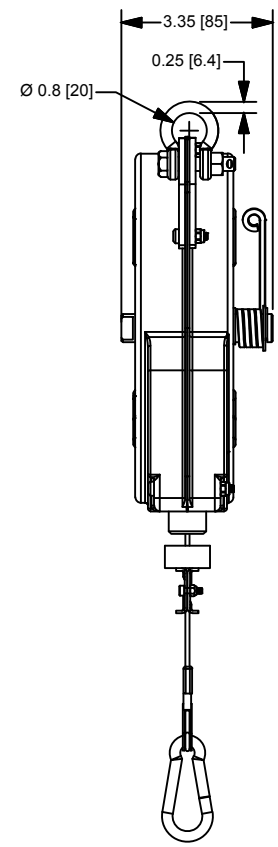
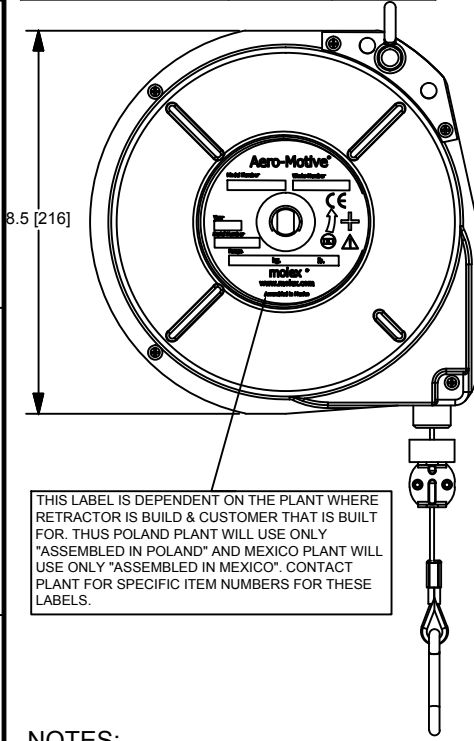

PLASTIC CABLE GUIDE COMES WITH CABLE ASSEMBLY AND IS USED ONLY FOR RETRACTORS 10/22FLS-EU. 10FLS AND 22FLS USE HARDEN STEEL CABLE GUIDE.

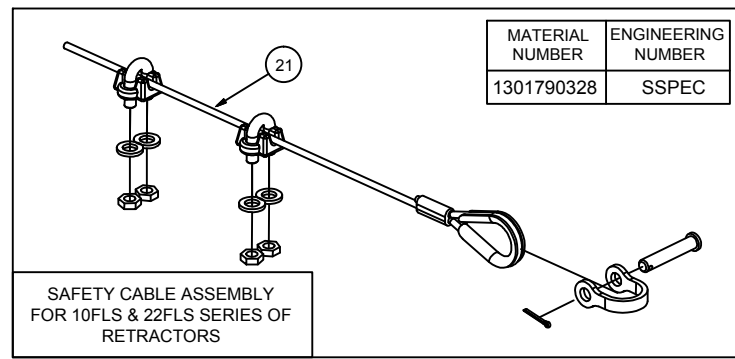

**SAFETY MECHANISM COMPONENTS**

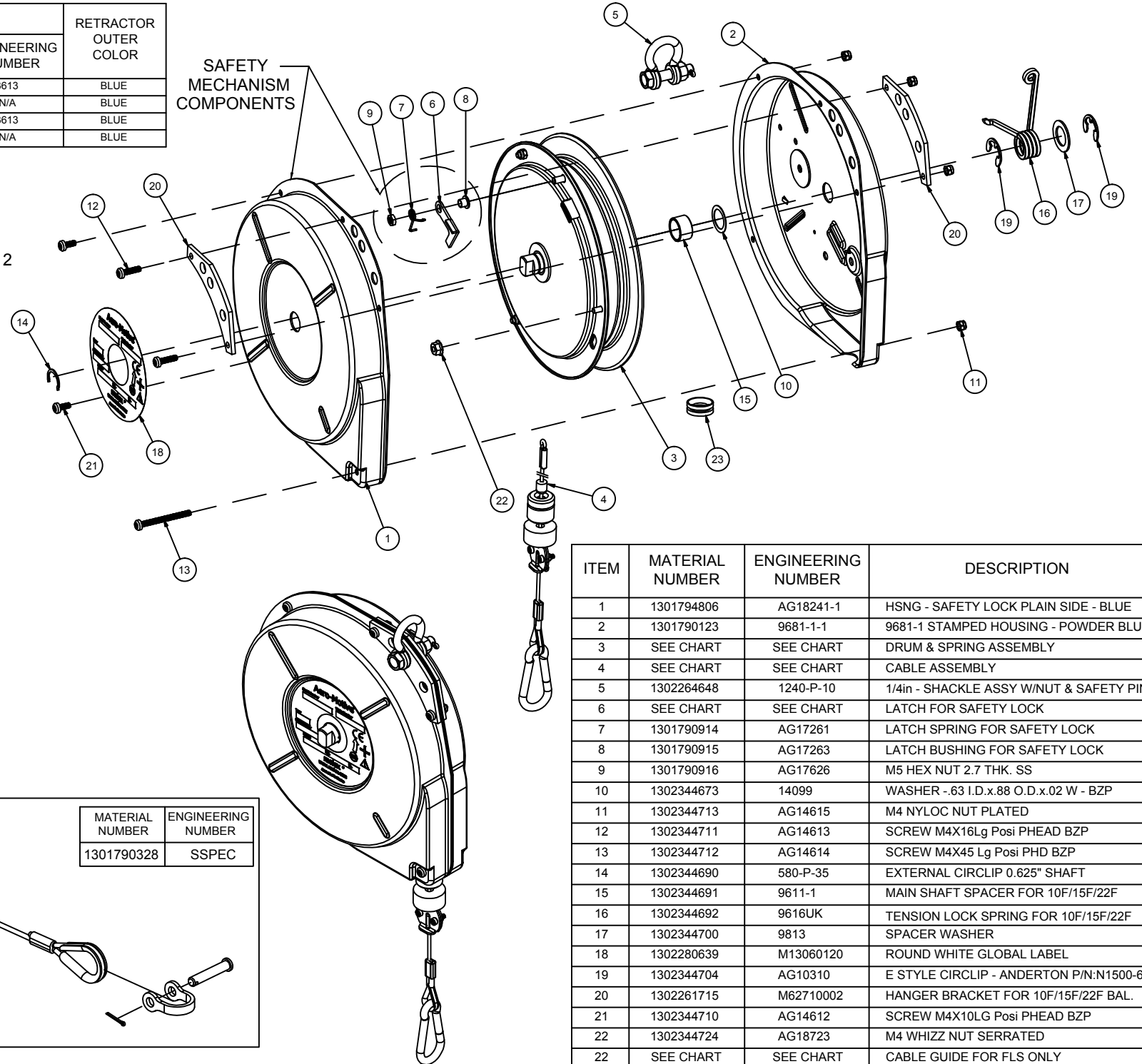

ITEM	MATERIAL NUMBER	ENGINEERING NUMBER	DESCRIPTION
1	1301794806	AG18241-1	HSNG - SAFETY LOCK PLAIN SIDE - BLUE
2	1301790123	9681-1-1	9681-1 STAMPED HOUSING - POWDER BLUE
3	SEE CHART	SEE CHART	DRUM & SPRING ASSEMBLY
4	SEE CHART	SEE CHART	CABLE ASSEMBLY
5	1302264648	1240-P-10	1/4in - SHACKLE ASSY W/NUT & SAFETY PIN
6	SEE CHART	SEE CHART	LATCH FOR SAFETY LOCK
7	1301790914	AG17261	LATCH SPRING FOR SAFETY LOCK
8	1301790915	AG17263	LATCH BUSHING FOR SAFETY LOCK
9	1301790916	AG17626	M5 HEX NUT 2.7 THK. SS
10	1302344673	14099	WASHER -.63 I.D.x.88 O.D.x.02 W - BZP
11	1302344713	AG14615	M4 NYLOC NUT PLATED
12	1302344711	AG14613	SCREW M4X16Lg Posi PHEAD BZP
13	1302344712	AG14614	SCREW M4X45 Lg Posi PHD BZP
14	1302344690	580-P-35	EXTERNAL CIRCLIP 0.625" SHAFT
15	1302344691	9611-1	MAIN SHAFT SPACER FOR 10F/15F/22F
16	1302344692	9616UK	TENSION LOCK SPRING FOR 10F/15F/22F
17	1302344700	9813	SPACER WASHER
18	1302280639	M13060120	ROUND WHITE GLOBAL LABEL
19	1302344704	AG10310	E STYLE CIRCLIP - ANDERTON P/N:N1500-62
20	1302261715	M62710002	HANGER BRACKET FOR 10F/15F/22F BAL.
21	1302344710	AG14612	SCREW M4X10Lg Posi PHEAD BZP
22	1302344724	AG18723	M4 WHIZZ NUT SERRATED
23	SEE CHART	SEE CHART	CABLE GUIDE FOR FLS ONLY

- NOTES:**
- XXFLS SERIES OF RETRACTORS IS THE SAME AS STANDARD F SERIES WITH EXCEPTION THAT XXFLS SERIES IS EQUIPPED WITH SAFETY MECHANISM (ITEM 1, 6, 7, 8 & 9) THAT IN CASE OF SPRING FAILURE ENGAGES AND STOP FALLING CABLE.
  - SAFETY MECHANISM WORKS IN THE WAY THAT WHEN POWER SPRING IS TENSIONED, THE COILS PULL INWARDS ALLOWING THE SPRING LOADED SAFETY LATCH TO MOVE TO THE CENTER OF THE DRUM. IF THE POWER SPRING BREAKS OR TENSION IS SUDDENLY RELEASED FROM SPRING, THE SAFETY LATCH IS PUNCH BY POWER SPRING AND IT ENGAGES WITH ONE OF THE 12 STOPS ON THE INSIDE OF THE TOP HOUSING (ITEM 1).
  - DO NOT SUDDENLY RELEASE TENSION FROM RETRACTOR. SUDDENLY RELEASED TENSION FROM TENSION SPRING WILL CAUSE SAFETY MECHANISM TO ENGAGE AND WILL CAUSE SPRING LOSE OF PROPERTIES. ALWAYS REFER TO SAFETY MANUALS.
  - RETRACTORS ARE TO BE 100% INSPECTED & PRE-TENSIONED AT FACTORY. TEST RETRACTORS WITH ASSIGNED WEIGHT SUCH THAT LOAD IS NOT DROPPED BUT IT IS FULLY RETRACTED OVER THE FULL CABLE TRAVEL.
  - STEEL HOUSINGS HAVE A POWDER COATED FINISH TO MEET HARSH INDUSTRIAL ENVIRONMENTS.
  - ALWAYS READ INSTRUCTIONS MANUAL BEFORE USING RETRACTORS.
  - RETRACTORS ARE NOT TO BE USED AS BALANCERS THEIR MAIN PURPOSE BEING TO RETRACT A LOAD AND NOT TO BALANCE ONE.
  - STANDARD RETRACTORS DO NOT COME EQUIPPED WITH A SAFETY CHAIN. IF APPLICATION REQUIRES A SAFETY CHAIN ADD "SC" SUFFIX TO STANDARD PART NUMBER. EXAMPLE 22FLSSC.
  - WHEN MOUNTING RETRACTOR, ALWAYS MAKE SURE THAT SAFETY PIN WHICH COMES WITH SHACKLE IS INSTALLED & SECURED.

RELEASE TO GSM EC NO: IPG2013-0637 DRWN: MCHOJECK 2013/03/25 CHKD: JM APPR: JFMURPHY 2013/12/26	DESCRIPTION REV	QUALITY SYMBOLS ▽=0 ◁=0	GENERAL TOLERANCES (UNLESS SPECIFIED)		DIMENSION STYLE INCH / MM		SCALE NTS	DESIGN UNITS INCH	THIRD ANGLE PROJECTION					
			4 PLACES ±--- ±--- 3 PLACES ±--- ±--- 2 PLACES ±--- ±--- 1 PLACE ±--- ±---	ANGULAR ±.5°		DRAFT WHERE APPLICABLE MUST REMAIN WITHIN DIMENSIONS		SEE TABLE		THIS DRAWING CONTAINS INFORMATION THAT IS PROPRIETARY TO MOLEX INCORPORATED AND SHOULD NOT BE USED WITHOUT WRITTEN PERMISSION				
			DRAWN BY DATE MCHOJECK 2013/03/25		CHECKED BY DATE JM 2013/03/25		APPROVED BY DATE JFMURPHY 2013/12/26		TITLE <b>F SERIES OF RETRACTORS WITH SAFETY MECHANISM</b>		MOLEX INCORPORATED			
			MATERIAL NO.		DOCUMENT NO. <b>SD-130175-005</b>		SHEET NO. <b>1 OF 1</b>							

Компания «Life Electronics» занимается поставками электронных компонентов импортного и отечественного производства от производителей и со складов крупных дистрибьюторов Европы, Америки и Азии.

С конца 2013 года компания активно расширяет линейку поставок компонентов по направлению коаксиальный кабель, кварцевые генераторы и конденсаторы (керамические, пленочные, электролитические), за счёт заключения дистрибьюторских договоров

Мы предлагаем:

- Конкурентоспособные цены и скидки постоянным клиентам.
- Специальные условия для постоянных клиентов.
- Подбор аналогов.
- Поставку компонентов в любых объемах, удовлетворяющих вашим потребностям.
- Приемлемые сроки поставки, возможна ускоренная поставка.
- Доставку товара в любую точку России и стран СНГ.
- Комплексную поставку.
- Работу по проектам и поставку образцов.
- Формирование склада под заказчика.
- Сертификаты соответствия на поставляемую продукцию (по желанию клиента).
- Тестирование поставляемой продукции.
- Поставку компонентов, требующих военную и космическую приемку.
- Входной контроль качества.
- Наличие сертификата ISO.

В составе нашей компании организован Конструкторский отдел, призванный помогать разработчикам, и инженерам.

Конструкторский отдел помогает осуществить:

- Регистрацию проекта у производителя компонентов.
- Техническую поддержку проекта.
- Защиту от снятия компонента с производства.
- Оценку стоимости проекта по компонентам.
- Изготовление тестовой платы монтаж и пусконаладочные работы.



Тел: +7 (812) 336 43 04 (многоканальный)

Email: [org@lifeelectronics.ru](mailto:org@lifeelectronics.ru)