

Distinctive Characteristics

Brilliant illumination for highly visible status indication with LEDs and caps in red, green, or amber; subdued illumination for low light requirements with white cap over red, green, or amber LEDs.

Photo interrupter, rather than contacts, ensures high reliability and long life of 3 million operations minimum.

Rugged construction and smooth actuation allow repeated, rapid actuation force anywhere on cap surface.

Snap-in mounting for easy installation.

Connector socket with 6 pins for simple connection.

Well suited for gaming and vending machines, as well as equipment exposed to corrosive gases used in environments such as chemical or steel manufacturing plants.

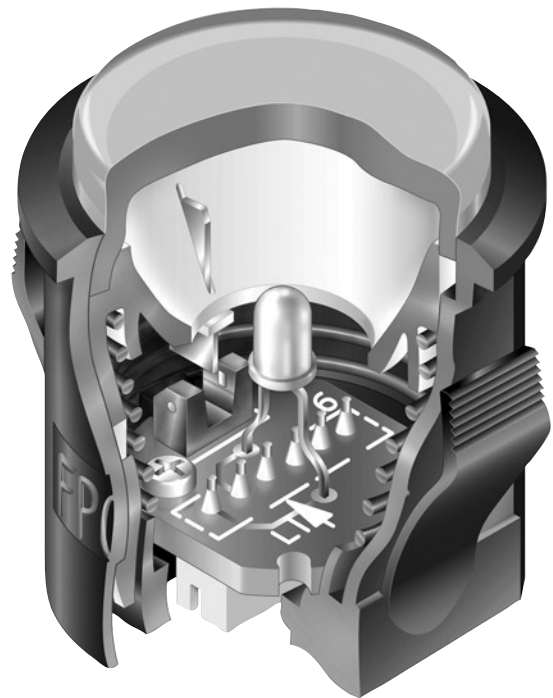

Actual Size

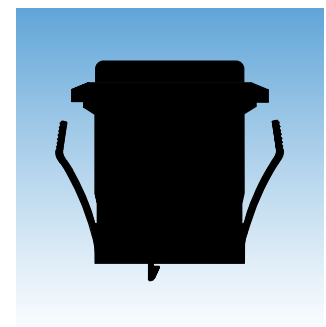

TYPICAL SWITCH ORDERING EXAMPLE

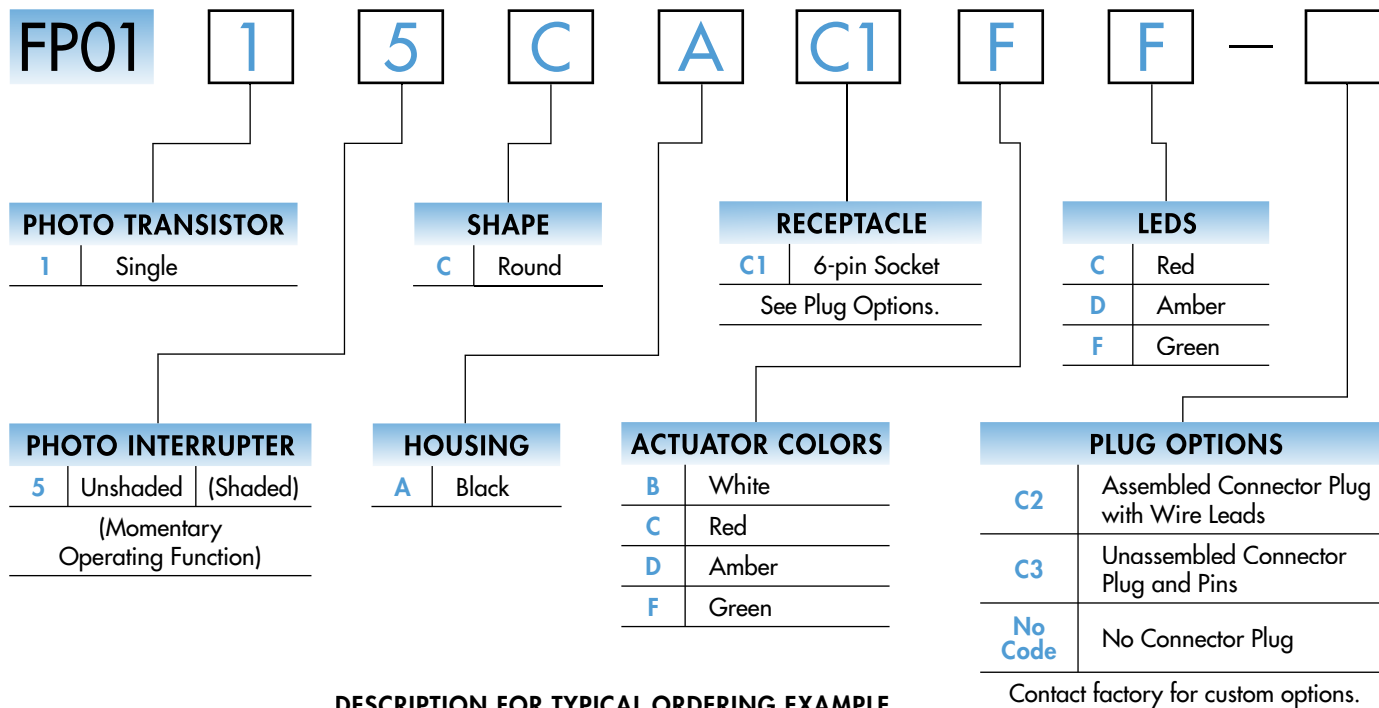

DESCRIPTION FOR TYPICAL ORDERING EXAMPLE

FP0115CAC1FF



ACTUATOR & INTERRUPTER

		Actuator Position		Photo Interrupter		Schematics
Model	1	Normal	Down	Unshaded	Shaded	LED connector pins are 5 & 6; interrupter connector pins are 3-4 & 1-2.
				5	Normally Unshaded with Momentary Shaded status	
FP0115	Single Photo Transistor	When shaded, the photo transistor momentarily activates electrical function which signals the external device to change its state.				

HOUSING SHAPE & COLOR

C Round Shape **A** Black Housing

INTERNAL RECEPTACLE

C1 Receptacle
Internal male connector socket

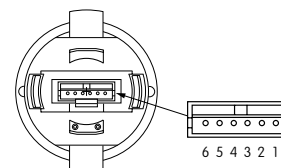

SWITCH SPECIFICATIONS

	Actuator Up	Actuator Down
Status of Photo Interrupter:	Unshaded	Shaded
Collector Current I_C :	0.8mA minimum	10 μ A maximum
Status of Photo Transistor:	On	Off
Output Condition of Photo Transistor:	$I_F = 20\text{mA}$ & $V_{CE} = 5\text{V}$	

MECHANICAL SPECIFICATIONS

Total Travel:	.079" (2.0mm)
Operating Force:	0.75 N (.169 lbf)
Mechanical Life:	3,000,000 operations minimum
Operating Temperature Range:	-25°C through +50°C (-13°F through +122°F)

MATERIALS

Actuator:	Polyacetal
Housing:	Polyamide

PHOTO INTERRUPTER SPECIFICATIONS

(Temperature @ 25°C)

Electrical & Optical Characteristics	Typical	Maximum	Condition
Input			
Forward Voltage V_F :	1.3V	1.6V	$I_F = 50\text{mA}$
Reverse Current I_R :		10 μ A	$F_R = 5\text{V}$
Transmission			
Collector-Emitter Saturation Voltage $V_{CE\ sat}$:		0.4V	$I_F = 20\text{mA}$ & $I_C = 0.1\text{mA}$
Absolute Maximum Ratings			
Input LED		Output Photo Transistor	
Forward Current I_F :	50mA	Collector-Emitter Voltage V_{CEO} :	30V
Reverse Voltage V_R :	5V	Emitter-Collector Voltage V_{ECO} :	4.5V
Power Dissipation P_D :	80mW	Collector Current I_C :	30mA
		Collector Dissipation P_C :	80mW

Circuit Design Considerations

Output of the infrared LED in the photo interrupter decreases approximately 50% after 100,000 hours.

Recommended load resistance (R_L) is 40k ~ 120k Ω for the illustrated circuit.

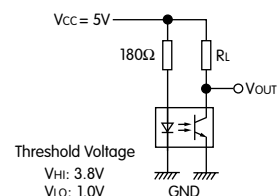

EXTERNAL PLUG OPTIONS

C2 **AT021**
Assembled Connector Plug
with Wire Leads

Connector plug body: JST model ZHR-6
Crimp connector pins: JST model SZH-002T-P0.5
Wire leads: 28-26AWG; 12-inch, unstripped;
Blue for Pin 1

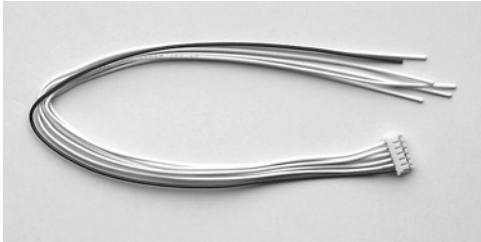

C2 **AT022**
Unassembled Connector Plug
and Pins

1 connector plug and 8 crimp connector
pins only (no wire leads provided).

Matching wire leads: 28-26AWG

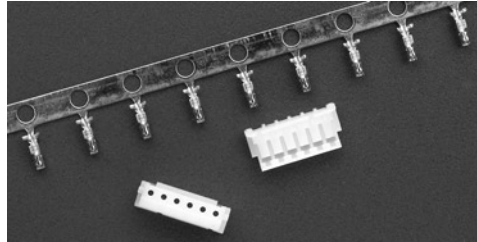

No Code

No Connector Plug

Recommended connector
plug for assembly:
JST model number ZHR-6

Recommended crimp
connector pins:
JST model SZH-002T-P0.5
for 28-26AWG wire leads
or SZH-003T-P0.5 for
32-28AWG wire leads.

ACTUATOR COLORS

B White

C Red

D Amber

F Green

LED COLORS & SPECIFICATIONS

LEDs are an integral part of the switch and not available separately. The electrical specifications shown are determined at a basic temperature of 25°C.

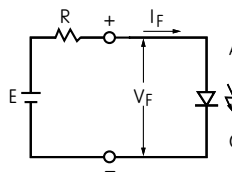

$$R = \frac{E - V_F}{I_F}$$

If the source voltage exceeds the rated voltage, a ballast resistor is required.

Where: R = Resistor Value (Ohms)
E = Source Voltage (V)
V_F = Forward Voltage (V)
I_F = Forward Current (A)

Single Element LED		C	D	F
	Color	Red	Amber	Green
Forward Peak Current	I _{FM}	30mA	25mA	25mA
Continuous Forward Current	I _F	20mA	20mA	20mA
Forward Voltage	V _F	1.85V	2.0V	2.25V
Reverse Peak Voltage	V _{RM}	5V	5V	5V
Current Reduction Rate Above 25°C	ΔI _F	0.38mA /°C	0.28mA /°C	0.40mA /°C
Ambient Temperature Range		-25° ~ +50°C		

TYPICAL SWITCH DIMENSIONS

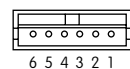
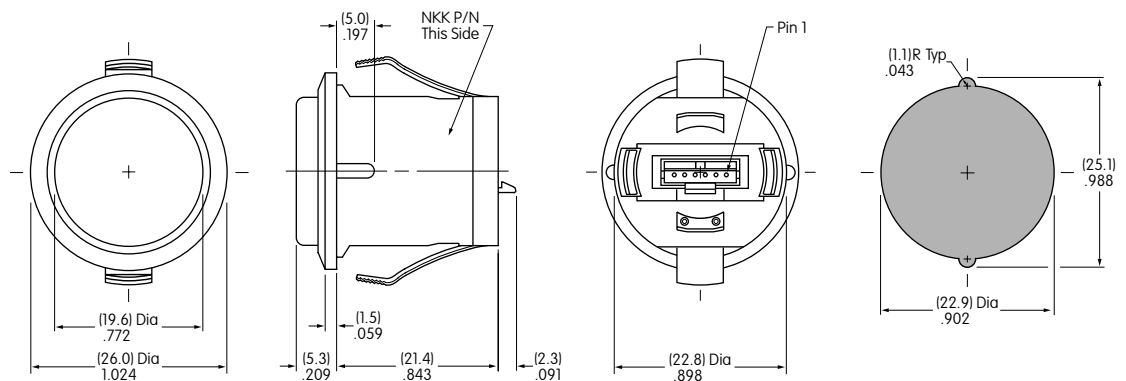

Terminal Connector Detail

Recommended Panel
Thickness Range:
.098" ~ .197"
(2.5mm ~ 5.0mm)

FP0115CAC1FF

Mouser Electronics

Authorized Distributor

Click to View Pricing, Inventory, Delivery & Lifecycle Information:

[NKK Switches:](#)

[AT021](#) [AT022](#) [AT021X001](#)

Компания «Life Electronics» занимается поставками электронных компонентов импортного и отечественного производства от производителей и со складов крупных дистрибьюторов Европы, Америки и Азии.

С конца 2013 года компания активно расширяет линейку поставок компонентов по направлению коаксиальный кабель, кварцевые генераторы и конденсаторы (керамические, пленочные, электролитические), за счёт заключения дистрибьюторских договоров

Мы предлагаем:

- Конкуренспособные цены и скидки постоянным клиентам.
- Специальные условия для постоянных клиентов.
- Подбор аналогов.
- Поставку компонентов в любых объемах, удовлетворяющих вашим потребностям.
- Приемлемые сроки поставки, возможна ускоренная поставка.
- Доставку товара в любую точку России и стран СНГ.
- Комплексную поставку.
- Работу по проектам и поставку образцов.
- Формирование склада под заказчика.
- Сертификаты соответствия на поставляемую продукцию (по желанию клиента).
- Тестирование поставляемой продукции.
- Поставку компонентов, требующих военную и космическую приемку.
- Входной контроль качества.
- Наличие сертификата ISO.

В составе нашей компании организован Конструкторский отдел, призванный помогать разработчикам, и инженерам.

Конструкторский отдел помогает осуществить:

- Регистрацию проекта у производителя компонентов.
- Техническую поддержку проекта.
- Защиту от снятия компонента с производства.
- Оценку стоимости проекта по компонентам.
- Изготовление тестовой платы монтаж и пусконаладочные работы.



Тел: +7 (812) 336 43 04 (многоканальный)
Email: org@lifeelectronics.ru