

LT3496EUFD
Triple Boost or Buck-Boost
LED Driver

DESCRIPTION

WARNING!

Do not look directly at operating LED.
This circuit produces light that can damage eyes.

Demonstration circuit 1288 is a Triple Boost or Buck-Boost LED Driver featuring the LT3496EUFD. The LT3496 is a triple output DC/DC converter designed to operate as current sources for driving high current LEDs. For evaluating an LT3496 buck mode LED driver, use the demonstration circuit 986.

The board can be configured into either buck-boost (default) or boost mode. The current for each output is set at 200mA in either mode. The targeted input voltage PVIN range is 8V to 16V. The buck-boost circuit can tolerate an input voltage up to 40V when the LED string is on the high side. The part shuts down when the over-voltage threshold is reached. For a typical application with 5 LEDs totaling of 16V LED voltage, the circuit will operate until PVIN reaches 22V if the over-voltage protection is set to 38V. The buck-boost circuit with LEDs on the low side may not survive a 40V input transient. Applications with different input voltages and

load combinations can be demonstrated on this circuit with some board modifications. Call the LTC applications group for support.

Each of the three regulators on the demo board is independently operated. The PWM dimming feature of the LT3496 allows True Color PWM dimming with the dimming ratio of 5000:1. Additional analog dimming is possible.

Setting CTRL voltage to be less than 1V will set the current sense voltage to be one-tenth of CTRL voltage, therefore, reduce the LED current. The output current should not exceed the rated current of the LEDs used. The LED current thermal de-rating should be considered to protect the LEDs. Adjustable switching frequency allows optimization of the efficiency and the external component size.

The LT3496 datasheet gives complete description of the part, operation and application information. The datasheet must be read in conjunction with this quick start guide for working on or modifying the demo circuit 986.

Design files for this circuit board are available. Call the LTC factory.

 , LTC and LT are registered trademarks of Linear Technology Corporation.

PERFORMANCE SUMMARY Specifications are at TA = 25°C

SYMBOL	PARAMETER	CONDITIONS	MIN	TYP	MAX	UNITS
PV _{IN}	Power Input Supply	Buck-Boost Mode (LEDs on High Side) Boost Mode	8 8		40 VLED*	V
V _{IN}	Chip Bias Input Supply**		3		5.5	V
V _{OVP}	Output Over-voltage Protection				38	V
I _{LED}	Output LED Current, per Channel		188	196	204	mA
F _{SW}	Switching Frequency	FADJ=VREF	1.9	2.1	2.3	MHz
η	Conversion Efficiency	Buck-Boost Mode: I _{LED} = 200mA, PVIN=12V, VIN=3.3V, 5 LEDs Boost Mode: I _{LED} = 200mA, PVIN=12V, VIN=3.3V, 7 LEDs		80		%
PWM _D	PWM Dimming Ratio	PWM Frequency: 100Hz		5000:1		

* VLED is the forward voltage drop of a LED string

** V_{IN} of the demo board is limited by the choice of the input capacitor. The LT3496 input range is 3V-30V with transient protection to 40V. A lower V_{IN} helps to reduce the power dissipation in the chip.

MODE SETUP

	JP3, JP4, JP5	C2, C6, C8	C11, C12, C13	LED on High Side	LED on Low Side
Buck-Boost	=Buck-Boost	Not Install	Install	Short LEDnL+ and LEDnL-	Short LEDnH+ and LEDnH-
Boost	=Boost	Install	Not Install	N/A	Short LEDnH+ and LEDnH-

QUICK START PROCEDURE

Demonstration circuit 1288 is easy to set up to evaluate the performance of the LT3496EUFD. Refer to Figure 1 for proper measurement equipment setup and follow the procedure below:

1. With power off, select buck-boost or boost mode. Setup the board per the table in the "MODE SETUP" section. The default setting is for buck-boost mode.
2. Connect an input power supply to V_{IN} and GND. To achieve highest efficiency, a low voltage supply, such as 3.3V or 5V, is recommended.
3. With power off, connect a second input power supply to PV_{IN} and GND.
4. If an output channel *n* is not used, the PWM_n should be tied to GND.
5. Turn on PV_{IN} power supply.
6. Turn on V_{IN} power supply.

7. Check for the proper LED current and LED string voltage.
8. To observe PWM dimming, turn off all power supplies. Connect the PWM_n to a pulse generator. Then repeat step 5 – 7.

NOTE. If there is no output, turn off the power supplies. Check all connections.

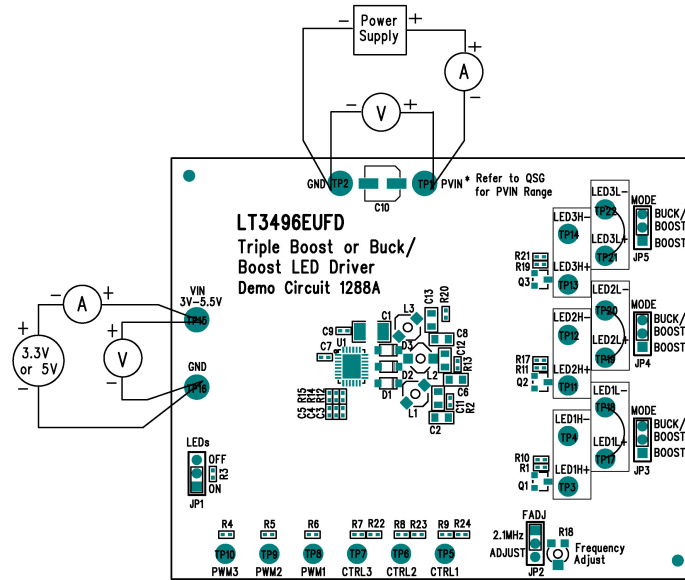

Figure 1. Proper Measurement Equipment Setup (LEDs on the High Side)

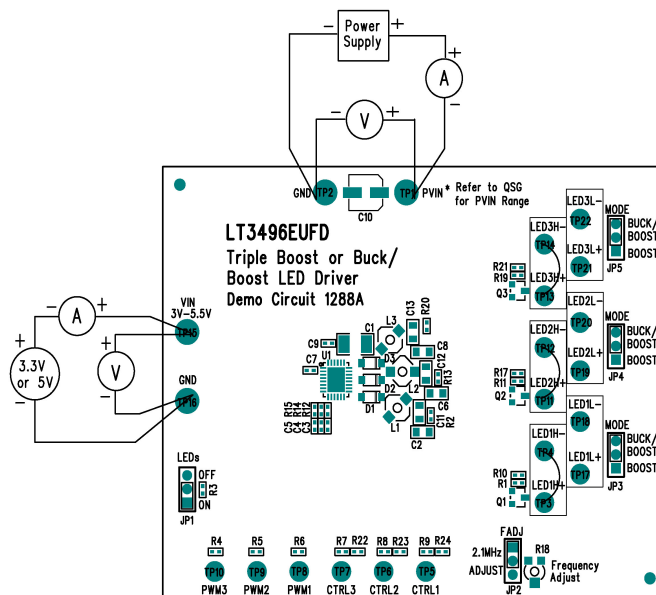
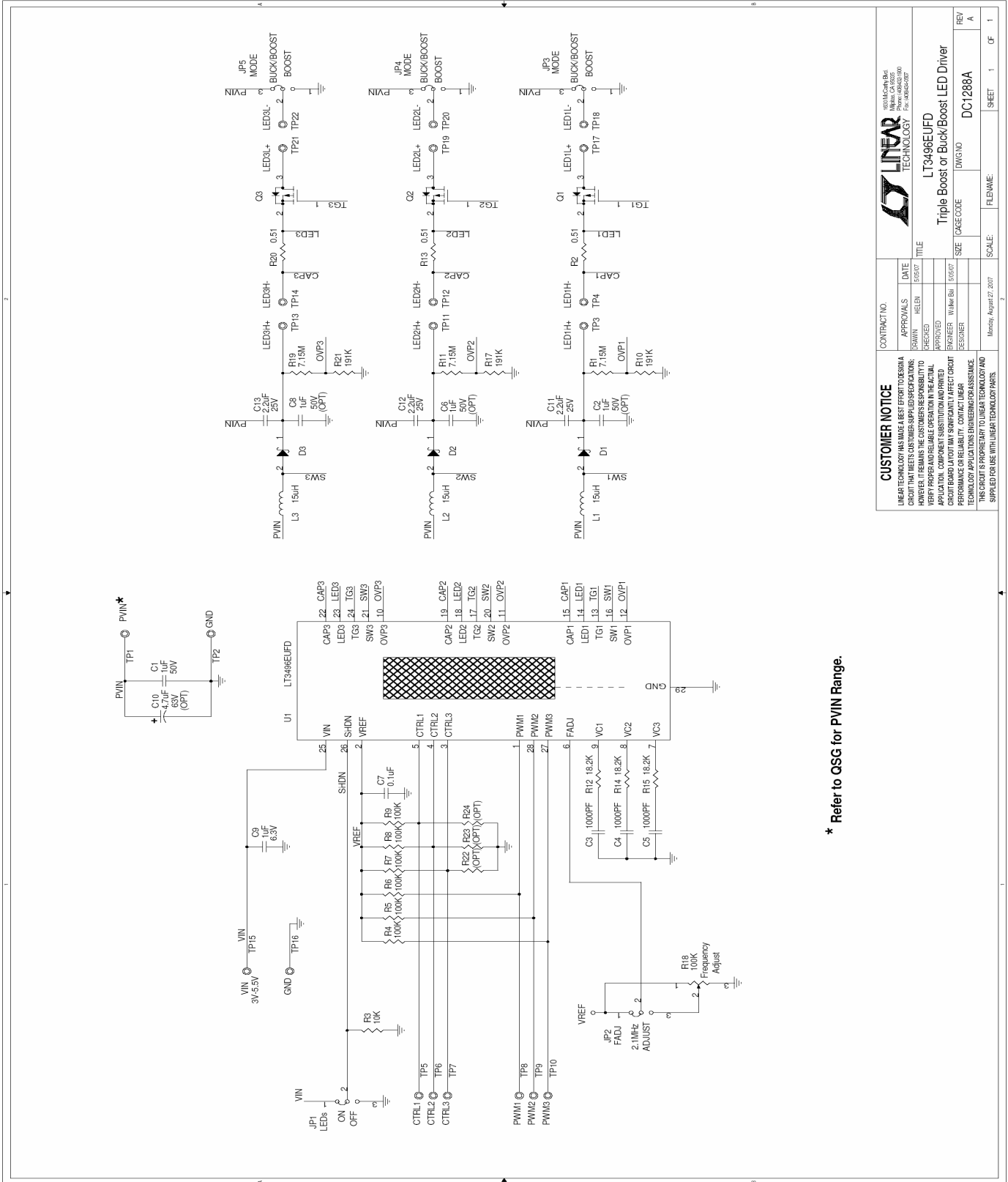

Figure 2. Proper Measurement Equipment Setup (LEDs on the Low Side)

LT3496EUF



* Refer to QSG for PVIN Range.

Компания «Life Electronics» занимается поставками электронных компонентов импортного и отечественного производства от производителей и со складов крупных дистрибьюторов Европы, Америки и Азии.

С конца 2013 года компания активно расширяет линейку поставок компонентов по направлению коаксиальный кабель, кварцевые генераторы и конденсаторы (керамические, пленочные, электролитические), за счёт заключения дистрибьюторских договоров

Мы предлагаем:

- Конкурентоспособные цены и скидки постоянным клиентам.
- Специальные условия для постоянных клиентов.
- Подбор аналогов.
- Поставку компонентов в любых объемах, удовлетворяющих вашим потребностям.
- Приемлемые сроки поставки, возможна ускоренная поставка.
- Доставку товара в любую точку России и стран СНГ.
- Комплексную поставку.
- Работу по проектам и поставку образцов.
- Формирование склада под заказчика.
- Сертификаты соответствия на поставляемую продукцию (по желанию клиента).
- Тестирование поставляемой продукции.
- Поставку компонентов, требующих военную и космическую приемку.
- Входной контроль качества.
- Наличие сертификата ISO.

В составе нашей компании организован Конструкторский отдел, призванный помогать разработчикам, и инженерам.

Конструкторский отдел помогает осуществить:

- Регистрацию проекта у производителя компонентов.
- Техническую поддержку проекта.
- Защиту от снятия компонента с производства.
- Оценку стоимости проекта по компонентам.
- Изготовление тестовой платы монтаж и пусконаладочные работы.



Тел: +7 (812) 336 43 04 (многоканальный)

Email: org@lifeelectronics.ru