



ZWX Series

Fanless open frame Multiple Output Power Supplies

TDK·Lambda

**Fanless multiple output power supplies
- ideal for industrial equipment**



ZWX Series

Fanless open frame Multiple Output Power Supplies

ZWX Series

Fanless power supplies makes you free from constraint.

The use of fans in traditional ATX power supplies restricts system layout and necessitates the use of forced air cooling. The ZWX design guarantees both operation and performance for increased flexibility and reliability.

Wide operating temperature for industrial equipment.

The ZWX Series can be used in ambient temperatures from -10°C to + 70°C with operation at 100% load from -10°C to 50°C. This specification is unique to the World's No.1 provider of industrial power supplies.

Low 36mm profile for mounting in a 1U rack.

The low profile, open frame format is able to be mounted in 1U racks, a desired feature for industrial equipment. In addition, two further options will be available in April 2008 - a "L bracket" and an "enclosed" type bringing further flexibility to the equipment design.

High efficiency - the proof of technology.

A 10% efficiency improvement has been obtained compared to existing products like Lambda's ZWQ series. An 84% efficiency rating is achieved by our unique circuit technology (patent pending). This high efficiency rating enables convection cooling in a low profile package.

A new format of highly reliable ATX power supplies Gives you more design freedom

Easy to use and highly reliable

Further flexibility is provided with guaranteed operation at zero load on any output. Many ATX power supplies require a minimum load on the main outputs, restricting operation and wasting power. Output power can be drawn from a combination of outputs (Wattbox format) provided the overall ratings are not exceeded. This feature allows designers to utilize the power of the ZWX series and produce a low acoustical noise design.

The use of pcb mount connectors on the power supply rather than a fixed cable harness allows the output wiring to be tailored to the system design.

High reliability is demanded by industrial equipment manufacturers and the power supply is critical to the

longevity of the overall equipment. Densel-Lambda, the World's No.1 power supply provider for industrial equipment, now offers an alternative to the traditional general purpose ATX power supply.

Model name identification method

ZWX 180 /□

Option

Blank : Standard type

/L1 : With chassis model

/L2 : With chassis model (reverse)

/A1 : With chassis and cover model

/A2 : With chassis and cover model (reverse)

(Refer to 6-2. Output Derating for details of option model.)

Rated Output Voltage

Series Name

Product line-up

Output CH	Model	ZWX180			ZWX240			ZWX300		
	Condition	Peak	Forced air	Convection	Peak	Forced air	Convection	Peak	Forced air	Convection
	Output power	180W	153W	90W	240W	204W	120W	300W	255W	150W
Output Voltage	Output Current			Output Current			Output Current			
V1	+3.3V	12.0A	8.4A	6.0A	14.0A	9.8A	7.0A	20.0A	14.0A	10.0A
V2	+5V	10.0A	7.0A	5.0A	12.0A	8.4A	6.0A	12.0A	8.4A	6.0A
V3	+12V	13.0A	9.0A	6.0A	16.0A	11.2A	8.0A	8.0A	5.6A	4.0A
V3-2	+12V	-	-	-	-	-	-	16.0A	11.2A	8.0A
V4	-12V	0.3A	0.3A	0.2A	0.3A	0.3A	0.2A	0.4A	0.4A	0.2A
V5	+5V	2.0A	2.0A	1.4A	2.0A	2.0A	1.4A	2.0A	2.0A	1.4A

ZWX180 Specifications

ITEMS/UNITS		MODEL		ZWX180				
				V1	V2	V3	V4	V5 (5VSB)
Input	Voltage Range (*4)	V	AC85-265					
	Frequency (*4)	Hz	47-63					
	Power Factor (100/200VAC) typ (*2)		0.99 / 0.93					
	Efficiency (100/200VAC) typ (*2)	%	81 / 84					
	Current (100/200VAC) typ (*2)	A	1.9 / 1.0					
	Inrush Current (100/200VAC) typ (*5)	A	14 / 28 at cold start (Ta=25°C)					
	Leakage Current (*3)(*11)	mA	Less than 0.75					
Output	Nominal Voltage	V	+3.3	+5	+12	-12	+5	
	Minimum Current	A	0					
	Maximum Current (Convection)	A	6	5	6	0.2	1.4	
	Maximum Current (Forced Air)	A	8.4	7	9	0.3	2	
	Maximum Peak Current (*1)	A	12	10	13	0.3	2	
	Maximum Power (Each CH, Convection)	W	19.8	25	72	2.4	7	
	Maximum Power (Convection)	W	Combined 32W			-		
	Maximum Power (Each CH, Forced Air)	W	27.7	35	108	3.6	10	
	Maximum Power (Forced Air)	W	Combined 54W			-		
	Maximum Peak Power (Each CH) (*1)	W	39.6	50	156	3.6	10	
	Maximum Peak Power (*1)	W	Combined 63W			-		
	Total Allowable Power (Convection)	W	90					
	Total Allowable Power (Forced Air)	W	153					
	Total Allowable Peak Power (*1)	W	180					
	Voltage Accuracy	%	±5					
	Maximum Line Regulation(*3)(*6)(*7)	mV	20	48			20	
	Maximum Load Regulation(*3)(*6)(*8)	mV	100	300			100	
	Maximum Ripple & Noise (-10°C < Ta < 0°C) (*3)(*6)	mVp-p	160	180			160	
	Maximum Ripple & Noise (0°C < Ta < 50°C) (*3)(*6)	mVp-p	120	150			120	
	Hold-up Time (100VAC) typ (*2)	ms	20					
Voltage Adjustable Range		Fixed						
Function	Over Current Protection (*9)	A	> 8.82	> 7.35	> 9.45	> 0.32	> 2.1	
	Over Voltage Protection (*10)		V1 : 114%-130% (3.76-4.3V), V2 : 115%-140% (5.74-7V), V3 : 112%-130% (13.4-15.6V)					
	Remote Sensing		Possible (V1 only)					
	Remote ON/OFF Control (PS_ON)		TTL compatible (H : Output inhibit, L : Output enable) : Designed to meet ATX standard.					
	Parallel Operation		-					
	Series Operation		-					
Environment	Operating Temperature (*12)	°C	-10 to +50 : 100%, 60 : 60%, 70 : 20%					
	Storage Temperature	°C	-30 to +85					
	Operating Humidity	% RH	30 - 90 (No dewdrop)					
	Storage Humidity	% RH	10 - 95 (No dewdrop)					
	Vibration		At no operating 10 - 55Hz (sweep for 1min), 19.6 m/s ² constant, X, Y, Z 1 hour each.					
	Shock		Less than 392 m/s ² at no operating.					
	Cooling (*12)		Convection cooling / forced air cooling (system air cooling) : 0.85 m ³ /min					
Isolation	Withstand Voltage		Input-FG : 2kVAC (20mA), Input-Output : 3kVAC (20mA), Output-FG : 500VAC (100mA) for 1min.					
	Isolation Resistance		More than 100M Ω at 25°C and 70%RH Output-FG : 500VDC					
Standards	Safety		Approved by UL60950-1, CSA60950-1, EN60950-1, EN50178 (OV II), Designed to meet DENAN (Section 2) at 100VAC only.					
	PFHC		Designed to meet IEC61000-3-2					
	EMI (*3)		EN55011/EN55022-B, FCC-ClassB, VCCI-B					
	Immunity		Designed to meet IEC61000-4-2, -3, -4, -5, -6, -8, -11					
Mechanical	Weight typ	g	500					
	Size (W x H x D)	mm	94 x 36 x 210 (Refer to outline drawing)					

(*1) Operating time at peak output is less than 5sec.

(Average output power and current are less than maximum output power and current.)

(*2) At total output power (Forced air) (V1=6.5A, V2=6.5A, V3=7.7A, V4=0.2A, V5=1.0A), Ta=25°C.

(*3) At total output power (Forced air).

(*4) For cases where conformance to various safety specs (UL, CSA, EN) are required, to be described as 100 - 240VAC (50/60Hz).

(*5) Not applicable for the inrush current to Noise Filter for less than 0.2ms.

(*6) Please refer to Fig. A for measurement of line & load regulation and ripple voltage.

(*7) 85 - 265VAC, constant load.

(*8) No load-Full load, constant input voltage.

(*9) Avoid to operate at overload or short circuit condition for more than 30 seconds.

V1, V2, V3 : OCP circuit will shut down output except V5 with delay (more than 5s), manual reset (PS_ON reset or re power on).

V4 : Constant current limit with automatic recovery.

V5 : Constant current limit in conjunction with all output with automatic recovery.

(*10) OVP circuit will shut down output, manual reset (PS_ON reset or re power on).

(*11) Measured by the each measuring method of UL, CSA, EN and DENAN (at 60Hz), Ta=25°C.

(*12) At forced air cooling, standard mounting. Refer to output derating curve.

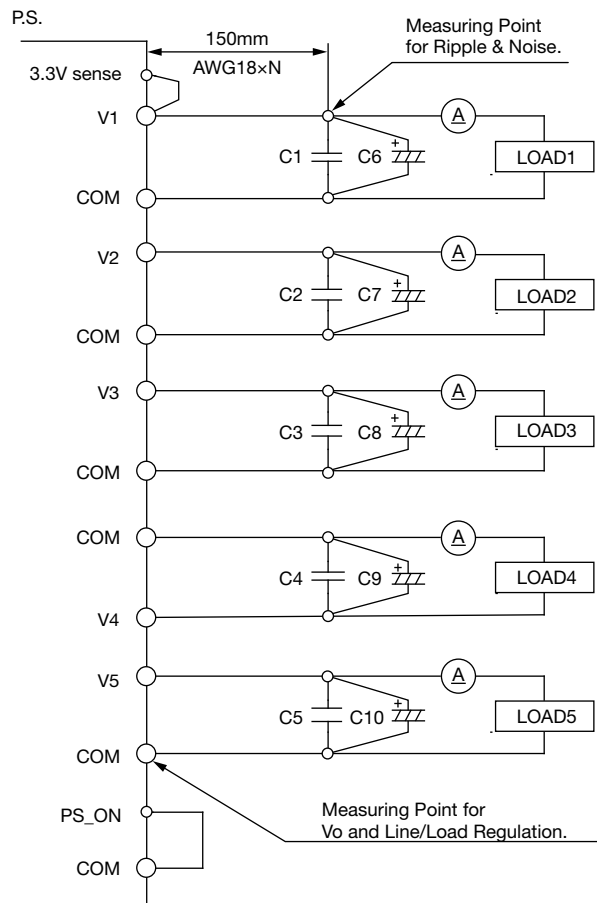

Measure with JEITA RC-9131 probe.
Bandwidth of scope : 100MHz

	Capacitance
C1, C2, C3, C4, C5 : Film Cap.	0.1 uF
C6, C7, C8, C9, C10 : Elec. Cap.	100 uF

Fig.A

ZWX180 Output Derating

OUTPUT DERATING CURVE (Convection Cooling)

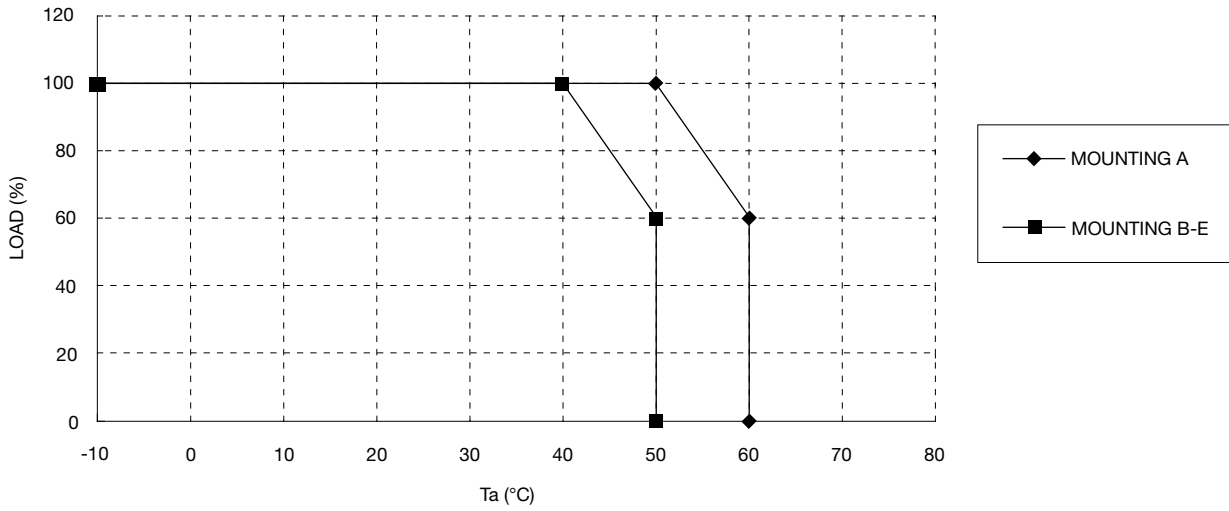

OUTPUT DERATING CURVE (Forced Air Cooling)

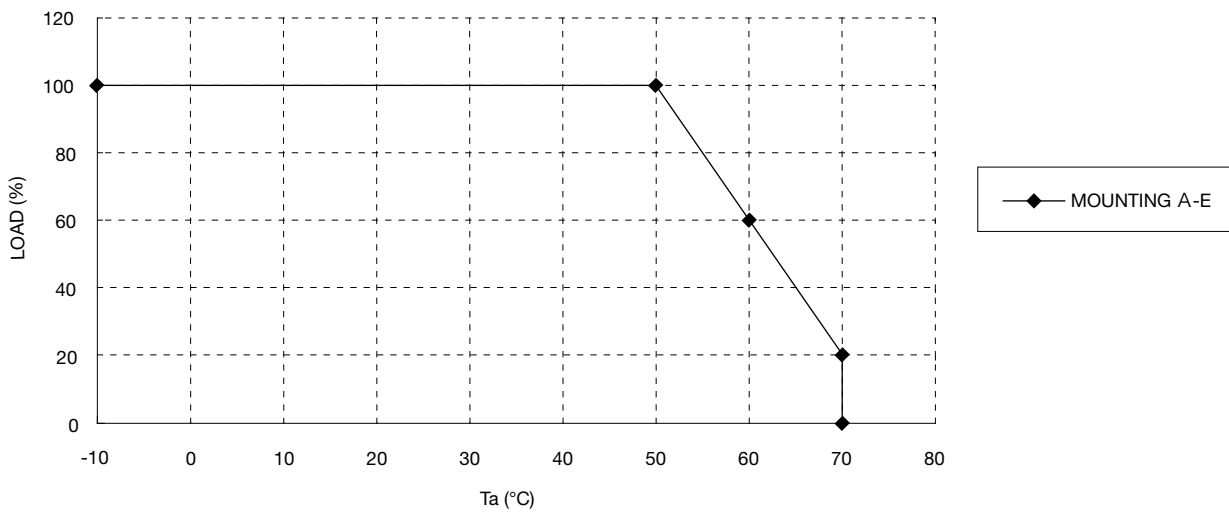

- MOUNTING A
- MOUNTING B
- MOUNTING C
- MOUNTING D
- MOUNTING E
- DON'T USE

(STANDARD MOUNTING)

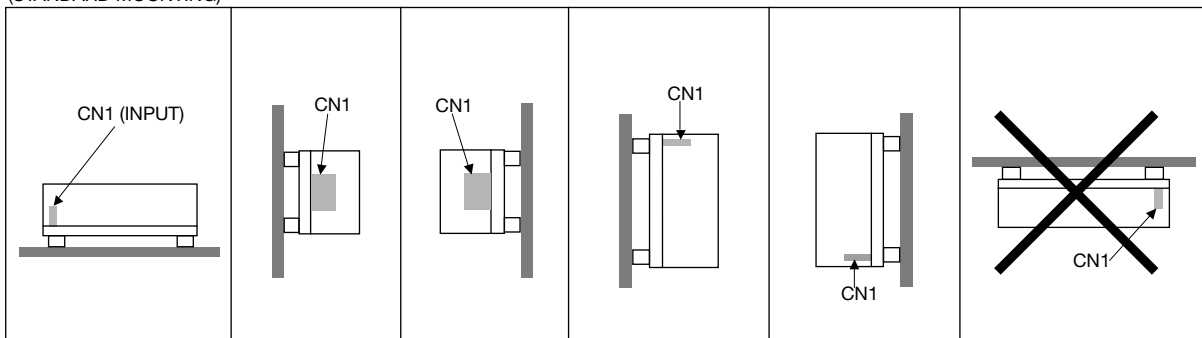

ZWX180 Outline Drawing

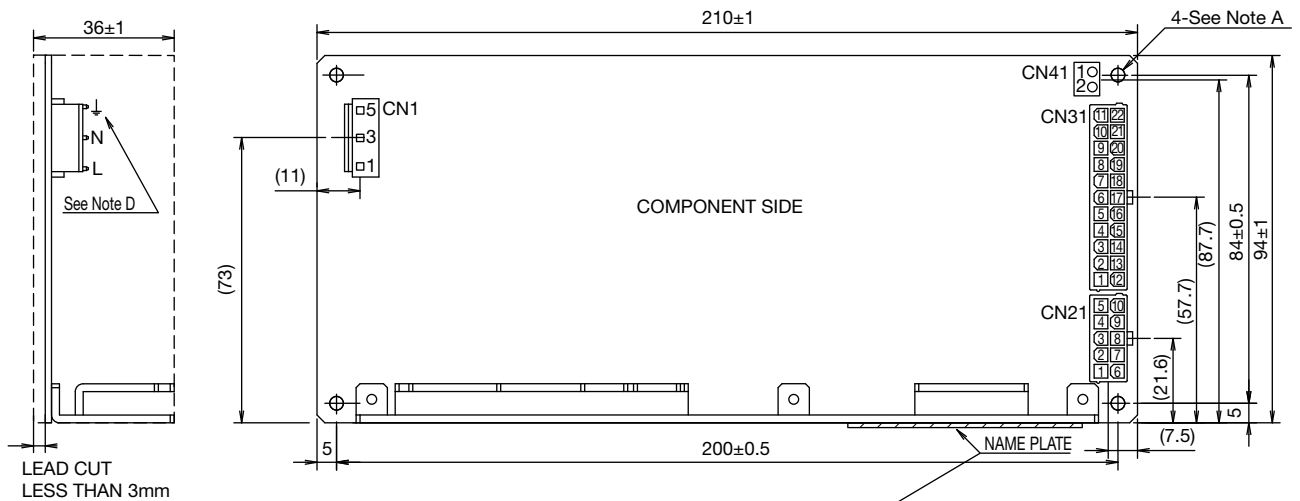

ZWX180

INPUT : 100-240VAC 2.3A (2.7Amax@Peak Power) 50 / 60Hz

OUTPUT :

Voltage		+3.3V	+5V	+12V	-12V	+5VSB	
MAX Current		8.4A	7.0A	9.0A	0.3A	2.0A	Total 153W
Power		54W	108W	108W	3.6W	10W	Total 180W
PEAK Current		12A	10A	13A	0.3A	2.0A	Total 180W
Power		63W	156W	156W	3.6W	10W	Total 180W

BAR CODE

Various safety mark will be indicated

Refer to www.densei-lambda.com for installation instructions.

TDK-Lambda
MADE IN JAPAN

See Note B

See Note C

NOTES

- A : 4-φ3.5 holes are for customer's chassis mounting holes.
All must be screwed in order to conform the vibration/EMI spec.
To keep the distance more than 5mm between PCB edge and customer's chassis.
- B : Model name, input voltage range, nominal output voltage, maximum output current and peak output current are shown here in accordance with the specifications.
- C : Country of manufacture will be shown here.
- D : ↓ is for safety ground connection.

CONNECTORS USED:

PART DESCRIPTION	PART NAME	MANUFACT.
PIN HEADER (INPUT SIDE CN1)	B3P5-VH(LF)(SN)	J.S.T.
PIN HEADER (OUTPUT SIDE CN21)	5566-10A-210	MOLEX
PIN HEADER (OUTPUT SIDE CN31)	5566-22A-210	MOLEX
PIN HEADER (OUTPUT SIDE CN41)	B2B-XH-AM(LF)(SN)	J.S.T.

*OUTPUT CURRENT OF EACH CONNECTOR PIN MUST BE LESS THAN 9A.

MATCHING HOUSINGS, PINS & TOOL (NOT INCLUDED WITH THE PRODUCT):

PART DESCRIPTION	PART NAME	MANUFACT.
SOCKET HOUSING (CN1)	VHR-5N	J.S.T.
SOCKET HOUSING (CN21)	5557-10R-210	MOLEX
SOCKET HOUSING (CN31)	5557-22R-210	MOLEX
SOCKET HOUSING (CN41)	XHP-2	J.S.T.
TERMINAL PINS (CN1)	SVH-21T-P1.1	J.S.T.
	BVH-21T-P1.1	
TERMINAL PINS (CN21, CN31)	5556PBT, 5556PBT	MOLEX
TERMINAL PINS (CN41)	BXH-001T-P0.6	J.S.T.
	SXH-001T-P0.6	
HAND CRIMPING TOOL (CN1)	YC-160R	J.S.T.
HAND CRIMPING TOOL (CN21, CN3)	AWG #18-#24	MOLEX
	AWG #22-#28	
HAND CRIMPING TOOL (CN41)	YC-110R	J.S.T.
	YRS-110	

CN PIN ASSIGN

CN21

PIN NO.	FUNCTION	PIN NO.	FUNCTION
5	+12V	10	+12V
4	COM	9	COM
3	COM	8	COM
2	+5V	7	+5V
1	+3.3V	6	N.C.

CN31

PIN NO.	FUNCTION	PIN NO.	FUNCTION
11	+5V SB	22	+5V
10	+5V	21	+5V
9	+5V	20	+5V
8	COM	19	COM
7	COM	18	COM
6	-12V	17	COM
5	+3.3V sense	16	COM
4	+3.3V	15	+3.3V
3	+3.3V	14	+3.3V
2	COM	13	COM
1	+12V	12	+12V

CN41

PIN NO.	FUNCTION
1	PWR_OK
2	PS_ON

ZWX240 Specifications

ITEMS/UNITS		MODEL	ZWX240				
			V1	V2	V3	V4	V5 (5VSB)
Input	Voltage Range (*4)	V	AC85-265				
	Frequency (*4)	Hz	47-63				
	Power Factor (100/200VAC) typ (*2)		0.99 / 0.93				
	Efficiency (100/200VAC) typ (*2)	%	81/ 84				
	Current (100/200VAC) typ (*2)	A	2.6 / 1.3				
	Inrush Current (100/200VAC) typ (*5)	A	14 / 28 at cold start (Ta=25°C)				
	Leakage Current (*3)(*11)	mA	Less than 0.75				
Output	Nominal Voltage	V	+3.3	+5	+12	-12	+5
	Minimum Current	A	0				
	Maximum Current (Convection)	A	7	6	8	0.2	1.4
	Maximum Current (Forced Air)	A	9.8	8.4	11.2	0.3	2
	Maximum Peak Current (*1)	A	14	12	16	0.3	2
	Maximum Power (Each CH, Convection)	W	23.1	30	96	2.4	7
	Maximum Power (Each CH)	W	32.3	42	134.4	3.6	10
	Maximum Peak Power (Each CH) (*1)	W	46.2	60	192	3.6	10
	Total Allowable Power (Convection)	W	120				
	Total Allowable Power (Forced Air)	W	204				
	Total Allowable Peak Power (*1)	W	240				
	Voltage Accuracy	%	±5				
	Maximum Line Regulation(*3)(*6)(*7)	mV	20	48			20
	Maximum Load Regulation(*3)(*6)(*8)	mV	100	300			100
	Maximum Ripple & Noise (-10°C < Ta < 0°C) (*3)(*6)	mVp-p	160	180			160
	Maximum Ripple & Noise (0°C < Ta < 50°C) (*3)(*6)	mVp-p	120	150			120
	Hold-up Time (100VAC) typ (*2)	ms	20				
Voltage Adjustable Range		Fixed					
Function	Over Current Protection (*9)	A	> 10.3	> 8.82	> 11.8	> 0.32	> 2.1
	Over Voltage Protection (*10)		V1 : 114%-130% (3.76-4.3V), V2 : 115%-140% (5.74-7V), V3 : 112%-130% (13.4-15.6V)				
	Remote Sensing		Possible (V1 only)				
	Remote ON/OFF Control (PS_ON)		TTL compatible (H : Output inhibit, L : Output enable) : Designed to meet ATX standard.				
	Parallel Operation		-				
	Series Operation		-				
	Operating Temperature (*12)	°C	-10 to +50 : 100%, 60 : 60%, 70 : 20%				
Environment	Storage Temperature	°C	-30 to +85				
	Operating Humidity	% RH	30 - 90 (No dewdrop)				
	Storage Humidity	% RH	10 - 95 (No dewdrop)				
	Vibration		At no operating 10 - 55Hz (sweep for 1min.) 19.6m/s ² constant, X, Y, Z 1hour each.				
	Shock		Less than 392m/s ² at no operating.				
	Cooling (*12)		Convection cooling / forced air cooling (system air cooling) : 0.85m ³ /min				
	Isolation	Withstand Voltage		Input-FG : 2kVAC(20mA), Input-Output : 3kVAC(20mA), Output-FG : 500VAC(100mA) for 1min.			
Isolation Resistance			More than 100M Ω at 25°C and 70%RH Output-FG : 500VDC				
Standards	Safety		Approved by UL60950-1, CSA60950-1, EN60950-1, EN50178 (OV II), Designed to meet DENAN (Section 2) at 100VAC only.				
	PFHC		Designed to meet IEC61000-3-2				
	EMI (*3)		EN55011/EN55022-B, FCC-ClassB, VCCI-B				
	Immunity		Designed to meet IEC61000-4-2, -3, -4, -5, -6, -8, -11				
Mechanical	Weight typ	g	650				
	Size (W x H x D)	mm	106 x 36 x 225 (Refer to outline drawing)				

(*1) Operating time at peak output is less than 5sec.

(Average output power and current are less than maximum output power and current.)

(*2) At total output power (Forced air) (V1=9.0A, V2=8.0A, V3=10.6A, V4=0.2A, V5=1.0A), Ta=25°C.

(*3) At total output power (Forced air).

(*4) For cases where conformance to various safety specs (UL, CSA, EN) are required, to be described as 100 - 240VAC (50/60Hz).

(*5) Not applicable for the inrush current to Noise Filter for less than 0.2ms.

(*6) Please refer to Fig. A for measurement of line & load regulation and ripple voltage.

(*7) 85 - 265VAC, constant load.

(*8) No load-Full load, constant input voltage.

(*9) Avoid to operate at overload or short circuit condition for more than 30 seconds.

V1, V2, V3 : OCP circuit will shut down output except V5 with delay (more than 5s), manual reset (PS_ON reset or re power on).

V4 : Constant current limit with automatic recovery.

V5 : Constant current limit in conjunction with all output with automatic recovery.

(*10) OVP circuit will shut down output, manual reset (PS_ON reset or re power on).

(*11) Measured by the each measuring method of UL, CSA, EN and DENAN (at 60Hz), Ta=25°C.

(*12) At forced air cooling, standard mounting. Refer to output derating curve.

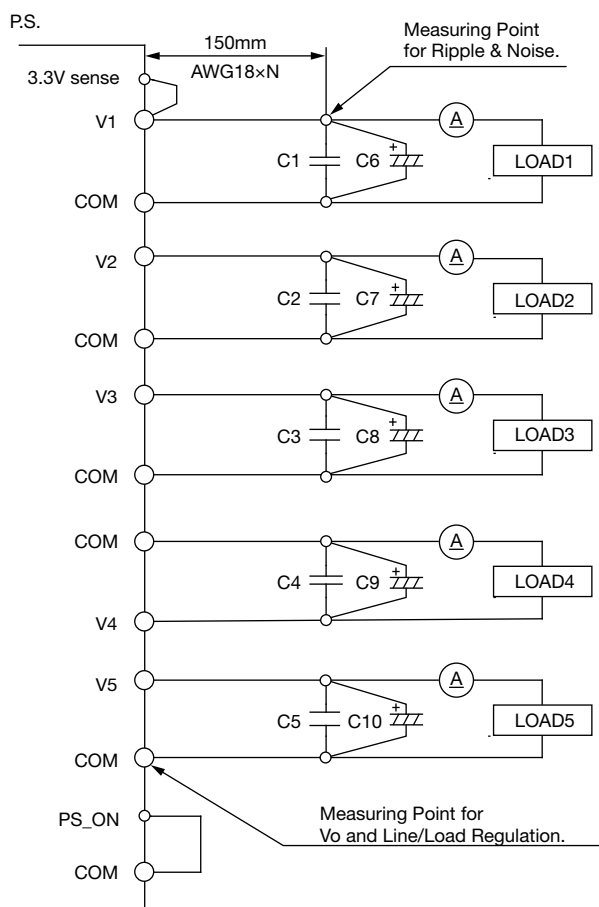

Measure with JEITA RC-9131 probe.
Bandwidth of scope : 100MHz

	Capacitance
C1, C2, C3, C4, C5 : Film Cap.	0.1 uF
C6, C7, C8, C9, C10 : Elec. Cap.	100 uF

Fig.A

ZWX240 Output Derating

OUTPUT DERATING CURVE (Convection Cooling)

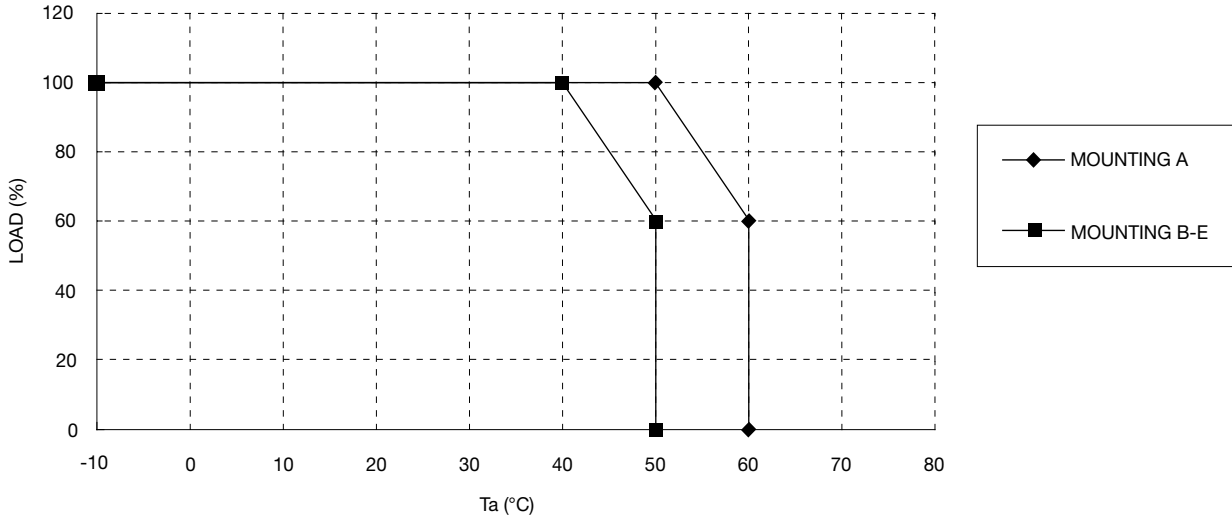

OUTPUT DERATING CURVE (Forced Air Cooling)

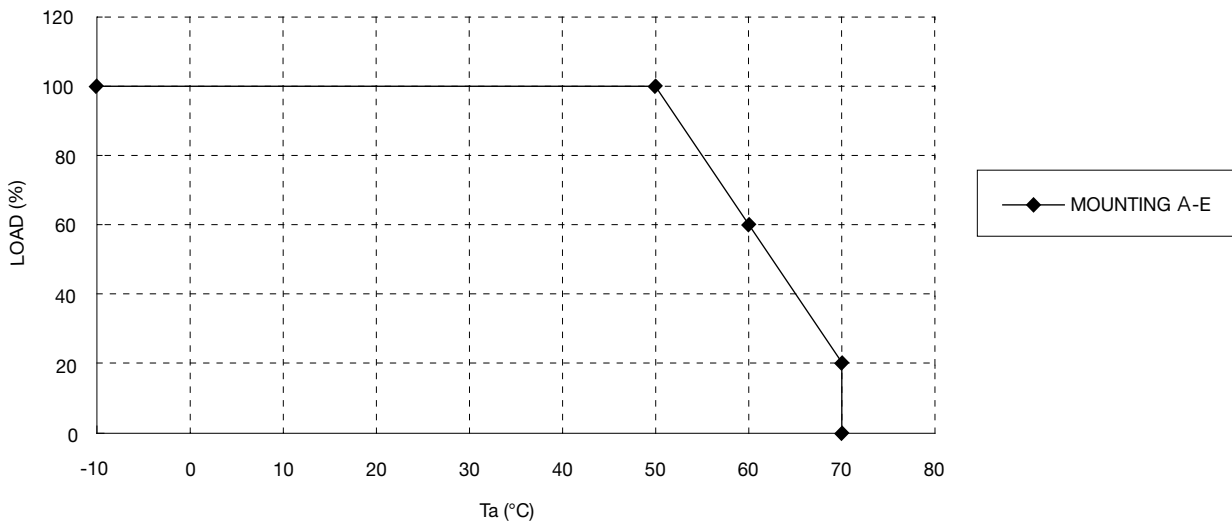

- MOUNTING A
- MOUNTING B
- MOUNTING C
- MOUNTING D
- MOUNTING E
- DON'T USE

(STANDARD MOUNTING)

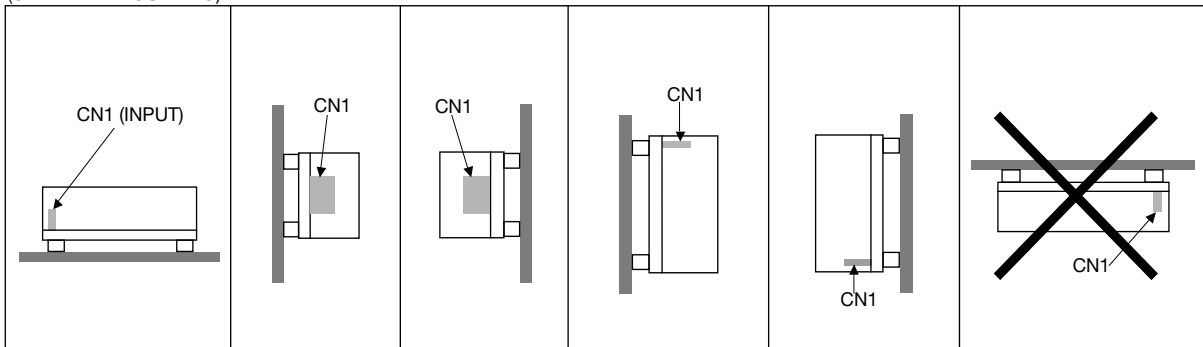

ZWX240 Outline Drawing

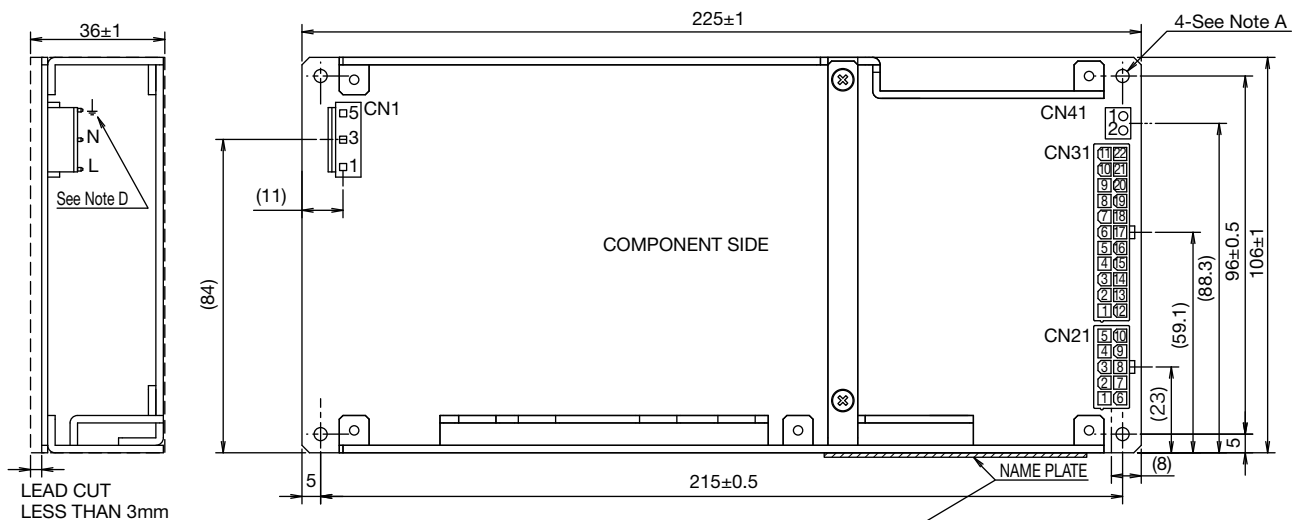

ZWX240

INPUT : 100-240VAC 3.0A (3.6Amax@Peak Power) 50 / 60Hz
OUTPUT :

Voltage		+3.3V	+5V	+12V	-12V	+5VSB		
MAX	Current	9.8A	8.4A	11.2A	0.3A	2.0A	Total	204W
	Power	32.3W	42.0W	134.4W	3.6W	10.0W		
PEAK	Current	14.0A	12.0A	16.0A	0.3A	2.0A	Total	240W
	Power	46.2W	60.0W	192.0W	3.6W	10.0W		

BAR CODE

Various safety mark will be indicated

Refer to www.dense-lambda.com for installation instructions.

TDK-Lambda
MADE IN JAPAN

See Note B

See Note C

NOTES

- A : 4- ϕ 3.5 holes are for customer's chassis mounting holes.
All must be screwed in order to conform the vibration/EMI spec.
- B : Model name, input voltage range, nominal output voltage, maximum output current and peak output current are shown here in accordance with the specifications.
- C : Country of manufacture will be shown here.
- D : \downarrow is for safety ground connection.

CONNECTORS USED:

PART DESCRIPTION	PART NAME	MANUFACT.
PIN HEADER (INPUT SIDE CN1)	B3P5-VH(LF)(SN)	J.S.T.
PIN HEADER (OUTPUT SIDE CN21)	5566-10A-210	MOLEX
PIN HEADER (OUTPUT SIDE CN31)	5566-22A-210	MOLEX
PIN HEADER (OUTPUT SIDE CN41)	B2B-XH-AM(LF)(SN)	J.S.T.

*OUTPUT CURRENT OF EACH CONNECTOR PIN MUST BE LESS THAN 9A.

MATCHING HOUSINGS, PINS & TOOL (NOT INCLUDED WITH THE PRODUCT):

PART DESCRIPTION	PART NAME	MANUFACT.
SOCKET HOUSING (CN1)	VHR-5N	J.S.T.
SOCKET HOUSING (CN21)	5557-10R-210	MOLEX
SOCKET HOUSING (CN31)	5557-22R-210	MOLEX
SOCKET HOUSING (CN41)	XHP-2	J.S.T.
TERMINAL PINS (CN1)	SVH-21T-P1.1	J.S.T.
	BVH-21T-P1.1	
TERMINAL PINS (CN21, CN31)	5556PBT, 5556PBTL	MOLEX
TERMINAL PINS (CN41)	BXH-001T-P0.6	J.S.T.
	SXH-001T-P0.6	
HAND CRIMPING TOOL (CN1)	YC-160R	J.S.T.
HAND CRIMPING TOOL (CN21, CN31)	AWG #18-#24	MOLEX
	AWG #22-#28	
HAND CRIMPING TOOL (CN41)	YC-110R	J.S.T.
	YRS-110	

CN PIN ASSIGN

CN21

PIN NO.	FUNCTION	PIN NO.	FUNCTION
5	+12V	10	+12V
4	COM	9	COM
3	COM	8	COM
2	+5V	7	+5V
1	+3.3V	6	N.C.

CN31

PIN NO.	FUNCTION	PIN NO.	FUNCTION
11	+5V SB	22	+5V
10	+5V	21	+5V
9	+5V	20	+5V
8	COM	19	COM
7	COM	18	COM
6	-12V	17	COM
5	+3.3V sense	16	COM
4	+3.3V	15	+3.3V
3	+3.3V	14	+3.3V
2	COM	13	COM
1	+12V	12	+12V

CN41

PIN NO.	FUNCTION
1	PWR_OK
2	PS_ON

ZWX300 Specifications

ITEMS/UNITS		MODEL	ZWX300					
			V1	V2	V3-1	V3-2	V4	V5 (5VSB)
Input	Voltage Range (*4)	V	AC85-265					
	Frequency	Hz	47-63					
	Power Factor (100/200VAC) typ (*2)		0.99 / 0.93					
	Efficiency (100/200VAC) typ (*2)	%	81 / 84					
	Current (100/200VAC) typ (*2)	A	3.2 / 1.6					
	Inrush Current (100/200VAC) typ (*5)	A	14 / 28 at cold start (Ta=25°C)					
	Leakage Current (*3)(*11)	mA	Less than 0.75					
Output	Nominal Voltage	V	+3.3	+5	+12	-12	+5	
	Minimum Current	A	0					
	Maximum Current (Convection)	A	10	6	4	8	0.2	1.4
	Maximum Current (Forced Air)	A	14	8.4	5.6	11.2	0.4	2
	Maximum Peak Current (*1)	A	20	12	8	16	0.4	2
	Maximum Power (Each CH, Convection)	W	33	30	48	96	2.4	7
	Maximum Power (Convection)	W	-		Combined 131W		-	
	Maximum Power (Each CH, Forced Air)	W	46.2	42	67.2	134.4	4.8	10
	Maximum Peak Power (Each CH) (*1)	W	66	60	96	192	4.8	10
	Maximum Peak Power (*1)	W	-		Combined 264W		-	
	Total Allowable Power (Convection)	W	150					
	Total Allowable Power (Forced Air)	W	255					
	Total Allowable Peak Power (*1)	W	300					
	Voltage Accuracy	%	±5					
	Maximum Line Regulation(*3)(*6)(*7)	mV	20	48			20	
	Maximum Load Regulation(*3)(*6)(*8)	mV	100	300			100	
	Maximum Ripple & Noise (-10°C < Ta < 0°C) (*3)(*6)	mVp-p	160	180			160	
	Maximum Ripple & Noise (0°C < Ta < 50°C) (*3)(*6)	mVp-p	120	150			120	
	Hold-up Time (100VAC) typ (*2)	ms	20					
	Voltage Adjustable Range		Fixed					
Function	Over Current Protection (*9)	A	> 14.7	> 8.82	> 5.88	> 11.8	> 0.42	> 2.1
	Over Voltage Protection (*10)		V1 : 114%-130% (3.76-4.3V), V2 : 115%-140% (5.74-7V), V3-1, V3-2 : 112%-130% (13.4-15.6V)					
	Remote Sensing		Possible (V1 only)					
	Remote ON/OFF Control (PS_ON)		TTL compatible (H : Output inhibit, L : Output enable) : Designed to meet ATX standard.					
	Parallel Operation		-					
	Series Operation		-					
Environment	Operating Temperature (*12)	°C	-10 to +50 : 100%, 60 : 60%, 70 : 20%					
	Storage Temperature	°C	-30 to +85					
	Operating Humidity	% RH	30 - 90 (No dewdrop)					
	Storage Humidity	% RH	10 - 95 (No dewdrop)					
	Vibration		At no operating 10 - 55Hz (sweep for 1min), 19.6 m/s ² constant, X, Y, Z 1hour each.					
	Shock		Less than 392 m/s ² at no operating.					
	Cooling (*12)		Convection cooling / forced air cooling (system air cooling) : 0.85 m ³ /min					
Isolation	Withstand Voltage		Input-FG : 2kVAC (20mA), Input-Output : 3kVAC (20mA), Output-FG : 500VAC (100mA) for 1min.					
	Isolation Resistance		More than 100M Ω at 25°C and 70%RH Output-FG : 500VDC					
Standards	Safety		Approved by UL60950-1, CSA60950-1, EN60950-1, EN50178 (OV II), Designed to meet DENAN (Section 2) at 100VAC only.					
	PFHC		Designed to meet IEC61000-3-2					
	EMI (*3)		EN55011/EN55022-B, FCC-ClassB, VCCI-B					
	Immunity		Designed to meet IEC61000-4-2, -3, -4, -5, -6, -8, -11					
Mechanical	Weight typ	g	800					
	Size (W x H x D)	mm	118 x 36 x 250 (Refer to outline drawing)					

(*1) Operating time at peak output is less than 5sec.

(Average output power and current are less than maximum output power and current.)

(*2) At total output power (Forced air) (V1=12A, V2=7.0A, V3-1=5.0A, V3-2=9.4A, V4=0.2A, V5=1.0A), Ta=25°C.

(*3) At total output power (Forced air).

(*4) For cases where conformance to various safety specs (UL, CSA, EN) are required, to be described as 100 - 240VAC (50/60Hz).

(*5) Not applicable for the inrush current to Noise Filter for less than 0.2ms.

(*6) Please refer to Fig. A for measurement of line & load regulation and ripple voltage.

(*7) 85 - 265VAC, constant load.

(*8) No load-Full load, constant input voltage.

(*9) Avoid to operate at overload or short circuit condition for more than 30 seconds.

V1, V2, V3-1 and V3-2 : OCP circuit will shut down output except V5 with delay (more than 5s), manual reset (PS_ON reset or re power on).

V4 : Constant current limit with automatic recovery.

V5 : Constant current limit in conjunction with all output with automatic recovery.

(*10) OVP circuit will shut down output, manual reset (PS_ON reset or re power on).

(*11) Measured by the each measuring method of UL, CSA, EN and DENAN (at 60Hz), Ta=25°C.

(*12) At forced air cooling, standard mounting. Refer to output derating curve.

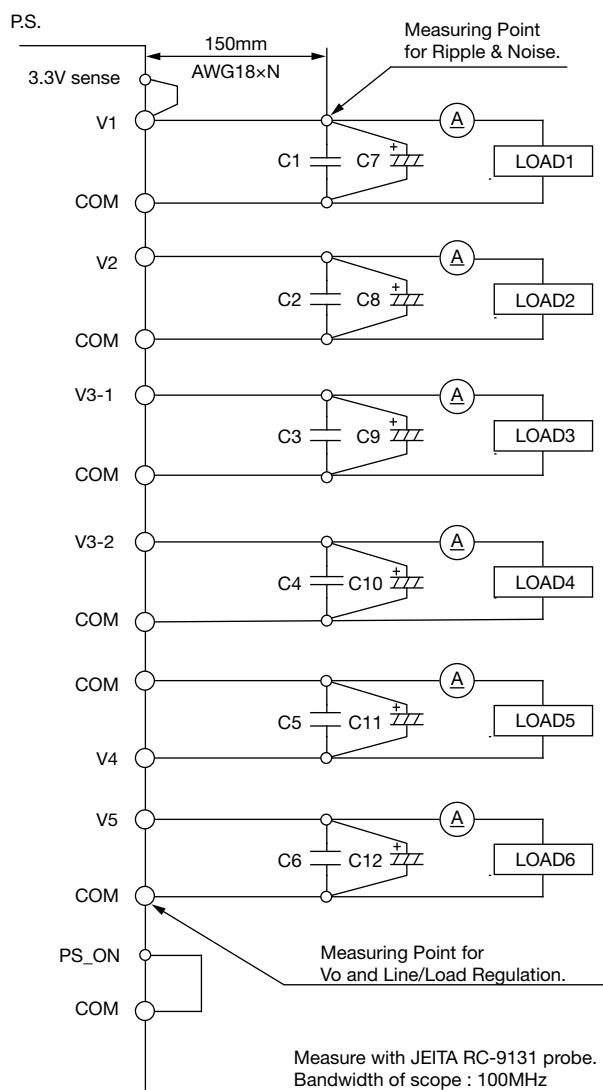

		Capacitance
C1, C2, C3, C4, C5, C6	: Film Cap.	0.1 μF
C7, C8, C9, C10, C11, C12	: Elec. Cap.	100 μF

Fig.A

ZWX300 Output Derating

OUTPUT DERATING CURVE (Convection Cooling)

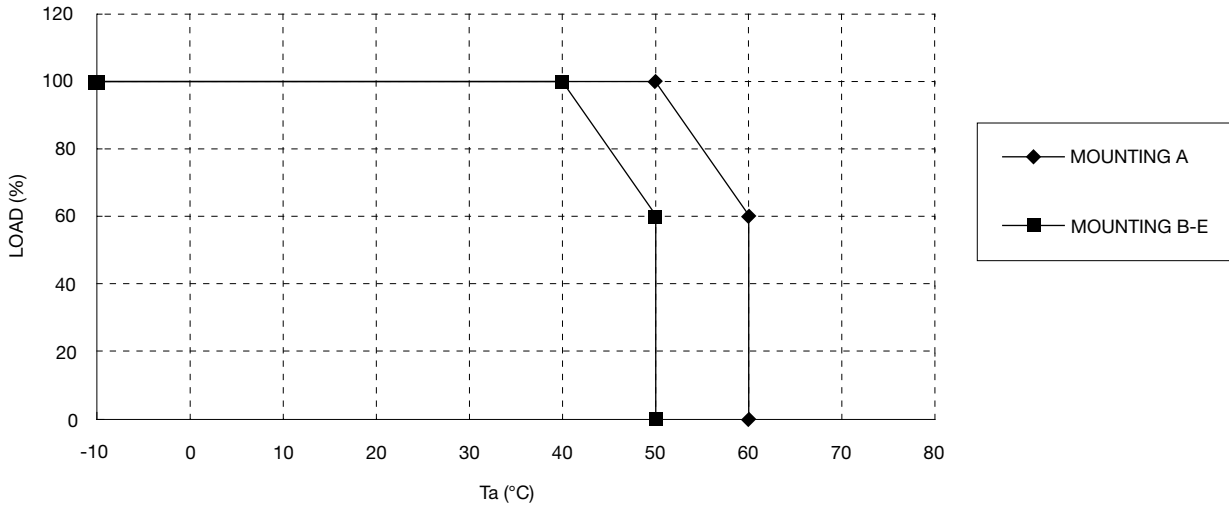

OUTPUT DERATING CURVE (Forced Air Cooling)

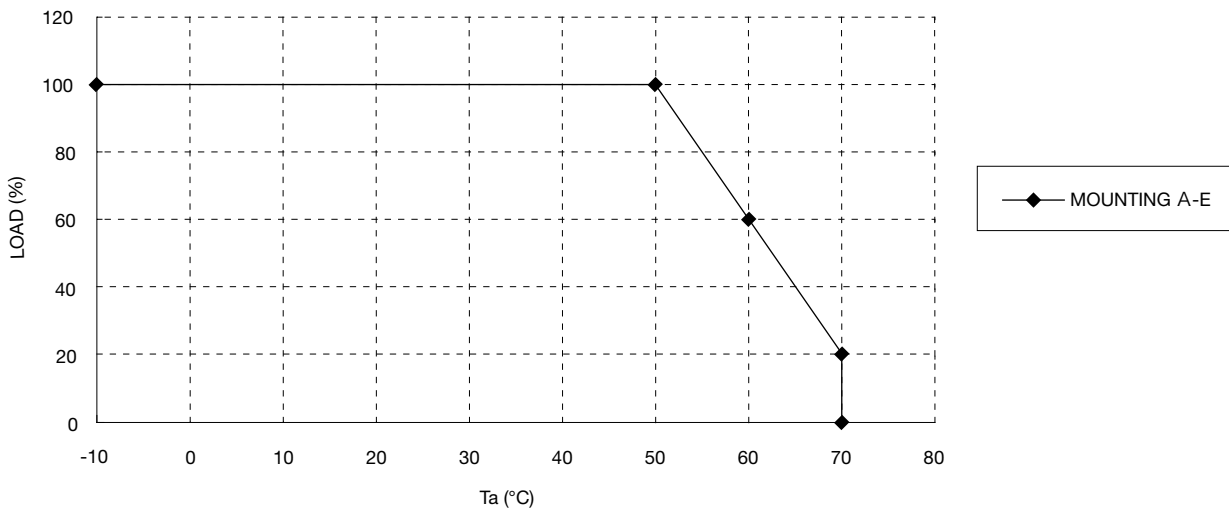

- MOUNTING A
- MOUNTING B
- MOUNTING C
- MOUNTING D
- MOUNTING E
- DON'T USE

(STANDARD MOUNTING)

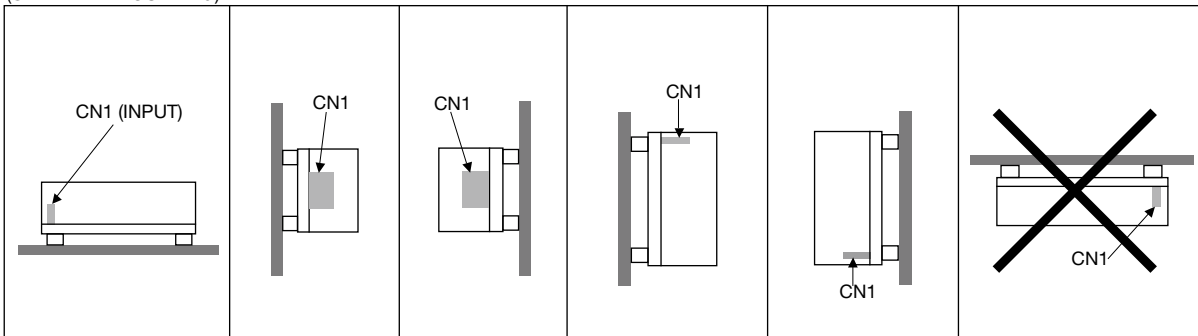

ZWX300 Outline Drawing

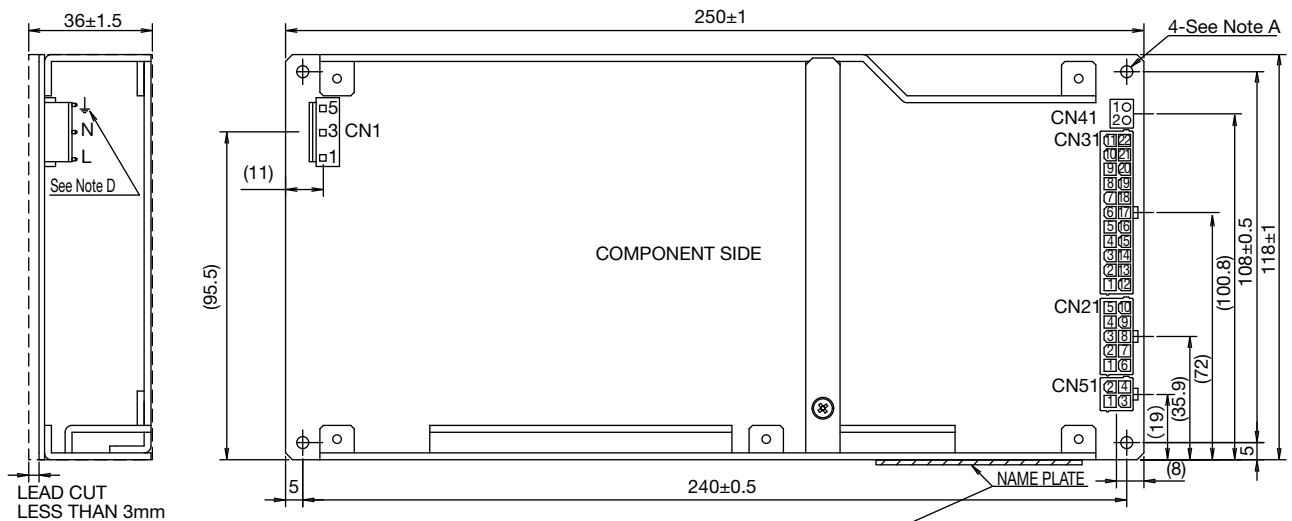

ZWX300

INPUT : 100-240VAC 3.8A (4.5Amax@Peak Power) 50 / 60Hz
 OUTPUT :

Voltage	+3.3V	+5V	+12V1	+12V2	-12V	+5VSB	Total
MAX Current	14.0A	8.4A	5.6A	11.2A	0.4A	2.0A	255W
Power	46.2W	42.0W	67.2W	134.4W	4.8W	10.0W	
PEAK Current	20.0A	12.0A	8.0A	16.0A	0.4A	2.0A	300W
Power	66.0W	60.0W	264.0W	4.8W	10.0W		

Refer to www.densei-lambda.com for installation instructions.

TDK-Lambda
MADE IN JAPAN

BAR CODE

Various safety mark will be indicated

See Note B

See Note C

NOTES

- A : 4-φ3.5 holes are for customer's chassis mounting holes.
All must be screwed in order to conform the vibration/EMI spec.
- B : Model name, input voltage range, nominal output voltage, maximum output current and peak output current are shown here in accordance with the specifications.
- C : Country of manufacture will be shown here.
- D : ↓ is for safety ground connection.

CONNECTORS USED:

PART DESCRIPTION	PART NAME	MANUFACT.
PIN HEADER (INPUT SIDE CN1)	B3P5-VH(LF)(SN)	J.S.T.
PIN HEADER (OUTPUT SIDE CN21)	5566-10A-210	MOLEX
PIN HEADER (OUTPUT SIDE CN31)	5566-22A-210	MOLEX
PIN HEADER (OUTPUT SIDE CN41)	B2B-XH-AM(LF)(SN)	J.S.T.
PIN HEADER (OUTPUT SIDE CN51)	5566-04A-210	MOLEX

*OUTPUT CURRENT OF EACH CONNECTOR PIN MUST BE LESS THAN 9A.

MATCHING HOUSINGS, PINS & TOOL (NOT INCLUDED WITH THE PRODUCT):

PART DESCRIPTION	PART NAME	MANUFACT.	
SOCKET HOUSING (CN1)	VHR-5N	J.S.T.	
SOCKET HOUSING (CN21)	5557-10R-210	MOLEX	
SOCKET HOUSING (CN31)	5557-22R-210	MOLEX	
SOCKET HOUSING (CN41)	XHP-2	J.S.T.	
SOCKET HOUSING (CN51)	5557-04R-210	MOLEX	
TERMINAL PINS (CN1)	SVH-21T-P1.1	J.S.T.	
	BVH-21T-P1.1		
TERMINAL PINS (CN41)	BXH-001T-P0.6	J.S.T.	
	SXH-001T-P0.6		
TERMINAL PINS (CN21, CN31, CN51)	5556PBT, 5556PBTL	MOLEX	
HAND CRIMPING TOOL (CN1)	YC-160R	J.S.T.	
HAND CRIMPING TOOL (CN41)	YC-110R	J.S.T.	
	YRS-110		
HAND CRIMPING TOOL (CN21, CN31, CN51)	AWG #18-#24	57027-5000	MOLEX
	AWG #22-#28	57064-5000	

CN PIN ASSIGN

CN21

PIN NO.	FUNCTION	PIN NO.	FUNCTION
5	+12V-1	10	+12V-1
4	COM	9	COM
3	COM	8	COM
2	+5V	7	+5V
1	+3.3V	6	N.C.

CN31

PIN NO.	FUNCTION	PIN NO.	FUNCTION
11	+5V SB	22	+5V
10	+5V	21	+5V
9	+5V	20	+5V
8	COM	19	COM
7	COM	18	COM
6	-12V	17	COM
5	+3.3V sense	16	COM
4	+3.3V	15	+3.3V
3	+3.3V	14	+3.3V
2	COM	13	COM
1	+12V-1	12	+12V-1

CN41

PIN NO.	FUNCTION
1	PWR_OK
2	PS_ON

CN51

PIN NO.	FUNCTION	PIN NO.	FUNCTION
2	COM	4	+12V-2
1	COM	3	+12V-2

Block Diagram

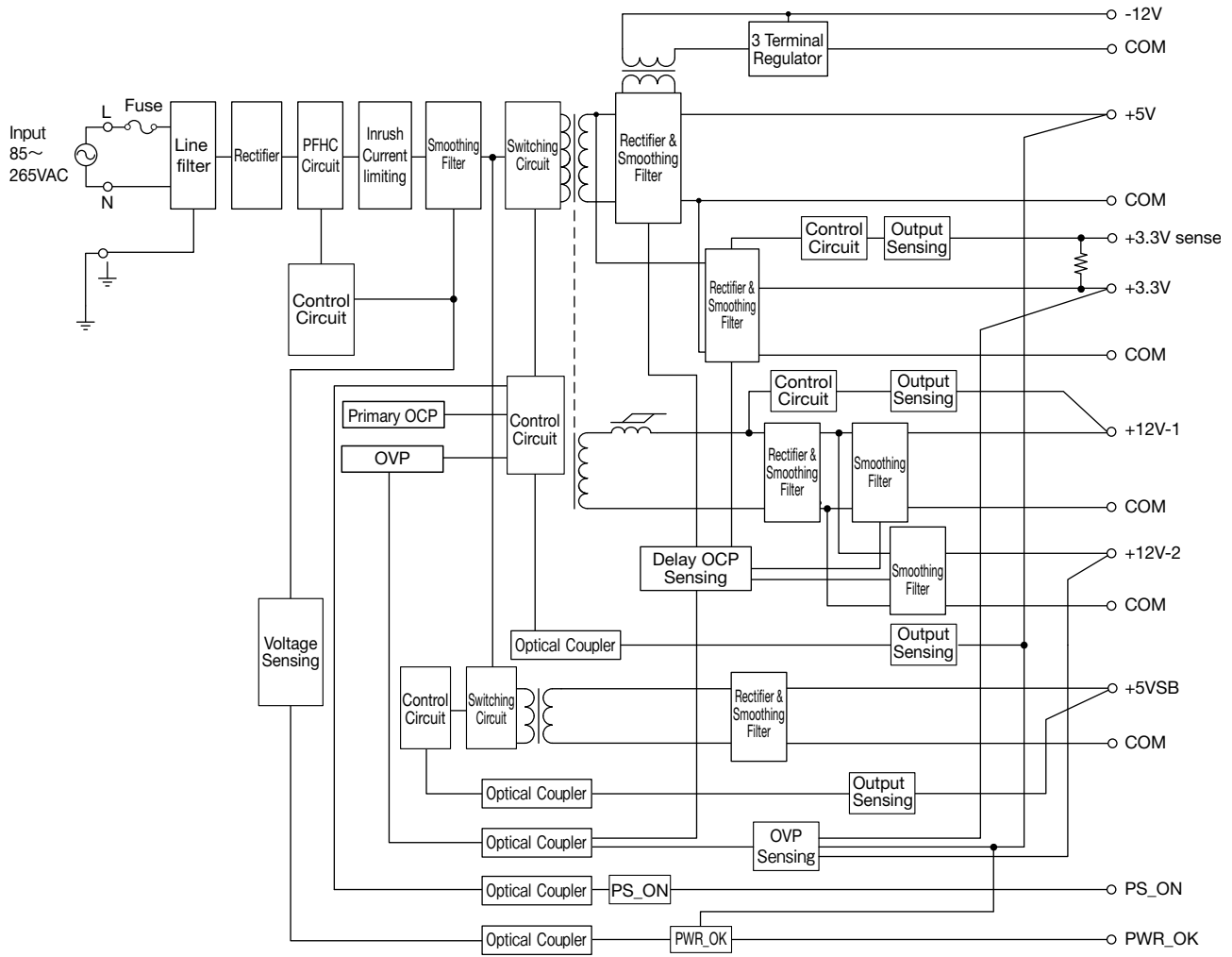

Sequence Time Chart

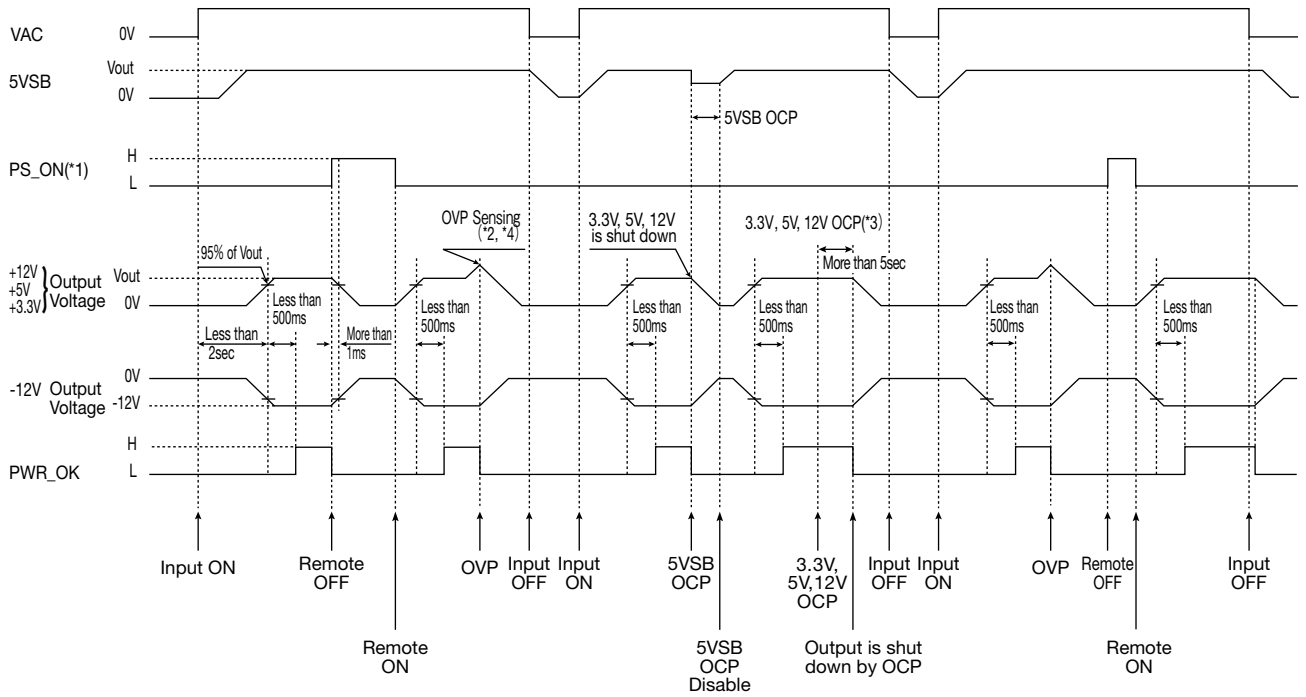

(*1) Level
 $2V \leq H \leq 5.5V$ or Open
 $0V \leq L \leq 0.8V$ or Short

(*2) OVP Limit
 3.3V : 114 ~ 130%
 5V : 115 ~ 140%
 12V : 112 ~ 130%

(*3) 3.3V, 5V, 12V OCP

●OCP Circuit will shut down output except V5 with delay (more than 5s), by operating at overload (Peak output current).

●OCP circuit will shut down output immediately except V5, by output short or operating at overload (more than total output power).

(*4) OTP

When ambient or internal temperature rises abnormally by overload etc, OTP function operates and output will be shut down in the same mode as OVP.

ZWX Series Instruction Manual

BEFORE USING THE POWER SUPPLY UNIT

Be sure to read this instruction manual thoroughly before using this product.

Pay attention to all cautions and warnings before using this product. Incorrect usage could lead to an electric shock, damage to the unit or a fire hazard.

DANGER

Never use this product in locations where flammable gas or ignitable substances are present. When a spark is generated, there are risks of igniting these substances and exploding.

WARNING

- This product is primarily designed and manufactured as Class 1 equipment. In the interest of safety, connect to earth before using the product.
- Do not touch this product and the internal components in operation or shortly after shut down. They may have high voltage or high temperature and as the product dissipates its heat so the surface of the product is hot. You may receive electric shock or burn.
- When this product is operating, keep your hands and face away from it as you may be injured by flying debris in the event of a fault.
- Do not make unauthorized changes to this product, otherwise you may receive electric shock and void your warranty.
- Do not drop or insert anything into this product. It might lead to a failure, fire and/or electric shock.
- Do not operate this product after it falls down.
- Do not use this product in the event of the emission of smoke or abnormal smell and sound etc. It might lead to fire and/or electric shock. In such cases, please contact us. Do not attempt to repair by yourself, as it is dangerous for the user.
- Do not operate this product in the presence of condensation. It might lead to fire and/or electric shock.

CAUTION

- This power supply is designed for use within an end product.
- Confirm connections to input/output terminals and signal terminals are correct as indicated in the instruction manual before switching on.
- Input voltage, output current, output power, ambient temperature and ambient humidity should be kept within specifications, otherwise the product will be damaged.
- Do not operate and store this product in an environment where condensation might occur. In such case, waterproof treatment is necessary.

- Do not use this product in environment with a strong electromagnetic field, corrosive gas or conductive substances.
- For applications which require very high reliability (nuclear related equipment, traffic control equipment, medical equipment, etc.), it is necessary to provide a fail-safe mechanism in the end equipment.
- Do not inject abnormal voltages into the output or signal of this product. The injection of reverse voltage or over voltage exceeding nominal output voltage into the output or signal terminals might cause damage to internal components.
- Never operate the product under over current or short-circuit conditions for more than 30 seconds, or outside its specified Input Voltage Range. Insulation failure, smoking, burning or other damage may occur.
- This product contains a printed circuit board utilizing surface mounted devices. PCB stress such as bending, twisting etc. could cause damage. Therefore, please handle with care.
- When handling this product, hold the board edge and take not to touch the component side. When installing this product in apparatus or equipment, mount it on spacers.
- The output of this product is considered to be a hazardous energy level. (The voltage is 2V or more and the power is 240VA or more.) It must not be made accessible to users. Protection must be provided for service engineers against indirect contact with the output terminals and/or to prevent tools being dropped across them. While working on this product, the AC input power must be switched off and the input and output voltage should be zero.
- When using for personal computer (hereinafter called PC), cut input voltage with you may stop PC. When the AC switch is cut while PC is operating, PC might be damaged. Especially, when the AC switch is cut while the memory such as hard disks is operating, you may damage data in a PC.
- This product has used Power Thermistor to protect the circuit from Inrush Current. Frequent repetition of input might cause damage to internal components because of generating surge current.
- Breaking of internal fuse is considered internal failure. In such cases, please contact us.
- The information in this document is subject to change without prior notice. Please refer to the latest version of the data sheet, etc., for the most up-to-date specifications of the product.
- No part of this document may be copied or reproduced in any form without prior written consent of Densel-Lambda.

Note: CE MARKING

CE Marking when applied to a product covered by this handbook, indicates compliance with the low voltage directive (2006/95/EC) which complies with EN60950-1.

1. Model Name Identification Method

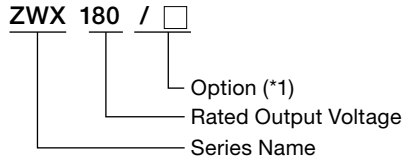

- (*1)
 Blank : Standard type
 /L1 : With chassis model
 /L2 : With chassis model (reverse)
 /A1 : With chassis and cover model
 /A2 : With chassis and cover model (reverse)
 (Refer to 6-2. Output Derating for details of option model.)

2. Terminal Explanation

1 ZWX180, ZWX240 and ZWX300 Terminal Explanation

ZWX180

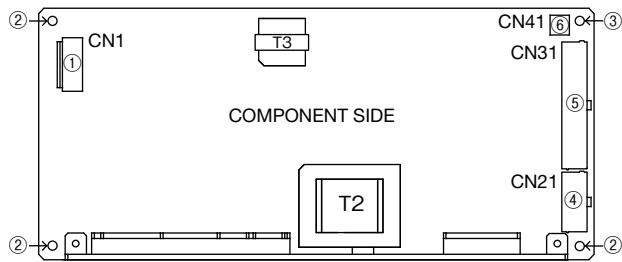

- ① Input Terminal : CN1 (Refer to 2-2.)
- ② Mounting hole : hole diameter : $\phi 3.5\text{mm}$
 This hole is connected to protective earth of CN1.
 Must be connected to electrically conductive spacer.
 The mounting surface of the spacer should be within max $\phi 8\text{mm}$.
- ③ Mounting hole : hole diameter : $\phi 3.5\text{mm}$
 This hole is not connected to protective earth of CN1.
- ④ Output Terminal : CN21 (+3.3V, +5V and -12V) (Refer to 2-3.)
- ⑤ Output Terminal : CN31 (+3.3V, +5V, +12V, -12V, 5V SB and +3.3Vsense) (Refer to 2-3.)
- ⑥ Signal Terminal : CN41 (PS_ON and PWR_OK) (Refer to 2-3.)

ZWX240

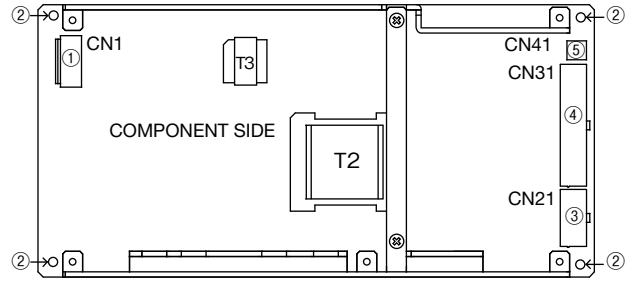

- ① Input Terminal : CN1 (Refer to 2-2.)
- ② Mounting hole : hole diameter : $\phi 3.5\text{mm}$
 This hole is connected to protective earth of CN1.
 Must be connected to electrically conductive spacer.
 The mounting surface of the spacer should be within max $\phi 8\text{mm}$.
- ③ Output Terminal : CN21 (+3.3V, +5V and -12V) (Refer to 2-3.)
- ④ Output Terminal : CN31 (+3.3V, +5V, +12V, -12V, 5V SB and +3.3V sense) (Refer to 2-3.)
- ⑤ Signal Terminal : CN41 (PS_ON and PWR_OK) (Refer to 2-3.)

ZWX300

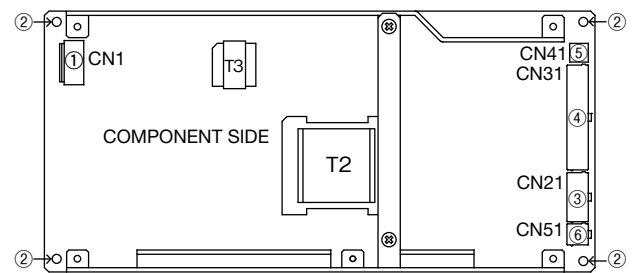

- ① Input Terminal : CN1 (Refer to 2-2.)
- ② Mounting hole : hole diameter : $\phi 3.5\text{mm}$
 This hole is connected to protective earth of CN1.
 Must be connected to electrically conductive spacer.
 The mounting surface of the spacer should be within max $\phi 8\text{mm}$.
- ③ Output Terminal : CN21 (+3.3V, +5V and +12V-1) (Refer to 2-3.)
- ④ Output Terminal : CN31 (+3.3V, +5V, +12V-1, -12V, 5V SB and +3.3Vsense) (Refer to 2-3.)
- ⑤ Signal Terminal : CN41 (PS_ON and PWR_OK) (Refer to 2-3.)
- ⑥ Output Terminal : CN51 (+12V-2) (Refer to 2-3.)

2 CN1 Connector Pin Assignment and Function (ZWX Series)

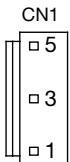
	Pin No.	Function		Note
	1	L	AC input terminal live line	Fuse in line
	3	N	AC input terminal neutral line	-
	5	↓	↓ terminal (protective earth)	-

3 CN21, CN31, CN41 and CN51 Connector Pin Assignment and Function (ZWX Series)

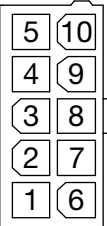
	Pin No.	Function	
	1	+3.3V	+3.3V output terminal
	2	+5V	+5V output terminal
	3	COM	GND terminal (All of COM are connected in this power supply unit.)
	4	COM	GND terminal (All of COM are connected in this power supply unit.)
	5	+12V	+12V output terminal (ZWX180 and ZWX240)
		+12V-1	+12V output terminal (ZWX300 only)
	6	-	NC (Connected to +3.3V inside PS.)
	7	+5V	+5V output terminal
	8	COM	GND terminal (All of COM are connected in this power supply unit.)
	9	COM	GND terminal (All of COM are connected in this power supply unit.)
10	+12V	+12V output terminal (ZWX180 and ZWX240)	
	+12V-1	+12V output terminal (ZWX300 only)	

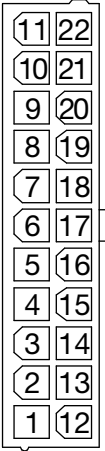
	Pin No.	Function	
	1	+12V	+12V output terminal (ZWX180 and ZWX240)
		+12V-1	+12V output terminal (ZWX300 only)
	2	COM	GND terminal (All of COM are connected in this power supply unit.)
	3	+3.3V	+3.3V output terminal
	4	+3.3V	+3.3V output terminal
	5	+3.3V sense	+3.3V output sensing terminal
	6	-12V	-12V output terminal
	7	COM	GND terminal (All of COM are connected in this power supply unit.)
	8	COM	GND terminal (All of COM are connected in this power supply unit.)
	9	+5V	+5V output terminal
	10	+5V	+5V output terminal
	11	+5V SB	+5V SB output terminal
	12	+12V	+12V output terminal (ZWX180 and ZWX240)
		+12V-1	+12V output terminal (ZWX300 only)
	13	COM	GND terminal (All of COM are connected in this power supply unit.)
	14	+3.3V	+3.3V output terminal
	15	+3.3V	+3.3V output terminal
	16	COM	GND terminal (All of COM are connected in this power supply unit.)
	17	COM	GND terminal (All of COM are connected in this power supply unit.)
	18	COM	GND terminal (All of COM are connected in this power supply unit.)
	19	COM	GND terminal (All of COM are connected in this power supply unit.)
20	+5V	+5V output terminal	
21	+5V	+5V output terminal	
22	+5V	+5V output terminal	

	Pin No.	Function	
	1	PWR_OK	PWR_OK signal terminal
2	PS_ON	PS_ON signal terminal	

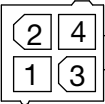
	Pin No.	Function	
	1	COM	GND terminal (All of COM are connected in this power supply unit.)
	2	COM	GND terminal (All of COM are connected in this power supply unit.)
	3	+12V-2	+12V output terminal (ZWX300 only)
4	+12V-2	+12V output terminal (ZWX300 only)	

*Output current of each connector pin must be less than 9A.

3. Terminal Connecting Method

Take care of the input wiring. Wrong connection cause the power supply spoil.

- Input must be off when making connections.
- Connect ↓ terminal of input connector and mounting hole to protective earth of the equipment.
- The output load line and input line shall be separated to improve noise sensitivity.

- When connecting or removing connector, do not apply stress to PCB.
- Use the input/output connector specified in outline drawing. Also, use recommended crimping tool. Connector is not included with this product.

INPUT/OUTPUT CONNECTOR (Common ZWX Series)

	CONNECTOR	MATCHING HOUSING	TERMINAL PINS		MANUFACT
Input Terminal (CN1)	B3P5-VH(LF)(SN)	VHR-5N	AWG18-22	SVH-21T-P1.1 or BVH-21T-P1.1	J.S.T.
Output Terminal (CN21)	5566-10A-210	5557-10R-210	AWG18-24	5556T, 5556TL	MOLEX
			AWG22-28	5556T2, 5556T2L	
Output Terminal (CN31)	5566-22A-210	5557-22R-210	AWG18-24	5556T, 5556TL	MOLEX
			AWG22-28	5556T2, 5556T2L	
Signal Terminal (CN41)	B2B-XH-AM(LF)(SN)	XHP-2	AWG22	BXH-001T-P0.6	J.S.T.
			AWG22	SXH-001T-P0.6	
Output Terminal (CN51) (ZWX300 only)	5566-04A-210	5557-04R-210	AWG18-24	5556T, 5556TL	MOLEX
			AWG22-28	5556T2, 5556T2L	

Common ZWX Series BASIC CONNECTION

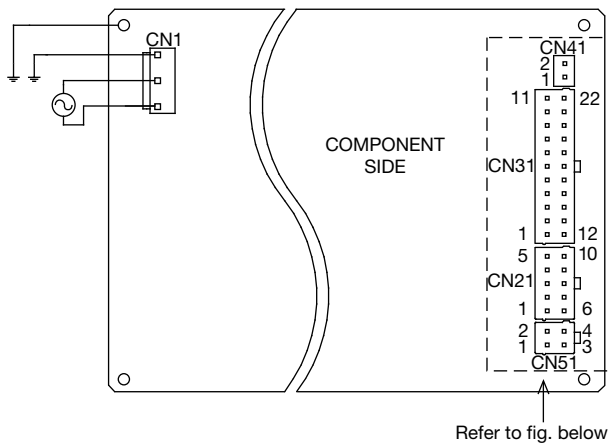

BASIC CONNECTION OF OUTPUT SIDE

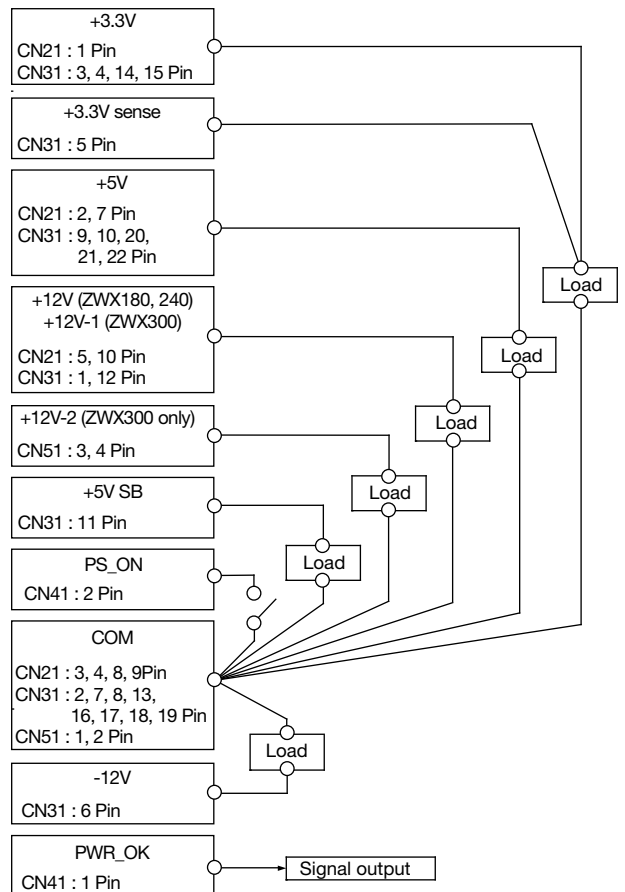

* All of COM are connected in this power supply unit.

4. Specification of Input and Output Signal

Timing chart

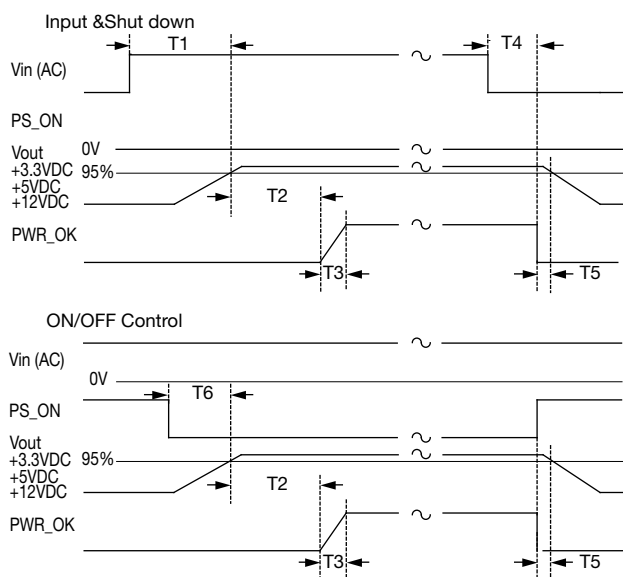

Time characteristic of signal

- T1 < 2s
- 100ms ≤ T2 ≤ 500ms
- T3 ≤ 10ms
- T4 ≥ 16ms
- T5 ≥ 1ms
- T6 < 500ms

1 PS_ON

When the "L" is input, +3.3V, +5V, +12V (only ZWX300 has +12V-1, +12V-2) and -12V are output.

When the "H" or "OPEN" is input, +3.3V, +5V, +12V (only ZWX300 has +12V-1, +12V-2) and -12V are stopped and reset the shut down latch.

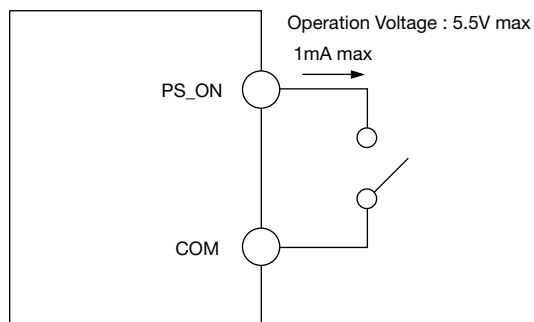

Control mode

Output	PS_ON Level to COM
ON	Short or Low : 0V - 0.8V
OFF	Open or High : 2.0V - 5.5V

2 PWR_OK

When the input voltage and +5V output voltage become "ON", the "H" signal is output.

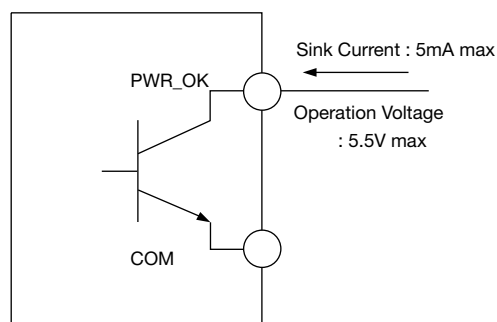

PWR_OK Signal	Output	PS_ON Level to COM
High (2.4V-5.5V)	ON	Short or Low : 0V - 0.8V
Low (<0.4V)	OFF	Open or High : 2.0V - 5.5V

5. Explanation of Function and Precautions

1 Input Voltage Range

Input voltage range is single phase 85-265VAC (47-63Hz).
 Input voltage which is out of specification may cause unit damage.
 For cases where conformance to various safeties required, described as 100-240VAC (50/60Hz).

2 Output Voltage Range

Output voltage is fixed. It is not adjustable. Output voltage in the specification is value on the point of the output connector.

3 Inrush Current

This series equipped power thermistor to limit the inrush current (ZWX180, 240). ZWX180, 240 are power thermistor method

so that higher current will flow at higher ambient temperature or re-input condition. Please select input switch and fuse carefully with the high temperature and re-input the power condition. The inrush value is under cold start at 25°C in the specification.

4 Wattbox

ZWX series is a Watt box power supply. Watt box can supply the total output power specified in the spec sheet with free combinations for each output CH power within the each CH spec. (Each rating at forced air cooling, convention cooling and peak power at forced air cooling.)

However, there is some limitation for +3.3VCH and +5VCH (ZWX180 only) and +12V-1 and +12V-2 (ZWX300 only). Please take note.

5 Over Voltage Protection (OVP)

The OVP function (inverter shut down method, manual reset type) is provided. As for +3.3V, +5V and +12V (+12V-1 and +12V-2 for ZWX300), the over voltage protection circuit is built-in. OVP will operate either one output voltage trigger the OVP limit (V1 : 114% -130%, V2 : 115% -140%, V3 : 112% -130%), all the outputs (except 5V SB) will be shut down. Outputs will recover after line re-power on (line off a few minutes) or reset the PS_ON signal. Note that for both -12V and 5VSB have no OVP function. In addition, the setting value of OVP is fixed and not adjustable. Pay attention not to apply higher voltage externally to the output terminal to avoid unit failure. In case of inductive load, put protective diode in series to the output power line.

6 Over Current Protection (OCP Delay Shut Down)

Outputs will be shut down after the delay time shown in next table in condition over current or output short. Outputs will recover automatically when the over current or output short condition removed within the delay time. Outputs will recover after line re-power on (line off a few minutes) or reset the PS_ON signal. Also please avoid over current condition over 30 seconds to avoid unit failure. In addition, the value of OCP is fixed and not adjustable.

Condition	Delay time
When over current is output (110% or more at load of forced air) +3.3V, +5V, +12V (ZWX300 : +12V-1, +12V-2)	5 seconds or more
When a value that peak output power per total output power is 110% or more.	Immediate
When output is short +3.3V, +5V +12V (only ZWX300: +12V-1, +12V-2)	Immediate

-12V and 5V SB has no delay time.
Outputs will recover automatically when the over current condition removed.
When 5V SB is shut down with over current or short, all output power will be shut down.

7 Over Temperature Protection (OTP)

The OTP function (manual reset type) is provided. When ambient or internal temperature rises abnormally, OTP function operates and output will be shut down. After shut down, remove the input and cool it down to reset OTP.

Then re-input.

It is not a function to guarantee that the power supply doesn't break down in all conditions.

8 Remote Sensing (Only +3.3V)

This function compensates voltage drop of wiring from output terminals to load terminals. Connect "+3.3V sense" terminal to "+3.3V" terminal. The total line voltage drop (+ side line and - side line) shall be less than 0.3V. In case that sensing lines are too long, it is necessary to put an electrolytic capacitor in following. If remote sensing terminals are opened, the stability and the accuracy of the output turns worse. Therefore, terminal "+3.3V sense" terminal, "+3.3V" terminal must be connected.

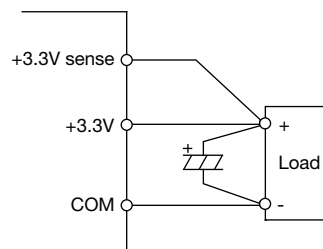

9 Output Ripple & Noise

The standard specification for maximum ripple value is measured according to measurement circuit specified by JEITA-RC9131. When load lines are longer, ripple becomes larger. In this case, electrolytic capacitor, film capacitor, etc. might be necessary to use across the load terminal. The output ripple cannot be measured accurately if the probe ground lead of oscilloscope is too long.

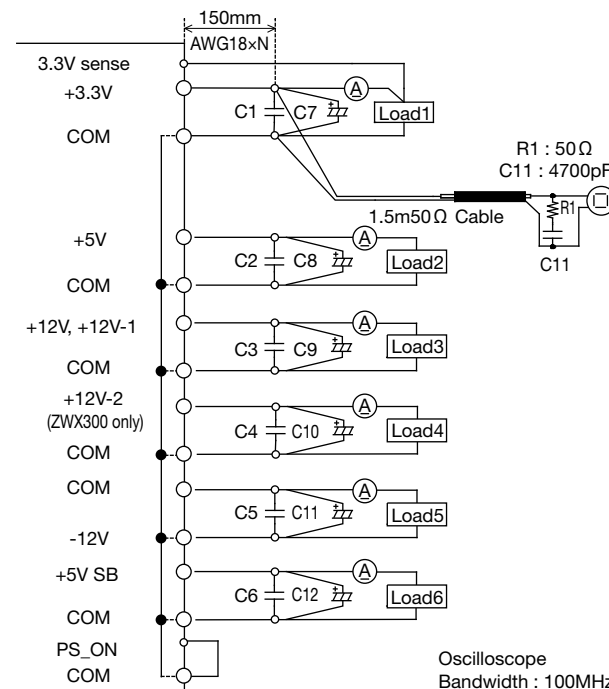

		Capacitance
C1,C2,C3,C4,C5,C6	Film Cap.	0.1uF
C7,C8,C9,C10,C11,C12	Elec. Cap.	100uF

*All COM are connected in this power supply unit

10 Peak Output Current

For ZWX series, the relation between peak output current and peak output power (Wp) must satisfy formulas below.

The mean output power during peak output (Wm) have to be less than total output power specified in the spec sheet (Wavg) in both cases for forced air cooling and convection cooling.

Also operating time at peak output current (τ) should be less than 5 sec.

(Forced air cooling : Duty ≤ 50%, convection cooling : Duty ≤ 10%)

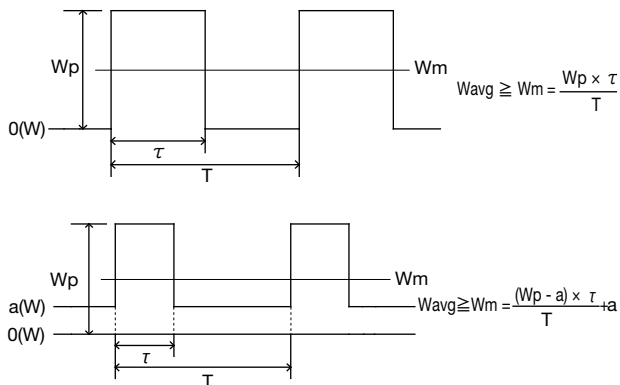

- Wp : Peak output power (W)
- Wavg : Maximum output power of specification (W)
- Wm : Average output power (W)
- τ : Pulse width of peak output power (sec)
(Operating time at peak output)
- T : Period (sec)

11 Isolation Test

Isolation resistance between output - ⊥ (protective earth) is more than 100MΩ at 500VDC. For safety operation, voltage setting of DC isolation tester must be done before the test. Ensure that the unit is fully discharged after the test.

Output - ⊥ (protective earth) : 500VDC more than 100MΩ

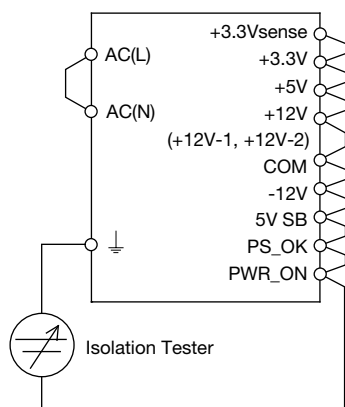

12 Withstand Voltage

This series is designed to withstand 3.0kVAC between input and output, 2.0kVAC between input and ⊥ (protective earth) and 500VAC between output and ⊥ (protective earth) each for 1 minute. When testing withstand voltage, set current limit of the withstand voltage test equipment to 20mA (output - ⊥ (protective earth): 100mA). The applied voltage must be gradually increased from zero to the testing value and then gradually decreased for shut down. When timer is used, the power supply may be damaged by high impulse voltage at timer switch on and off. Connect input and output as follows.

Input - Output : 3.0kVAC 1min (20mA)

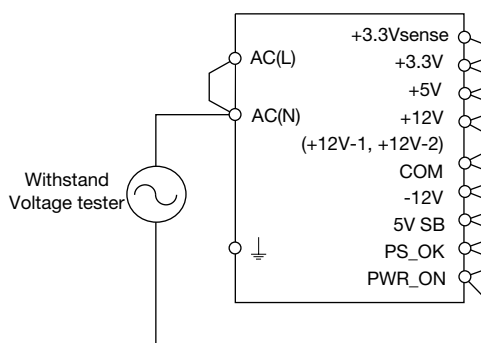

Input - ⊥ (protective earth) : 2.0kVAC 1min (20mA)

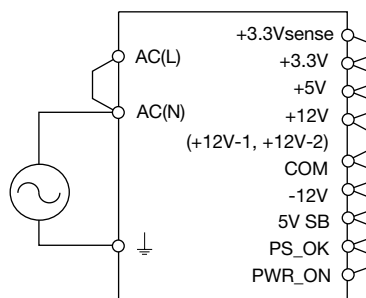

Output - ⊥ (protective earth) : 500VAC 1min (100mA)

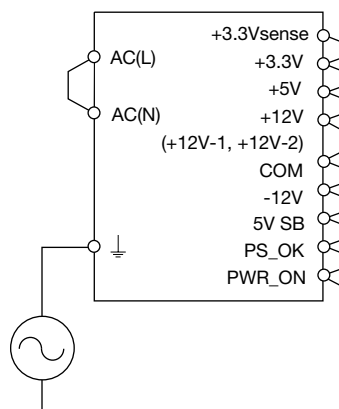

Note) This product have multilayer ceramic capacitor in secondary circuit to frame ground.

Some of the withstand voltage tester may generate high voltage at the matching with multilayer ceramic capacitor and may cause the unit damage.

So, please check the waveform of test voltage.

6. Mounting Directions

1 Output Derating According to the Mounting Directions.

Recommended standard mounting method is (A). Method (B) - (E) are also possible. Refer to the derating below. The derating values are referred to in each forced air / convection rating and forced air cooling as 100%.

ZWX180, 240, 300

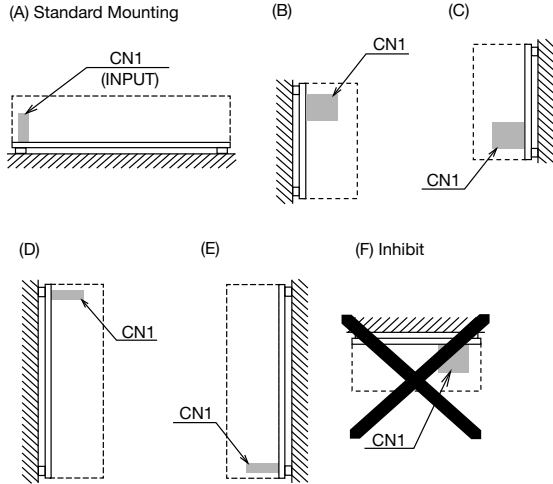

2 Output Derating

Standard type and with chassis type (/L1, /L2)

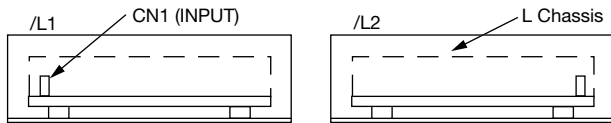

CONVECTION COOLING

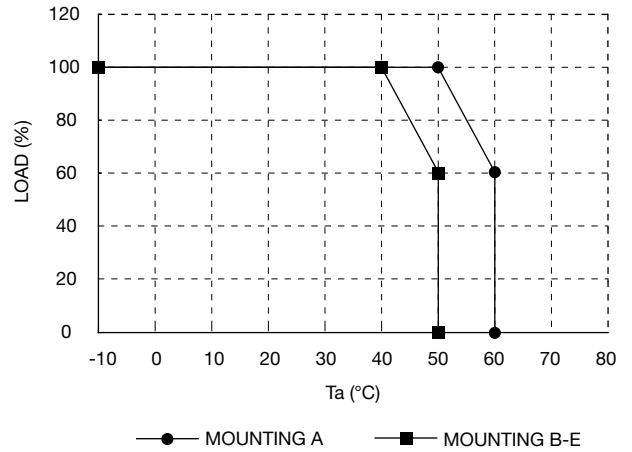

Ta (°C)	Load (%)	
	Mounting (A)	Mounting (B)-(E)
-10 to +40	100	
+50	100	60
+60	60	-

Load(%) is percent of total output power (convection). Also apply Load(%) to maximum output current (convection) and combined maximum output power (convection).

FORCED AIR COOLING

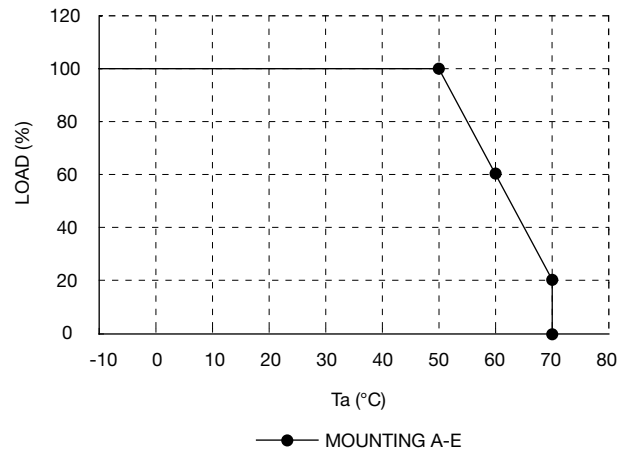

Ta (°C)	Load (%)
	Mounting (A)-(E)
-10 to +50	100
+60	60
+70	20

Load(%) is percent of total output power (forced air). Also apply Load(%) to maximum output current (forced air) and combined maximum output power (forced air).

Please make air flow to maintain core of T2 temperature 75°C and core of T3 temperature 85°C. (*1)
(Please let air (0.85m³/min (30cfm)) flow into the component side.)
Air flow should cool down all the components evenly.

With cover type (/A1, /A2)

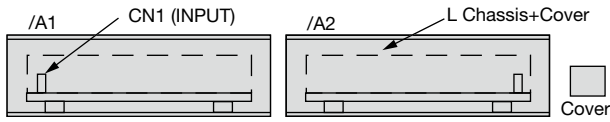

CONVECTION COOLING

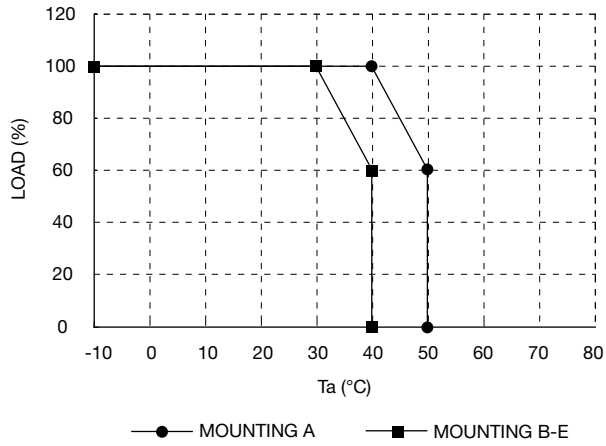

Ta (°C)	Load (%)	
	Mounting (A)	Mounting (B)-(E)
-10 to +30	100	
+40	100	60
+50	60	-

Load (%) is percent of total output power (convection). Also apply Load(%) to maximum output current (convection) and combined maximum output power (convection).

FORCED AIR COOLING

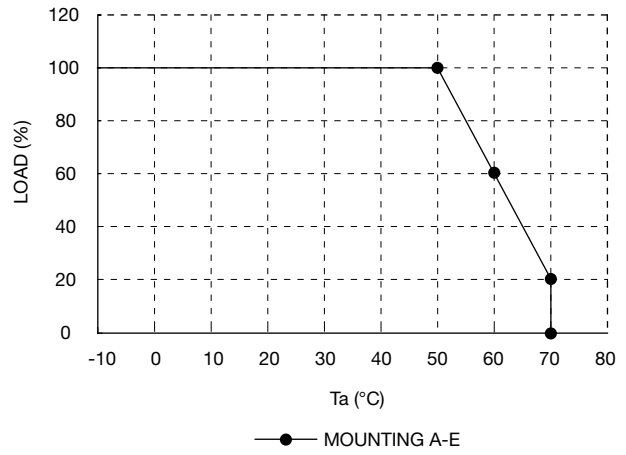

Ta (°C)	Load (%)
	Mounting (A)-(E)
-10 to +50	100
+60	60
+70	20

Load (%) is percent of total output power (forced air). Also apply Load(%) to maximum output current (forced air) and combined maximum output power (forced air).

Please make air flow to maintain core of T2 temperature 75°C and core of T3 temperature 85°C.(*1)

(Please let air (0.85m³/min (30cfm)) flow into the component side.)

Air flow should cool down all the components evenly.

(*1) T2 and T3 are shown in "2. Terminal Explanation".

3 Mounting Method

Mounting Holes size

ZWX180/240/300 : 4 holes (Φ3.5mm)

Insert the spacer (MAXΦ8.0) of height more than 8mm to lift the unit. Also use all mounting holes for the unit installation. The vibration spec is the value when the unit is mounted by 8mm spacers.

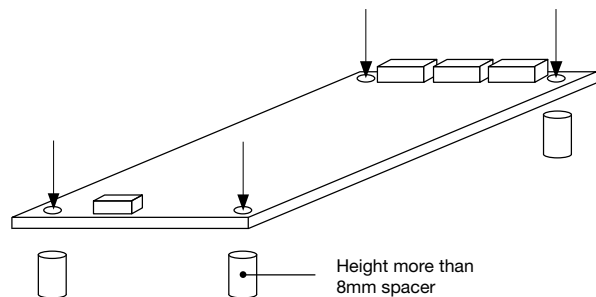

And allowable area by metal pieces is 9mm from each PCB corners. Refer to the figure below.



Condition to meet Insulation & Withstand Voltage standard.

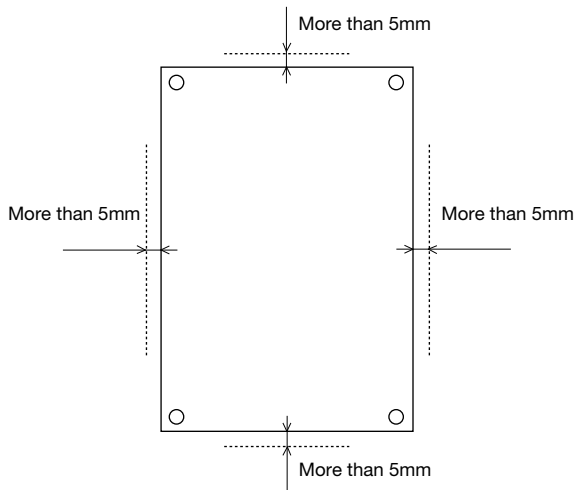
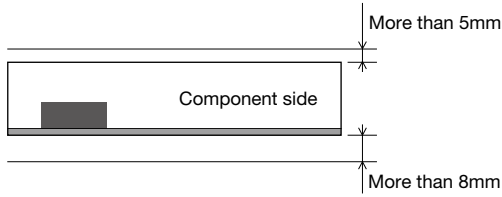

Please leave 5mm space from the surfaces and left 5mm space from the sides of PCB, especially from the solder surface, 8mm space is necessary.

If the space is not enough, the specification of insulation and withstand will not be satisfied. Please take the space in the power supply surroundings and the upper surface place of components to keep enough convection cooling.

⊥ (protective earth) should be connected to the earth terminal of the equipment. If not, the conducted noise and output noise will increase.

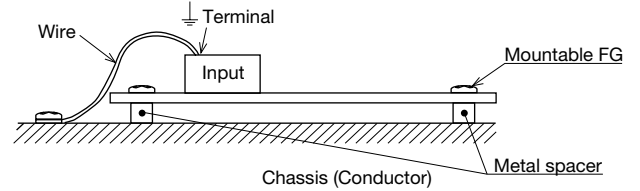

Consider the heat radiation and safety when the power supply is used in convection cooling. Please take a distance more than 15mm between the power supply and the peripheral parts. When lay out multiple units, please make sure to place 15mm or more space from each other.

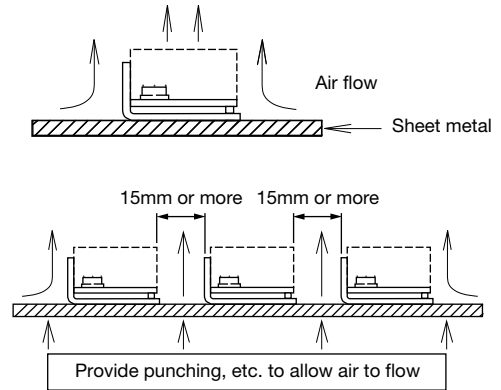

Note 1) Recommended torque for mounting screw.
M3 screw : 0.49 Nm (5kgfcm)

Note 2) Penetration depth 6mm max in the power supply.

7. Wiring Method

- (1) The output load line and input line shall be separated each other and twisted individually to improve noise sensitivity.
- (2) Noise can be reduced by attaching a capacitor to the load terminals.

- (3) For safety and EMI considerations, connect \perp terminal of input connector and mountable frame ground of ZWX series to ground terminal at equipment.

Connector manufacture method

a). Applicable wire and crimping tool

	CONNECTOR	TERMINAL PIN		CRIPPING TOOL	MANUFATURER
Input Terminal (CN1)	B3P5-VH(LF)(SN)	AWG18-22	SVH-21T-P1.1 or BVH-21T-P1.1	YC-160R	J.S.T.
Output Terminal (CN21)	5566-10A-210	AWG18-24	5556PBT, 5556PBTL	57027-5000	MOLEX
Output Terminal (CN31)	5566-22A-210	AWG18-24	5556PBT, 5556PBTL	57027-5000	MOLEX
Signal Terminal (CN41)	B2B-XH-AM(LF)(SN)	AWG22	BXH-001T-P0.6	YC-110R or YRS-110	J.S.T.
		AWG22	SXH-001T-P0.6	YC-110R or YRS-110	
Output Terminal (CN51) (ZWX300 only)	5566-04A-210	AWG18-24	5556PBT, 5556PBTL	57027-5000	MOLEX

b). Crimping Operation

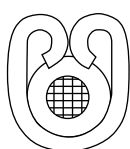

Good

Fig.1 : Examples of crimping

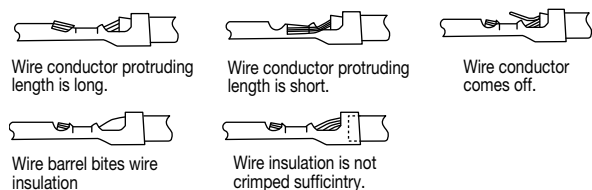

Fig.2 : Examples of defective crimping

c). Inserting contact into housing

- (1) Do not apply any pulling force to crimped part, and insert contact parallel to housing.
- (2) Insert contact into housing without stopping to innermost.
- (3) Check secure locking per each insertion by pulling wire softly in order to check that contact does not come off housing. Besides, check whether there is the backlash in the direction of insertion axis.

d). Mating and Unmating Connector

- (1) Inserting connector
Hold receptacle housing securely and insert into header straight against to header post until click sounds.
- (2) Unmating connector
Hold all wires securely and fix receptacle housing by fingers so as to pry, and then, withdraw it on the mating axis.

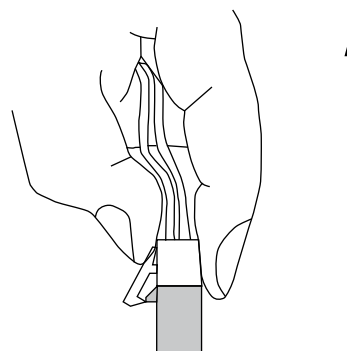

e). Routing of Wire

Routing wire so as not to apply external force to connector except force to such an extent that wire slightly buckles, considering an enough length to route and fixing of wire.

8. External Fuse Rating

Refer to the following fuse rating when selecting the external fuses that are to be used on input line. Surge current flows when line turns on. Please use slow-blow or time-lag type fuse, not fast-blow fuse. Fuse rating is specified by in-rush current value at line turn-on. Do not select the fuse according to input current (RMS.) values under the actual load condition

- ZWX180: 6.3A
- ZWX240: 8.0A
- ZWX300: 10A

9. Before concluding that the unit is at fault

- (1) Check if the rated input voltage is connected.
- (2) Check if the wiring of input and output is correct.
- (3) Check if the wire material is not too thin.
- (4) If use function of the +3.3V sense, check if the +3.3V sense connector is not opened. Control, check if the +3.3V sense connector is not opened. If in open condition, output voltage accuracy turns worse.
If use function of the PS_ON, check if the PS_ON connector is not opened. If in open condition, power supply will not output.
- (5) Is the chassis of power supply hot abnormally? The output is shut down by OTP operation.
- (6) Please re-input after the unit to cool down sufficiently. The OTP function is provided. When ambient or internal temperature rises abnormally, OTP function operates and output will be shut down. After shut down, remove the input and cool it down to reset OTP. Then re-input.
- (7) Check if the output current and output wattage dose not exceed specification.
- (8) Audible noise can be heard when input voltage waveform is not sinusoidal.
- (9) Audible noise can be heard during dynamic-load operation.

- (10) Ensure that a large capacitor is not connected on the load side.
- (11) Please use it following, the stop of the output or the unstable operation might be caused. Please use within maximum capacitance shown below.
- (12) Some consideration is necessary, if it connects over capacity of the following. Please inquire details of our company.

Maximum capacitance on each output
ZWX Series

Output voltage	capacitance (μF)
+3.3V	6,000
+5V	10,000
+12V, +12V-1	5,000
+12V-2 (only ZWX300)	3,000
-12V	350
5V SB	350

- (13) When external voltage of 3V or more is applied at the output terminals of 3.3V or 5V unit, sink current will flow when PS_ON signal is at OFF condition.
Also, there is possibility that output voltage might not turn OFF (output voltage is continuous).
In addition, customer device might be damaged due to sink current.
Therefore, avoid injecting external voltage at the output terminals.

10. Range of Free Warranty

This product is warranted for a period of 3 years from the date of shipment. As for the breakdown under a normal use during free warranty term, repair is at free of charge.

Conditions of usage at the free of charge warranty are as follows.

- (1) Average operating temperature (ambient temperature of the power supply unit) is under 40°C.
- (2) Average load factor is less than 80% of each channel.
- (3) Installation method: Standard installation.
Refer to output derating for the load factor.

Following cases are not covered by warranty.

- (1) Improper usage like dropping products, applying shock and defects from operation exceeding specification of the units.
- (2) Defects resulting from natural disaster (fire, flood).
Unauthorized modifications or repair by the buyers' defects not cause by our company.

11. Option

1 Harness for input / output

Optional harness is available with extra charge.

ZWX-HA-01
(For output)

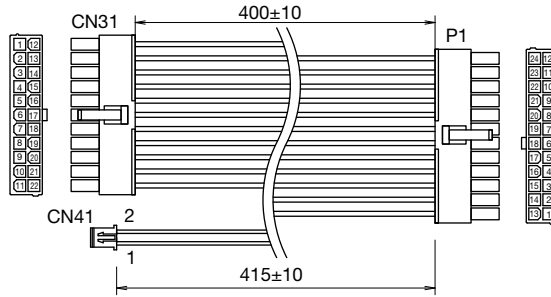

ZWX-HA-02
(For output)

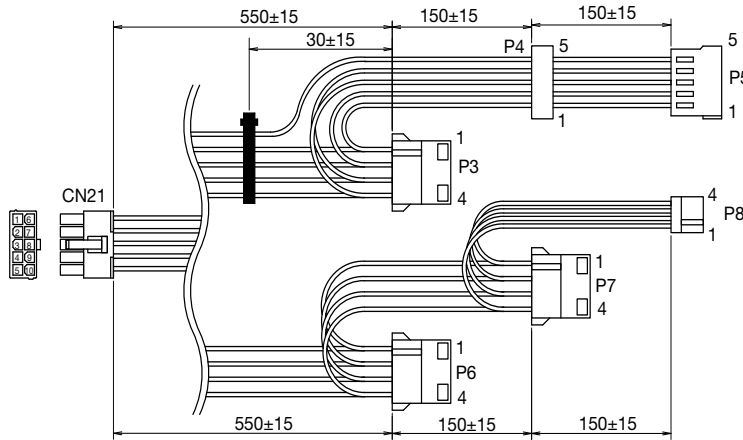

ZWX-HA-03
(For output)

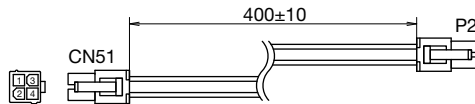

ZWX-HA-01 pin assignment for connectors

C N NAME	Pin No.	FUNCTION	WIRE		CONNECTOR TYPE
			COLOR	TYPE	
P1	1	+3.3V	ORANGE	UL1007 AWG18	HOUSING 5557-24R-210(Molex) TERMINAL 5556PBT(Molex)
	2	+3.3V	ORANGE		
	3	COM	BLACK		
	4	+5V	RED		
	5	COM	BLACK		
	6	+5V	RED		
	7	COM	BLACK		
	8	PWR_OK	GRAY	UL1007 AWG22	
	9	+5VSB	VIOLET	UL1007 AWG18	
	10	+12V	YELLOW		
	11	+12V	YELLOW		
	12	+3.3V	ORANGE	(BROWN AWG22)	
	13	+3.3V & sence	ORANGE & BROWN	UL1007 AWG20	
	14	-12V	BLUE	UL1007 AWG18	
	15	COM	BLACK	UL1007 AWG22	
	16	PS_ON	GREEN	UL1007 AWG18	
	17	COM	BLACK		
	18	COM	BLACK		
	19	COM	BLACK		
	20	NC	-		
	21	+5V	RED		
	22	+5V	RED		
	23	+5V	RED		
	24	COM	BLACK		

ZWX-HA-02 ZWX-HA-03 pin assignments for connectors

CN NAME	Pin No.	FUNCTION	WIRE		CONNECTOR TYPE
			COLOR	TYPE	
P2	1	COM	BLACK	UL1007 AWG18	HOUSING 5557-04R-210 (Molex)
	2	COM	BLACK		TERMINAL 5556PBT (Molex)
	3	+12V-2	YELLOW		
	4	+12V-2	YELLOW		
P3 P6 P7	1	+12V	YELLOW	UL1007 AWG18	HOUSING 770827-1 (AMP)
	2	COM	BLACK		TERMINAL 350557-4 (AMP)
	3	COM	BLACK		
	4	+5V	RED		
P4	1	+12V	YELLOW	UL1007 AWG18	HOUSING C194PFIA1A0 (CviLux) COVER C194PFIC010 (CviLux)
	2	COM	BLACK		
	3	+5V	RED		
	4	COM	BLACK		
	5	+3.3V	ORANGE		
P5	1	+12V	YELLOW	UL1007 AWG18	HOUSING C194PF00100 (CviLux) TERMINAL C194T03APP0 (CviLux)
	2	COM	BLACK		
	3	+5V	RED		
	4	COM	BLACK		
	5	+3.3V	ORANGE		
P8	1	+5V	RED	UL1007 AWG18	HOUSING 171822-4 (AMP) TERMINAL 170204-2 (AMP)
	2	COM	BLACK		
	3	COM	BLACK		
	4	+12V	YELLOW		

ZWX-HA-03 is for 12V-2 of ZWX300.

It is not used with ZWX180 and ZWX240.

ZWX-HA-04 (For output)

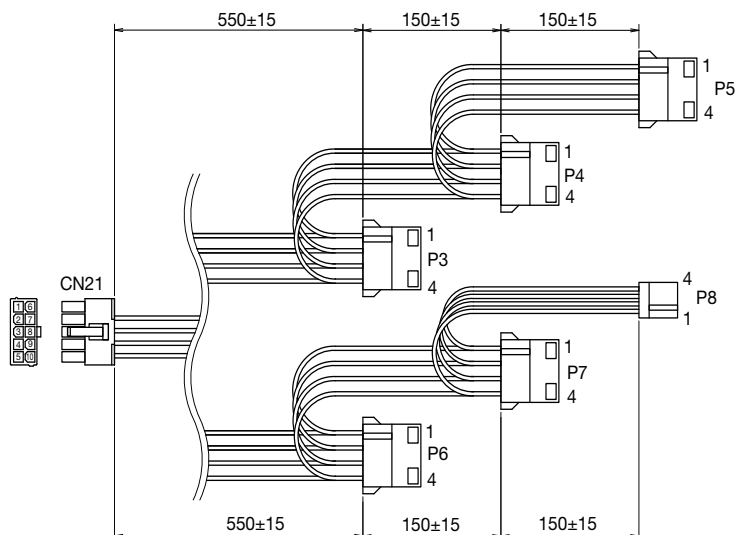

ZWX-HA-04 pin assignment for connectors

CN NAME	Pin No.	FUNCTION	WIRE		CONNECTOR TYPE
			COLOR	TYPE	
P3, P4 P5, P6, P7	1	+12V	YELLOW	UL1007 AWG18	HOUSING 770827-1 (AMP)
	2	COM	BLACK		TREMINAL 350557-4 (AMP)
	3	COM	BLACK		
	4	+5V	RED		
P8	1	+5V	RED	UL1007 AWG18	HOUSING 171822-4 (AMP)
	2	COM	BLACK		TREMINAL 170204-2 (AMP)
	3	COM	BLACK		
	4	+12V	YELLOW		

*No S-ATA connectors available on ZWX-HA-04.

Choose ZWX-HA-02 when S-ATA is required.

HA-2-IN (For input)

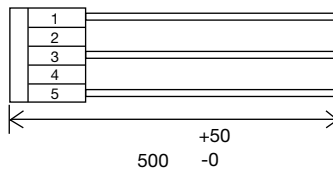

HA-2-IN pin assignment for connectors

Pin No.	WIRE		CONNECTOR TYPE
	COLOR	TYPE	
1	BLACK	UL1015 AWG18	HOUSING VHR-5N (J.S.T.)
2	N.A.		TREMINAL SVH-21T-P1.1 (J.S.T.)
3	WHITE		
4	N.A.		
5	GREEN		

Компания «Life Electronics» занимается поставками электронных компонентов импортного и отечественного производства от производителей и со складов крупных дистрибьюторов Европы, Америки и Азии.

С конца 2013 года компания активно расширяет линейку поставок компонентов по направлению коаксиальный кабель, кварцевые генераторы и конденсаторы (керамические, пленочные, электролитические), за счёт заключения дистрибьюторских договоров

Мы предлагаем:

- Конкурентоспособные цены и скидки постоянным клиентам.
- Специальные условия для постоянных клиентов.
- Подбор аналогов.
- Поставку компонентов в любых объемах, удовлетворяющих вашим потребностям.
- Приемлемые сроки поставки, возможна ускоренная поставка.
- Доставку товара в любую точку России и стран СНГ.
- Комплексную поставку.
- Работу по проектам и поставку образцов.
- Формирование склада под заказчика.
- Сертификаты соответствия на поставляемую продукцию (по желанию клиента).
- Тестирование поставляемой продукции.
- Поставку компонентов, требующих военную и космическую приемку.
- Входной контроль качества.
- Наличие сертификата ISO.

В составе нашей компании организован Конструкторский отдел, призванный помогать разработчикам, и инженерам.

Конструкторский отдел помогает осуществить:

- Регистрацию проекта у производителя компонентов.
- Техническую поддержку проекта.
- Защиту от снятия компонента с производства.
- Оценку стоимости проекта по компонентам.
- Изготовление тестовой платы монтаж и пусконаладочные работы.



Тел: +7 (812) 336 43 04 (многоканальный)

Email: org@lifeelectronics.ru