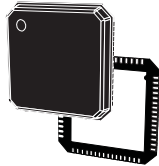

## AM/FM/HD-Radio™/DAB automotive digital output tuner

**VFQFPN64 (9 x 9 x 1.0 mm)**

### Features

- AEC-Q100 qualified 
- Full automotive grade RFCMOS design
- Quad-band:
  - AM/FM Band
  - Band-III
  - Band-L
- Software configurable digital base-band interface (I2S or JESD204B)
- Compatible with digital radio standards: DAB, DRM, and HD-Radio™
- Software programmable
- Very high dynamic range built-in  $\Sigma\Delta$  ADC
- Very low external component count (no pin diodes, transformers or varicap)
- RoHS compliant small footprint package

### Description

The **STA709** is a single chip, full CMOS, quad-band, front-end tuner specifically tailored to Software-Defined-Radio (SDR) systems.

When paired with an application processor, STA709 enables the implementation of a SDR solution to receive analog (AM/FM/WX) and digital terrestrial broadcasting standards (e.g. HD-Radio™/DAB/DRM).

The STA709 features front-end low-noise amplifiers (LNAs) covering AM band (LW/MW/SW), FM and WX bands, DAB band-III and band-L.

After on-chip IF filtering, the STA709 digitizes the signal with a high dynamic range  $\Sigma\Delta$  ADC ahead of the complex phase-quadrature base-band signal down conversion to provide a stable digital base-band output to the companion application processor.

The digital base-band signal is transmitted to the application processor via a flexible and configurable serial digital interface operating either as single-ended I2S, LVDS I2S or JESD204B.

The STA709 offers automotive grade and state-of-art RF performances with minimum external component count.

#### Product status link

[STA709](#)

#### Device summary

Order code	Package	Packing
STA709	VFQFPN64	Tray
STA709TR	(9 x 9 x 1 mm)	Tape & Reel

# 1 Block diagram

Figure 1. Block diagram

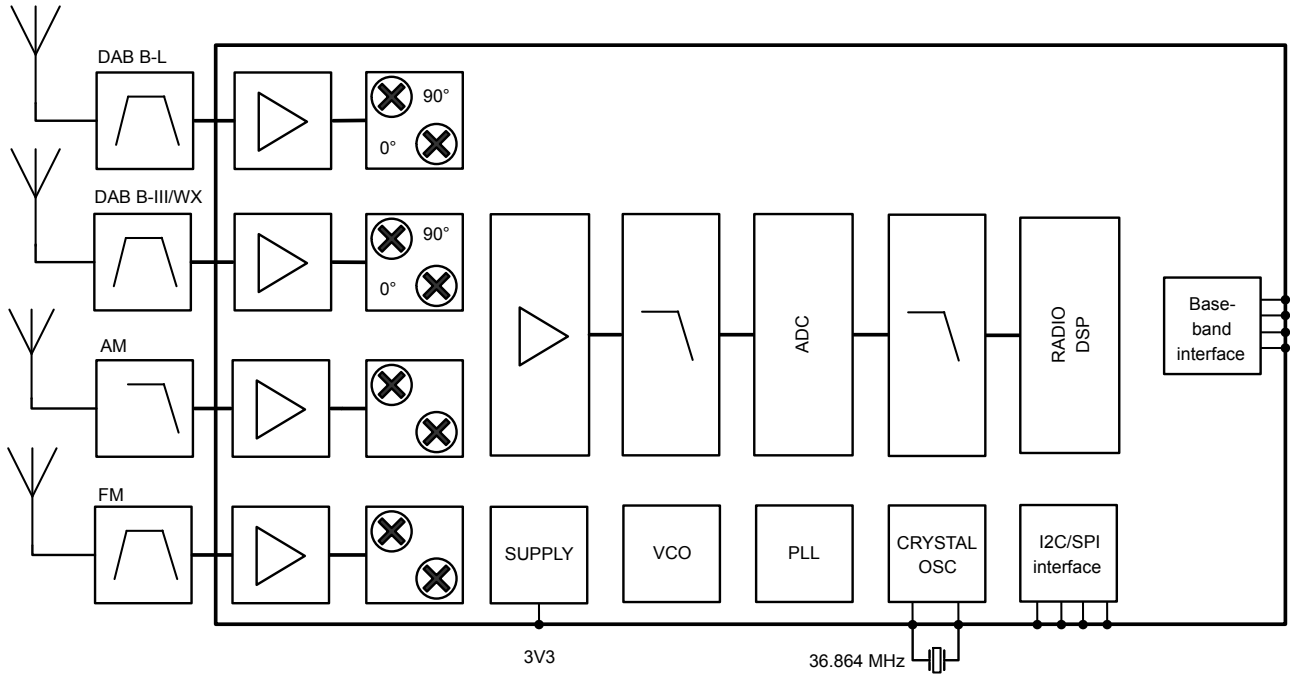

## 2 Electrical specification

### 2.1 Absolute maximum ratings

**Table 1. Absolute maximum ratings**

Symbol	Parameter	Test condition	Min	Typ	Max	Units
V <sub>CC</sub>	Abs. supply voltage	-	-0.5	-	3.6	V
T <sub>stg</sub>	Storage temperature	-	-55	-	150	°C
V <sub>ESD</sub>	ESD absolute minimum withstand voltage	Human Body model	> ±2000  <sup>(1)</sup>			V
		Charged device model	> ±500  <sup>(2)</sup>			
		Charged device model, corner pins	> ±750			
-	Max. input current at any pin (latch-up characteristic)	I <sub>INMAX</sub>	±100			mA

1. |±1000| on AM\_IN pin

2. |±400| on AM\_IN pin

### 2.2 Thermal data

**Table 2. Thermal data**

Symbol	Parameter	Test condition	Value	Units
R <sub>th j-amb</sub>	Thermal resistance junction-to-ambient	Multilayer 2s2p as per JEDEC JESD51-7	27	°C/W

### 2.3 General key parameters

**Table 3. General key parameters**

Symbol	Parameter	Test condition	Min	Typ	Max	Units
V <sub>CC</sub>	3.3 V supply voltage	-	3.15	3.3	3.45	V
I <sub>CC</sub>	Supply current	FM @108 MHz, active interfaces (10 pF load)	-	-	309	mA
T <sub>amb</sub>	Ambient temperature range	-	-40	-	85	°C
T <sub>j_oper</sub>	Operative junction temp	-	-	-	125	°C
P <sub>diss</sub>	Dissipated power	R <sub>ext</sub> = 12 Ohm	-	-	1	W

### 3 Package information

In order to meet environmental requirements, ST offers these devices in different grades of **ECOPACK** packages, depending on their level of environmental compliance. ECOPACK specifications, grade definitions and product status are available at: [www.st.com](http://www.st.com). ECOPACK is an ST trademark.

#### 3.1 VFQFPN-64 (9x9x1.0mm) package information

Figure 2. VFQFPN-64 (9x9x1.0 mm) package outline

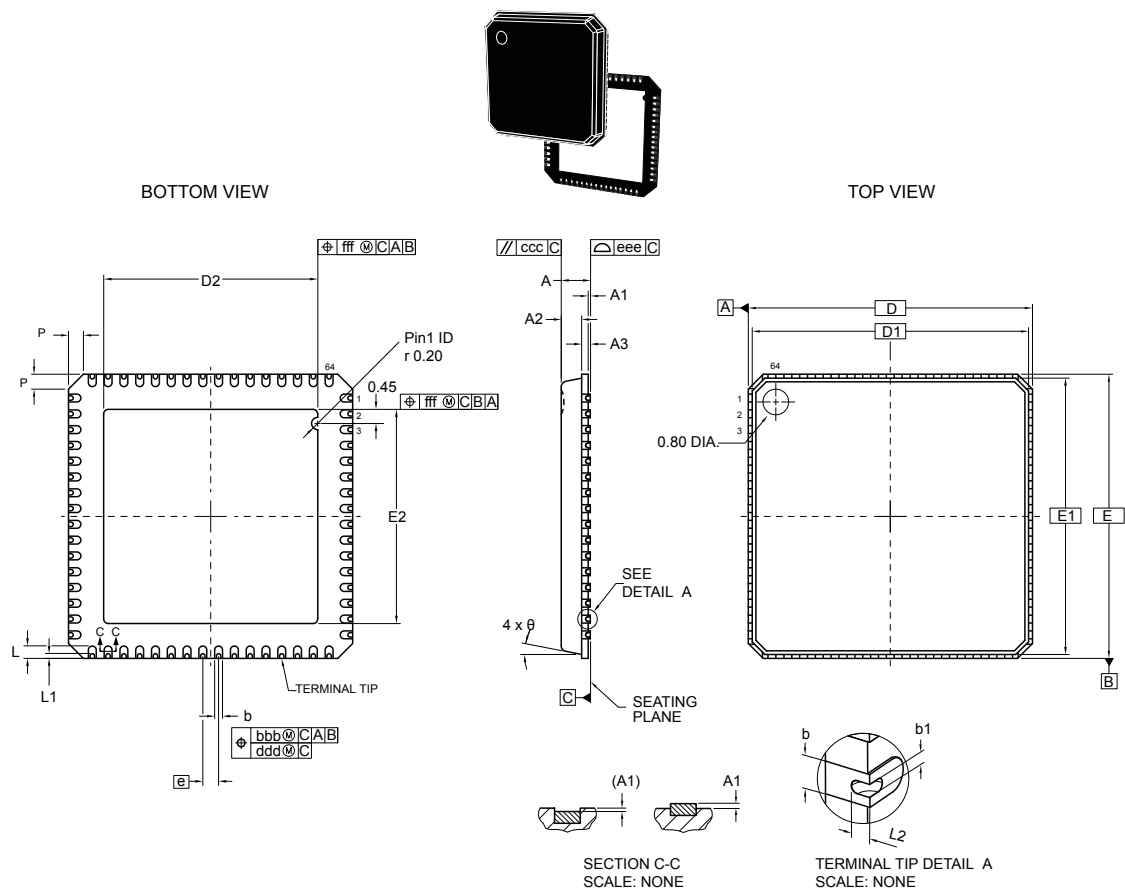

8511068\_B\_A02G

GAPGPS03460

Table 4. VFQFPN-64 (9x9x1.0 mm) package mechanical data

Ref.	Dimensions in mm		
	Min.	Typ.	Max.
$\Theta$	-	-	14
A	-	-	1.0
A1	0.00	-	0.05
A2	0.55	-	0.80
A3	0.20 REF		
b <sup>(1)</sup>	0.18	0.25	0.30

Ref.	Dimensions in mm		
	Min.	Typ.	Max.
b1	-	0.15	-
D	9.00 BSC		
D1 <sup>(2)</sup>	8.75 BSC		
D2	-	6.70	-
e	0.50 BSC		
E	9.00 BSC		
E1 <sup>(2)</sup>	8.75 BSC		
E2	-	6.70	-
L	0.30	-	0.50
L1	0.15 REF		
L2	-	0.10	-
P	-	-	0.60
<b>Tolerance of form and position</b>			
aaa	0.15		
bbb	0.10		
ccc	0.10		
ddd	0.05		
eee	0.08		
fff	0.10		

1. Maximum allowable burr is 0.076 mm in all directions.

2. D1 and E1 are Maximum plastic body size dimensions including mold mismatch. Dimensions D1 and E1 do not include mold flash or protrusions. Allowable mold flash or protrusions is "0.25 mm (0.0098 inch)" per side.

**Note:** The package is compliant to IPC/JEDEC J-STD-020D June 2007 standard Moisture/Reflow Sensitivity Classification for Nonhermetic Solid State Surface Mount Devices, MSL Level 3.

## Revision history

**Table 5. Document revision history**

Date	Revision	Changes
29-Nov-2016	1	Initial release.
25-Nov-2019	2	Updated <a href="#">Figure 1. Block diagram.</a>

**IMPORTANT NOTICE – PLEASE READ CAREFULLY**

STMicroelectronics NV and its subsidiaries (“ST”) reserve the right to make changes, corrections, enhancements, modifications, and improvements to ST products and/or to this document at any time without notice. Purchasers should obtain the latest relevant information on ST products before placing orders. ST products are sold pursuant to ST’s terms and conditions of sale in place at the time of order acknowledgement.

Purchasers are solely responsible for the choice, selection, and use of ST products and ST assumes no liability for application assistance or the design of Purchasers’ products.

No license, express or implied, to any intellectual property right is granted by ST herein.

Resale of ST products with provisions different from the information set forth herein shall void any warranty granted by ST for such product.

ST and the ST logo are trademarks of ST. For additional information about ST trademarks, please refer to [www.st.com/trademarks](http://www.st.com/trademarks). All other product or service names are the property of their respective owners.

Information in this document supersedes and replaces information previously supplied in any prior versions of this document.

© 2019 STMicroelectronics – All rights reserved

Компания «Life Electronics» занимается поставками электронных компонентов импортного и отечественного производства от производителей и со складов крупных дистрибьюторов Европы, Америки и Азии.

С конца 2013 года компания активно расширяет линейку поставок компонентов по направлению коаксиальный кабель, кварцевые генераторы и конденсаторы (керамические, пленочные, электролитические), за счёт заключения дистрибьюторских договоров

Мы предлагаем:

- Конкуренспособные цены и скидки постоянным клиентам.
- Специальные условия для постоянных клиентов.
- Подбор аналогов.
- Поставку компонентов в любых объемах, удовлетворяющих вашим потребностям.
- Приемлемые сроки поставки, возможна ускоренная поставка.
- Доставку товара в любую точку России и стран СНГ.
- Комплексную поставку.
- Работу по проектам и поставку образцов.
- Формирование склада под заказчика.
- Сертификаты соответствия на поставляемую продукцию (по желанию клиента).
- Тестирование поставляемой продукции.
- Поставку компонентов, требующих военную и космическую приемку.
- Входной контроль качества.
- Наличие сертификата ISO.

В составе нашей компании организован Конструкторский отдел, призванный помогать разработчикам, и инженерам.

Конструкторский отдел помогает осуществить:

- Регистрацию проекта у производителя компонентов.
- Техническую поддержку проекта.
- Защиту от снятия компонента с производства.
- Оценку стоимости проекта по компонентам.
- Изготовление тестовой платы монтаж и пусконаладочные работы.



Тел: +7 (812) 336 43 04 (многоканальный)

Email: [org@lifeelectronics.ru](mailto:org@lifeelectronics.ru)